

2016

---

NICHD Division of Intramural Research  
ANNUAL REPORT

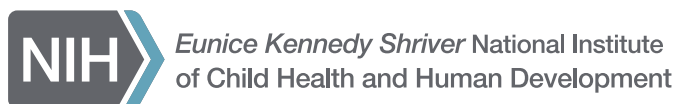

# Table of Contents

---

6	Board of Scientific Counselors
8	Scientific Director's Preface
10	Office of Education
12	Office of the Clinical Director
13	Clinical Trials
	Clinical Training Programs
16	Maternal-Fetal Medicine Fellowship Training Program
17	Medical Genetics Training Program
18	NICHD-NIDDK Interinstitute Endocrine Training Program
21	Pediatric Endocrinology Inter-Institute Training Program
24	Reproductive Endocrinology and Infertility Training Program
27	Administrative Management Branch
29	Research Animal Management Branch
	Scientific Core Facilities
31	<b>Peter Backlund:</b> Mass Spectrometry Core
36	<b>Ben Feldman:</b> Zebrafish Core
42	<b>Forbes Porter:</b> Molecular Genomics Laboratory Core
44	<b>Vincent Schram:</b> Microscopy and Imaging Core
47	<b>Dave Songco:</b> Computer Support Services Core
50	Affinity Groups

---

## B

57	<b>Tamás Balla:</b> Phosphoinositide Messengers in Cellular Signaling and Trafficking
61	<b>Anirban Banerjee:</b> Structural and Chemical Biology of Membrane Proteins
63	<b>Jeff Baron:</b> Regulation of Childhood Growth
67	<b>Peter Basser:</b> Quantitative Imaging and Tissue Sciences
77	<b>Sergey Bezrukov:</b> Biophysics of Large Membrane Channels
83	<b>Juan Bonifacino:</b> Protein Sorting in the Endosomal-Lysosomal System
88	<b>Marc Bornstein:</b> Child and Family Development Across the First Three Decades
93	<b>Andres Buonanno:</b> Neuregulin–ErbB Signaling in Neuronal Development and Psychiatric Disorders
100	<b>Harold Burgess:</b> Neuronal Circuits Controlling Behavior: Genetic Analysis in Zebrafish

---

## C

105	<b>Mike Cashel:</b> Global Regulation of Gene Expression by ppGpp
109	<b>Leonid Chernomordik:</b> Variability Between the Degrees of Maturation in Individual Dengue Virions
112	<b>Ajay Chitnis:</b> Building the Zebrafish Lateral Line System
117	<b>Janice Chou:</b> Molecular Genetics of Heritable Human Disorders
122	<b>David Clark:</b> Chromatin Remodeling and Gene Activation
127	<b>Bob Crouch:</b> Physiological, Biochemical, and Molecular-Genetic Events Governing the Recognition and Resolution of RNA/DNA Hybrids

---

**D**

- 132 **Mary Dasso:** Chromosome Segregation in Higher Eukaryotes  
139 **Igor Dawid:** Molecular Genetics of Embryogenesis in Zebrafish and *Xenopus*  
146 **Angela Delaney:** Regulation of Pubertal Onset and Reproductive Development  
150 **Melvin DePamphilis:** Regulation of Mammalian Cell Proliferation and Differentiation  
157 **Tom Dever:** Mechanism and Regulation of Eukaryotic Protein Synthesis  
162 **Maria Dufau Catt:** Receptors and Actions of Peptide Hormones and Regulatory  
Proteins in Endocrine Mechanisms

---

**F**

- 167 **Douglas Fields:** Nervous System Development and Plasticity

---

**G**

- 173 **Amir Gandjbakhche:** Quantitative Biophotonics for Tissue Characterization and Function

---

**H**

- 182 **Alan Hinnebusch:** Transcriptional and Translational Regulatory Mechanisms in  
Nutrient Control of Gene Expression  
187 **Dax Hoffman:** Molecular Nature and Functional Role of Dendritic Voltage-Gated Ion  
Channels

---

**K**

- 192 **Stephen Kaler:** Mechanisms of and Rational Remedies for Inherited Neurometabolic  
Disorders  
198 **Judy Kassiss:** Control of Gene Expression during Development  
205 **Jim Kennison:** Genomics of Development in *Drosophila*

---

**L**

- 211 **Chi-Hon Lee:** Assembly and Function of *Drosophila* Chromatic Circuits  
217 **Sergey Leikin:** Extracellular Matrix Disorders: Molecular Mechanisms and Treatment  
Targets  
224 **Henry Levin:** The Biological Impact and Function of Transposable Elements  
231 **Mary Lilly:** Cell Cycle Regulation in Oogenesis  
237 **Jennifer Lippincott-Schwartz:** Interplay between Membrane Organelles, Cytoskeleton,  
and Metabolism in Cell Organization and Function  
241 **Y. Peng Loh:** Neurosecretory Proteins in Neuroprotection, Neurodevelopment, and  
Cancer  
248 **Jon Lorsch:** The Molecular Mechanics of Eukaryotic Translation Initiation  
251 **Paul Love:** Genes and Signals Regulating Mammalian Hematopoiesis

---

## M

- 258 **Todd Macfarlan:** Evolving Mechanisms of Transcriptional Control in Mammals  
262 **Matthias Machner:** Host-pathogen interactions during *Legionella pneumophila* infection  
266 **Richard Maraia:** RNA Metabolism in Cell Biology, Growth, and Development  
272 **Leonid Margolis:** Pathogenesis of HIV-1 and its Copathogens in Human Tissues  
277 **Joan Marini:** Genetic Disorders of Bone and Extracellular Matrix  
284 **Chris McBain:** Hippocampal Interneurons and Their Role in the Control of Network  
Excitability  
287 **Anil Mukherjee:** Childhood Neurodegenerative Lysosomal Storage Disorders

---

## O

- 293 **Ida Owens:** Molecular Biology, Regulation, and Biochemistry of UDP-  
Glucuronosyltransferase Isozymes  
299 **Keiko Ozato Dawid:** Gene Regulation in Innate Immunity

---

## P

- 305 **Karel Pacak:** Diagnosis, Localization, Pathophysiology, and Molecular Biology of  
Pheochromocytoma and Paraganglioma  
312 **Karl Pfeifer:** Molecular Genetics of an Imprinted Gene Cluster on Mouse Distal  
Chromosome 7  
320 **Forbes Porter:** Cholesterol Homeostasis and Genetic Syndromes

---

## R

- 326 **Roberto Romero:** Mechanisms of Disease in Preterm Labor and Complications of  
Prematurity; Prenatal Diagnosis of Congenital Anomalies  
332 **Tracey Rouault:** Regulation of Mammalian Intracellular Iron Metabolism and  
Biogenesis of Iron Sulfur Proteins

---

## S

- 337 **Tom Sargent:** Control of Ectodermal Development in Vertebrate Embryos  
340 **Mihaela Serpe:** Mechanisms of Synapse Assembly, Maturation, and Growth during  
Development  
345 **Yun-Bo Shi:** Thyroid Hormone Regulation of Vertebrate Postembryonic Development  
350 **Alexander Sodt:** Modeling the Biophysics of the Membrane  
353 **Stanko Stojilkovic:** Signaling and Secretion in Neuroendocrine Cells  
358 **Mark Stopfer:** Olfactory Coding and Decoding by Ensembles of Neurons  
362 **Gisela Storz:** Regulatory Small RNAs and Small Proteins  
366 **Constantine Stratakis:** Molecular Genetics of Endocrine Tumors and Related Disorders  
374 **Stephen Suomi:** Genetic and Environmental Determinants of Primate Biobehavioral  
Development

---

**W**

- 380 **Brant Weinstein:** Development of the Vertebrate Circulatory System  
385 **Roger Woodgate:** Studies on DNA Replication, Repair, and Mutagenesis in Eukaryotic  
and Prokaryotic Cells

---

**Y**

- 388 **Jack Yanovski:** Physiology, Psychology, and Genetics of Obesity

---

**Z**

- 396 **Joshua Zimmerberg:** The Regulation or Disturbance of Protein/Lipid Interactions in  
Influenza, Malaria, Diabetes, Muscular Dystrophy, Brain Trauma, and Obesity

- 402 Colophon

# Board of Scientific Counselors

---

\* *nominee*

**Scott A. Rivkees, MD, Chair**

7/1/15 – 6/30/20  
Pediatric Endocrinology

Professor, Nemours Eminent Scholar and Chair  
Department of Pediatrics  
University of Florida  
Physician in Chief  
Shands Hospital for Children

**Kate G. Ackerman, MD\***

7/1/16 – 6/30/21  
Developmental Biology, Genetics,  
& Pediatrics

Associate Professor  
Departments of Pediatrics and Biomedical Genetics  
University of Rochester Medical Center  
School of Medicine and Dentistry

**Rita J. Balice-Gordon, PhD**

7/1/13 – 6/30/18  
Neuroscience

Head, Neuroscience Research  
Sanofi, Inc.

**Jeanne Brooks-Gunn, PhD**

7/1/13 – 6/30/18  
Developmental Psychology &  
Behavioral Science

Virginia and Leonard Marx Professor of Child Development  
Teachers College and College of Physicians and Surgeons  
Columbia University

**Serdar E. Bulun, MD\***

7/1/16 – 6/30/21  
Obstetrics & Gynecology

John J. Sciarra Professor and Chair  
Department of Obstetrics and Gynecology  
Northwestern University Feinberg School of Medicine  
Chief, Division of Obstetrics and Gynecology-Reproductive  
Biology Research  
Prentice Women's Hospital

**Frances E. Jensen, MD\***

7/1/15 – 6/30/20  
Neuroscience

Professor and Chair  
Neurology Department  
Perelman School of Medicine  
University of Pennsylvania

**Kojo A. Mensa-Wilmot, PhD\***

7/1/16 – 6/30/21  
Cellular Biology

Professor and Head  
Department of Cellular Biology  
University of Georgia

**Antonios G. Mikos, PhD**

7/1/13 – 6/30/18

Bioengineering & Biophysics

Louis Calder Professor of Bioengineering, Chemical & Biomolecular Engineering  
Director, Center for Excellence in Tissue Engineering  
Director, J.W. Cox Laboratory for Biomedical Engineering  
Rice University

**Yoel Sadovsky, MD**

7/1/14 – 6/30/19

Reproductive Biology, Obstetrics,  
& Gynecology

Director, Magee-Womens Research Institute  
Elsie Hilliard Chair of Women's Health  
Professor of Obstetrics, Gynecology and Reproductive Sciences  
and Microbiology and Molecular Genetics  
University of Pittsburgh School of Medicine

**Lilianna Solnica-Krezel, PhD**

7/1/12 – 6/30/17

Developmental Biology

Professor and Head  
Department of Developmental Biology  
Washington University School of Medicine

**Susan S. Taylor, PhD**

7/1/14 – 6/30/19

Structural Biology & Molecular  
Biochemistry

Professor of Chemistry and Biochemistry  
Professor of Pharmacology  
University of California, San Diego

**Eric Vilain, MD, PhD\***

7/1/15 – 6/30/20

Molecular & Human Genetics

Professor  
Departments of Human Genetics, Pediatrics, & Urology  
Chief, Division of Medical Genetics  
Department of Pediatrics  
University of California, Los Angeles

**Michelle A. Williams, ScD**

7/1/11 – 6/30/17

Epidemiology

Dean of Faculty  
Harvard T.H. Chan School of Public Health

## Message from the Scientific Director

Our 2016 annual report of the Division of Intramural Research (DIR) for the Eunice Kennedy Shriver National Institute of Child Health and Human Development is now available to you electronically, either on the web, your cell phones, or your tablets, at: <http://annualreport.nichd.nih.gov>

We invite you to look through the report site, to review our medical and scientific discoveries of the past year, to see what work a colleague may currently be engaged in, or to identify a laboratory with which you may wish to collaborate or to which to refer a student. For potential postdoctoral fellows, graduate students, and clinical fellows, the report is fully searchable. It offers you an introduction to a panoply of research endeavors in NICHD's DIR.

NICHD intramural investigators comprise a broad array of basic, translational, and clinical researchers. Our work is reflected in our mission statement:

“To plan and conduct the Institute's laboratory and clinical research programs to seek fundamental knowledge about the nature and behavior of living systems through basic, clinical, and population-based research and determine how to apply such knowledge to illuminate developmental origins of health and disease and help ensure that women and men have good reproductive health, that children are born healthy, and that people develop to live healthy and productive lives.”

We use a range of model systems in the areas of developmental biology, molecular and cellular biology, neurosciences, structural biology, imaging, behavior, and biophysics. Investigators take advantage of our resources in a 19,000-tank zebrafish core facility and work with several other animal models, from fruit flies to rats and mice, and are supported by a wide array of core services, including imaging, proteomics, and molecular genomics. Each investigator participates in at least one, and typically more, affinity groups, which are team-based and future-oriented—to build on thematic interests while responding to rapidly shifting scientific priorities as new knowledge is uncovered.

I invite you to read through the selection of our Clinical Research Protocols listed in this report (under the above-mentioned URL) and to consider how we may collaborate, through the NIH U01 grant mechanism at the NIH Clinical Research Center (<http://clinicalcenter.nih.gov/translational-research-resources/U01>). If we combine expertise, whether on rare disorders or the most persistent problems affecting



**Constantine Stratakis, MD,  
D(med)Sci, Scientific Director**

*Brenda R. Hanning, Deputy  
Director, Liaison and Training*

*Jeanne Jones, Scientific Program  
Analyst*

*Sara K. King, Scientific Program  
Analyst – Board of Scientific  
Counselors*

*Jessica Rigby, Administrative  
Support Specialist*



human health, and take advantage of our NIH infrastructure and our patient population, the support of this program can lead to our next new success in therapeutics, and/or the next miracle drug.

The DIR researchers whose names appear in this publication are committed to training the next generation of scientists and physician scientists; they include tenure-track investigators who have recently joined us and accomplished investigators who continue to forge new scientific paths. Link to their reports on the web to learn about their work in 2016. I also invite you to reach out to me, at [stratak@mail.nih.gov](mailto:stratak@mail.nih.gov), with your ideas and proposals for collaborative initiatives that we may undertake together.

Our drive and purpose, on behalf of the American public and the international community, is to strive to uncover fundamental answers to questions underlying our existence, whether they be in the basic science that underpins life or in the complexities of human health and disease. This is the privilege of and responsibility to our chosen professions.

Sincerely yours,

A handwritten signature in black ink, appearing to read 'C. Stratakis', with a large, stylized initial 'C'.

*Constantine A. Stratakis, MD, D(med)Sci  
Scientific Director, NICHD, NIH*

## Office of Education

---

The Office of Education, DIR, NICHD, was established in 2004 to support the needs of intramural trainees at all levels. We offer academic support programs, career guidance, and individualized opportunities to a population of on average 300 trainees, including postdoctoral, visiting, and research fellows; clinical fellows and medical students; graduate students; and postbaccalaureate fellows.

### Goals and Objectives

To support the training needs of intramural scientists, fellows, and students at all levels is the goal of the Office of Education. This is achieved through recruitment and development of academic support programs; support of accreditation; contributions to mentoring, evaluation, and career guidance; and creation of new training initiatives. Additional areas of involvement include career development programming, networking among fellows and alumni, grantsmanship, and the enhancement of fellows' competitiveness for awards, as well as support of new tenure-track investigators.

### Notable accomplishments of the past year

In the spring of 2016, the Division of Intramural Research gave its ninth Mentor of the Year awards to staff scientist Julian Lui and postdoctoral fellow Shlomo Krispin. Twenty NICHD fellows were recipients of the 2017 FARE (Fellows Award for Research Excellence) awards. The NICHD Developing Talent program, established in 2011, added two new postbaccalaureate scholars, Amber Simmons (lab of Peter Basser) and Oluwadamilola Bankole (lab of Henry Levin), while Nicolas Johnson (lab of Mary Lilly) and Rim Mehari (lab of Jack Yanovski) continued for a second year. Our professional development workshops focused on various topics, including grantsmanship, public speaking, job interviewing, networking, and scientific writing and publishing. We offered a three-week training course for college teaching and curriculum development associated with University of Maryland. Postdoctoral fellows were also given the opportunity to organize and teach our annual "Becoming an Effective Scientist" course, which entered its eleventh year, for postbaccalaureate trainees. The Office of Education is committed and actively involved in graduate and professional school advising and career counseling for our fellows. The 12<sup>th</sup> annual meeting of fellows took place at the Smithsonian Museum of the American Indian and featured keynote speakers Eric Betzig, 2014 Nobel Laureate in Chemistry, and Jorge Cham, *PHD Comics* Creator. Each spring, this retreat includes presentations by fellows and a poster presentation by each attendee and is held for about 100 people to address scientific developments



**Brenda Hanning**, *Director, Office of Education*

**Yvette R. Pittman, PhD**, *Associate Director*

**Carol Carnahan**, *Program Coordinator*

and careers. The program is developed and run by a fellows' steering committee. For our annual three-minute talk (TmT) training and awards program, we once again partnered with NHGRI and NIDCR; TmT emphasizes the importance to scientists of communicating their research and its significance to improving human health. TmT participants completed several oral presentation workshops, received one-on-one professional coaching, and were judged by internal and external panels. Alex Szatmary (lab of Ralph Nossal) won third place, and some of the finalists' video clips were presented to the NICHD's advisory council. The Office of Education continued our Graduate Student Talks initiative, established in 2014; it provides the Institute's graduate students with experience in presenting their thesis research to a non-specialist scientific audience. We established a new research ethics training plan for intramural fellows, providing eight hours of training within a fellow's initial two years, in fulfillment of Responsible Conduct of Research requirements. Along with continuing scientific orientations for all fellows, the online Annual Progress Report system was launched and is actively being used by our fellows and investigators to ensure that training goals are being met while at NICHD. The Fellows Intramural Grant Supplement (FIGS) continues to recognize our grant applicants and awardees with stipend increases. The Fellows Recruitment Incentive Award, launched in 2013, promotes the recruitment of postdoctoral fellows from backgrounds underrepresented in science. This year, the award was given to Sergey Leikin, who recruited Anna Roberts-Pilgrim. *The NICHD Connection*, a monthly newsletter run and written by fellows, will publish its 79<sup>th</sup> issue in December 2016; it continues to focus on mentoring, careers in science, and our academic programs.

## Contact

For further information, contact [pittmanyv@mail.nih.gov](mailto:pittmanyv@mail.nih.gov) or [hanningb@mail.nih.gov](mailto:hanningb@mail.nih.gov).

## Office of the Clinical Director

---

The NICHD intramural clinical research program currently includes 85 protocols with five main areas of focus: (1) adult, pediatric, and reproductive endocrinology; (2) human genetics; (3) normal growth and development; (4) national/international public health; and (5) women's health. The protocols are conducted by 36 NICHD principal investigators and 122 NICHD associate investigators. The NICHD clinical protocol portfolio spans the spectrum from Natural History to therapeutic trials. Eleven protocols involve an investigational drug or device. Four protocols support our teaching mission. Approximately half the protocols include pediatric patients.

The conduct of studies is guided by two entities administered by the Office of the Clinical Director: the NICHD Institutional Review Board (IRB) and the NICHD Data Safety Monitoring Committee (DSMC). The NICHD IRB is chaired by Karim Calis, PharmD, MPH, and has 12 members and three alternates. This past year was notable for transition of the chair position from Dr. Gilman Grave after 28 years of service to NICHD. The composition of the NICHD IRB is diverse, both in terms of medical and ethical expertise and affiliation. The IRB has specific expertise in reproductive endocrinology, gynecology, pediatrics, endocrinology, genetics, and the ethics of human subject research. NICHD's IRB is a resource for other institutes that have protocols involving children or women's health and it supports the National Children's Study. The NICHD DSMC is chaired by Frank Pucino, PharmD, and has six other members. Both committees possess expertise in issues related to clinical trials, ethics, pediatrics, genetics, and reproductive medicine.

### Contact

For more information, email [fdporter@helix.nih.gov](mailto:fdporter@helix.nih.gov) or visit <http://science.nichd.nih.gov/confluence/display/ocd/Home>.



**Forbes D. Porter, MD, PhD,**  
*Clinical Director*

Meg Keil, PhD, *Associate Director,  
Nursing and Protocol Navigation*

Maryellen Rechen, BS, RN, *Special  
Assistant to the Clinical Director*

Donna Peterson, BS, RN, *Protocol  
and Institutional Review Board  
(IRB) Coordinator*

Simona Bianconi, MD, *Staff  
Clinician*

Jenny Blau, MD, *Staff Clinician*

Andrew Demidowich, MD, *Staff  
Clinician*

Karen Adams, CRNP, *Nurse  
Practitioner*

Sheila Brady, CRNP, *Nurse  
Practitioner*

Lee Ann Keener, RN, *Research  
Nurse*

Margarita Raygada, PhD, *Genetic  
Counselor*

Craig Abbott, PhD, *Statistician*

Denise Phillips, *Clinical Research  
Coordinator*

DuShon Hutchinson, *Patient Care  
Coordinator*

Fathy Majadly, BS, *Patient  
Specimen Coordinator*

Loc Trinh, *Research Chemical  
Engineer*

## Clinical Trials at NICHD

---

Numerous clinical protocols are run by the NICHD, Division of Intramural Research (for a complete listing, please visit <https://www.clinicaltrials.gov> or <https://dir.nichd.nih.gov/dirweb/clinicaltrials.html>). The following is a list of investigators within the DIR who recruit patients, and their contact information. For detailed information on all related research projects, please check the individual investigator's listing in the report or the DIR website at <http://dir.nichd.nih.gov>.

### Behavioral Determinants and Developmental Imaging

- » Studies with healthy subjects to test and calibrate non-invasive optical imaging technology for functional brain imaging. The study is important to investigate the NIRS imaging system to explore techniques that will potentially improve the feasibility and reliability of the system according to the needs of the population whom existing imaging systems are unsuitable for. Functional near infrared spectroscopy (fNIRS) is an emerging non-invasive imaging technique to assess brain function. fNIRS measurements are based on the local changes in cerebral hemodynamic levels (oxy-hemoglobin and deoxy-hemoglobin) associated with brain activity. Due to neuro-vascular coupling, local changes in oxyhemoglobin and deoxyhemoglobin levels can serve as an indirect measure of brain activity. To probe changes in Oxy- and Deoxy-hemoglobin concentrations in the cortex that are caused by brain activity, different tasks such as the n-back test will be administered to quantify spatial and temporal brain activity. Subjects may be referred to **DR. AMIR GANDJBAKHCHÉ** at [amir@helix.nih.gov](mailto:amir@helix.nih.gov).
- » Studies on the processes by which the risk for psychopathology is transmitted from clinically depressed mothers to their children, over time and across several domains of child development, and how this risk can be modified by various contextual factors. The depressed group comprises mothers with major depression, minor depression, and dysthymia at 5 months postpartum. Contact **DR. MARC BORNSTEIN** at [marc\\_h\\_bornstein@nih.gov](mailto:marc_h_bornstein@nih.gov).

### Bone and Matrix Biology in Development and Disease

- » Studies on children with osteogenesis imperfecta, both dominant and recessive forms. Current protocols focus on natural history of secondary features of OI in pulmonary function, audiology, and neurology as well as on identification of causative genetic mutations. Patients may be referred to **DR. JOAN MARINI** at [oidoc@helix.nih.gov](mailto:oidoc@helix.nih.gov).
- » Screening and diagnosis on patients with suspected connective tissue disorders. Patients and their families receive comprehensive evaluations, counseling, and risk assessment. Patients may be referred to **DR. JOAN MARINI** at [oidoc@helix.nih.gov](mailto:oidoc@helix.nih.gov).

### Developmental Endocrine Oncology and Genetics

- » Patient-oriented research into the etiology, pathophysiology, genetics, diagnosis, localization, and treatment of pheochromocytoma (PHEO) and paraganglioma (PGL). Patients may be referred to **DR. KAREL PACAK** at [karel@mail.nih.gov](mailto:karel@mail.nih.gov).
- » Investigations on endocrine complications faced by pediatric cancer survivors. Additional studies to improve clinical care for pediatric patients with many types of endocrine cancers including

pheochromocytoma, Cushing disease, and thyroid cancer. Patients may be referred to **DR. MAYA LODISH** at [lodishma@mail.nih.gov](mailto:lodishma@mail.nih.gov).

- » Research on endocrine, genetic, and other pediatric disorders that are associated with the predisposition to endocrine and other tumors, abnormal development in fetal or later life and may affect the pituitary, the adrenal and other related organs. Patients may be referred to **DR. CONSTANTINE STRATAKIS** at [stratak@mail.nih.gov](mailto:stratak@mail.nih.gov) or to **MS. ELENA BELYAVSKAYA** at 301-496-0862.
- » Counseling and research on patients with suspected or diagnosed genetic disorders. Patients and their families receive comprehensive evaluations, counseling, and risk assessment. Patients may be referred to **DR. MARGARITA RAYGADA** at [raygadam@mail.nih.gov](mailto:raygadam@mail.nih.gov) or call 301-451-8822.

## Integrative Molecular, Membrane, Cell, and Tissue Pathophysiology

- » Studies on patients with genetic disorders related to fragile sarcolemma muscular dystrophy. This includes Limb-Girdle Muscular Dystrophy type (LGMD) 2B-F, I, L, Myoshi Myopathy (MM), Becker Muscular Dystrophy (BMD), Myoshi Muscular Dystrophy -3 (MMD3). Patients may be referred to **DR. JOSHUA ZIMMERBERG** at [zimmerbj@mail.nih.gov](mailto:zimmerbj@mail.nih.gov) or **MS. HANG WATERS** at [watershn@mail.nih.gov](mailto:watershn@mail.nih.gov).

## Metal Biology and Molecular Medicine

- » Studies on patients with genetic disorders related to altered copper transport. This includes patients with Menkes disease, MEDNIK syndrome, Huppke-Brendel syndrome, ATP7A-related distal motor neuropathy, and Wilson disease. Patients may be referred to **DR. STEPHEN KALER** at [kalers@mail.nih.gov](mailto:kalers@mail.nih.gov) or **MS. MARYELLEN RECHEN** at [rechenma@mail.nih.gov](mailto:rechenma@mail.nih.gov).
- » Studies on patients with genetic disorders related to lysosomal storage. This includes patients with Alpha-mannosidosis and Mucopolysaccharidosis type 3B (Sanfillipo B). Patients may be referred to **DR. STEPHEN KALER** at [kalers@mail.nih.gov](mailto:kalers@mail.nih.gov) or **MS. KRISTEN STEVENS** at [kristen.stevens@nih.gov](mailto:kristen.stevens@nih.gov).

## Pediatric Endocrinology and Obesity

- » Studies on endocrine, genetic, and other pediatric disorders that are associated with the predisposition to develop obesity and diabetes. Patients may be referred to **DR. JACK YANOVSKI** at [yanovskj@mail.nih.gov](mailto:yanovskj@mail.nih.gov) or 301-496-4168.
- » Evaluation of patients with endocrine disorders that are associated with excess androgen, including different forms of congenital adrenal hyperplasia. Patients may be referred to **DR. DEBORAH MERKE** at [dmerke@nih.gov](mailto:dmerke@nih.gov) or **MS. TERRI MCHUGH** at 301-451-0399.
- » Clinical and genetic studies of patients with disorders of puberty and reproduction, including early and late entry into puberty, and amenorrhea or infertility due to central hypogonadism, including isolated GnRH deficiency. Patients may be referred to **DR. ANGELA DELANEY** at [delaneya@mail.nih.gov](mailto:delaneya@mail.nih.gov).
- » Studies on patients with genetic disorders related to altered cholesterol metabolism. This includes patients with Smith-Lemli-Opitz syndrome (SLOS) and Niemann-Pick Disease, type C (NPC). Patients may be referred to **DR. FORBES PORTER** at [fdporter@mail.nih.gov](mailto:fdporter@mail.nih.gov) or **MS. NICOLE FARHAT** at 301-594-1765.
- » Studies to identify novel genetic causes of idiopathic growth disorders using exome sequencing. Subjects will include children and adults with either short stature or tall stature and a pedigree that strongly suggests a monogenic inheritance. The growth disorder can be proportionate or disproportionate,

syndromic or nonsyndromic, and prenatal or postnatal in onset. Patients may be referred to DR. JEFFREY BARON at [baronj@cc1.nichd.nih.gov](mailto:baronj@cc1.nichd.nih.gov) or DR. YOUNG HEE JEE at [jeeyh@mail.nih.gov](mailto:jeeyh@mail.nih.gov).

## Perinatal and Obstetrical Research

- » ***Normal and Abnormal Fetal Anatomy using Three- and Four-Dimensional Ultrasound and Magnetic Resonance Imaging:*** In this study, we use state-of-the-art sonographic and MRI sequencing techniques to evaluate normal anatomy and function of the human fetus, cardiovascular system, neuroconnectivity, and placental hemodynamics. Imaging of the fetus and intrauterine environment is a powerful tool to assess fetal anatomy, growth, pathology, cardiovascular disorders, and neuropathology, and remains the essential tool to evaluate whether a fetus has a congenital anomaly. For more information on the study, please contact DR. ROBERTO ROMERO at [romeror@mail.nih.gov](mailto:romeror@mail.nih.gov).
- » ***Establishment of a Clinical Perinatal Database and Bank of Biological Materials:*** This is an observational study that allows examination of materials from the mother (maternal blood, vaginal fluid, etc.) and umbilical cord blood. Placentas are collected after delivery. For more information on the study, please contact DR. ROBERTO ROMERO at [romeror@mail.nih.gov](mailto:romeror@mail.nih.gov).
- » ***Biomarkers of Disease in the Prediction of Preterm Delivery, Preeclampsia, and Intra-Uterine Growth Restriction:*** A Longitudinal Study: Patients are invited to participate in order to characterize the maternal plasma proteome, metabolome, lipidome, transcriptome, genome, etc. to identify biomarkers of obstetrical syndromes. Patients undergo monitoring of fetal growth and neonatal follow-up. For more information on the study, please contact DR. ROBERTO ROMERO at [romeror@mail.nih.gov](mailto:romeror@mail.nih.gov).
- » ***Characterization of the Boundaries of the Immune Response in Human Pregnancy:*** We will conduct a study that will allow us to define the boundaries of the immune response in normal pregnancy as well as in those destined to develop pregnancy complications, using state-of-the-art techniques developed by members of the Center for Human Immunology of NIH. Maternal blood will be obtained for deep immunophenotyping of circulating immune cells, the immune response to specific agents will be characterized, and the responses will be studied in the context of semi-allogenic and transplant pregnancy (egg or embryo donation). For more information on the study, please contact DR. ROBERTO ROMERO at [romeror@mail.nih.gov](mailto:romeror@mail.nih.gov).

## Reproductive Endocrinology and Gynecology

- » Research on reproductive disorders affecting the endometrium (such as recurrent implantation failure) using endometrial biopsy. Patients can contact DR. ALAN DeCHERNEY at [decherna@mail.nih.gov](mailto:decherna@mail.nih.gov), or 301-594-5494.
- » Research on reproductive function in sickle cell disease. Patients can contact DR. ALAN DeCHERNEY at [decherna@mail.nih.gov](mailto:decherna@mail.nih.gov), or 301-594-5494.
- » Research on ovarian stem cells and how they impact infertility. Patients can contact DR. ALAN DeCHERNEY at [decherna@mail.nih.gov](mailto:decherna@mail.nih.gov), or 301-594-5494.

## Maternal-Fetal Medicine Fellowship

The goal of the Fellowship is to train individuals to provide specialized patient care in Maternal-Fetal Medicine as well as to prepare candidates for a career in academic medicine as physician scientists. It is a three-year training program. There is the possibility of completing a combined Maternal-Fetal Medicine and Human Genetics Fellowship, and candidates can opt to complete a PhD, which is based in the Department of Physiology at Wayne State University.

The 18-month clinical rotations include: maternal-fetal medicine or high-risk obstetric service, obstetrical ultrasound, reproductive genetics, labor and delivery, anesthesia/intensive care unit, fetal echocardiography, and elective rotations. The program is housed at Hutzel Women's Hospital (with 5,000 deliveries per year), Detroit, and Faculty Members are Wayne State University appointees as well as Attendings of the Detroit Medical Center (DMC) in Detroit, MI. The program is approved for seven positions, two of which are funded by the Perinatology Research Branch (PRB), which is also housed at the DMC, and the remainder by the DMC itself. The Fellowship emphasizes clinical, translational, and basic research (18 months are dedicated to research). Ideal candidates for the Program are well trained individuals from a university program who wish to pursue a career in academic medicine, thrive in a rigorous and challenging environment, and are goal-oriented and self-motivated.

The Fellowship stresses a multi-disciplinary approach to the complications of pregnancy. There is a strong emphasis on prenatal diagnosis of congenital anomalies with ultrasound, and graduates are expected to be proficient in two-dimensional and three-dimensional ultrasound, fetal echocardiography, advanced imaging techniques such as Doppler, as well as ultrasound-guided invasive procedures such as amniocentesis. Opportunities for laboratory-based research and training are available at the PRB in the fields of parturition, reproductive immunology, placental pathology and biology, biomarker discovery, and systems biology in reproduction. Alternative opportunities are available at the C.S. Mott Center of Wayne State University.

The PRB's primary areas of interest are the mechanisms responsible for obstetrical disease, prediction and prevention of preterm birth, prenatal diagnosis of congenital anomalies, the role of infection and inflammation in perinatal disease, fetal growth, and development, placental pathology, and the use of high-dimensional biology techniques to identify biomarkers for preterm labor, preterm PROM (premature rupture of membranes), preeclampsia, fetal death, and IUGR (intrauterine growth restriction).

Detailed information about the training program is available at: <http://www.med.wayne.edu/prb>. The website also contains information about the faculty and their publications and awards. The Director of the Fellowship Program is Dr. Lami Yeo, and the Associate Director is Dr. Roberto Romero, Chief of the PRB. The Program is sponsored by the PRB, the DMC, and Wayne State University. Fellows are employees of the DMC, and program oversight is with the Office of Graduate Medical Education of the DMC.



## Medical or Pediatric Genetics Training Program

Clinical fellowship training in Medical or Pediatric Genetics is offered as a single program or in conjunction with training in Pediatric Endocrinology (and/or Internal Medicine and Endocrinology) at the National Institute of Child Health and Human Development (NICHD). Training in genetics is offered through NICHD's participation in the Medical Genetics fellowship programs of the National Institutes of Health (NIH) led by the National Human Genome Research Institute (NHGRI).

The NICHD also sponsors a combined medical genetics and pediatric endocrinology fellowship that leads to certification by both the American Board of Medical Genetics and the American Board of Pediatrics Sub-Board on Pediatric Endocrinology after 5–6 years of training (after approval by each Board).

Graduates of pediatrics or combined pediatrics/internal medicine residency programs, approved by the ACGME (Accreditation Council for Graduate Medical Education), in the United States who are either citizens or legal residents (green-card holders) of this country are eligible. We encourage applicants with previous PhD training or graduates of an MD/PhD program to apply for this unique fellowship, which aims to bridge two highly relevant sub-specialties of pediatric medicine: genetics and endocrinology.

This is an excellent opportunity for a physician-scientist in training who wishes to take advantage of the exciting opportunities offered by the NIH Clinical Center, the hundreds of state-of-the-art research laboratories at the NIH campus, and the commitment of the NIH leadership to training initiatives in translational research.

The program is headed by:

**Dr. Constantine A. Stratakis, MD, D(med)Sci**  
Scientific Director, NICHD, NIH  
Email: [stratak@mail.nih.gov](mailto:stratak@mail.nih.gov)

and

**Dr. Forbes D. Porter, MD, PhD**  
Clinical Director, NICHD, NIH  
Email: [fdporter@mail.nih.gov](mailto:fdporter@mail.nih.gov)

## NICHD–NIDDK Inter-Institute Endocrine Training Program

The Inter-Institute Endocrinology Training Program (IETP) seeks to train internal medicine physicians to become first-rate endocrinologists dedicated to investigative careers. The National Institute of Diabetes and Digestive and Kidney Diseases (NIDDK), the National Institute of Child Health and Human Development (NICHD), and the National Institute of Dental and Craniofacial Research (NIDCR) participate in the program, with faculty from all three institutes.

### Clinical and research training

Clinical training occurs largely in the first year. At any one time, fellows are responsible for five to ten patients on the inpatient service of the NIH. Under the supervision of the endocrine faculty, the trainee has complete responsibility for all aspects of a patient's care. Fellows make daily rounds, discuss patients with the attending physicians, and participate in management decisions related to both patient care and clinical investigation. Although all patients are admitted under peer-reviewed research protocols, there are many other aspects of diagnosis and patient care that fall entirely under the discretion of the endocrine fellows. During the second and third year, emphasis is placed on learning how to develop research questions, which enables fellows to investigate unusual disorders or particular scientific questions, and on maintaining clinical expertise. Fellows are also encouraged to participate in specific hypothesis-driven protocols.

The second and third year are spent primarily in laboratory or clinical research under the mentorship of a senior investigator in one of the several endocrinology branches of the NIH. During this research period, active clinical experience continues through bi-weekly continuity outpatient clinics (general endocrinology as well as diabetes clinics) and participation in clinical conferences. In addition, fellows on the endocrine service serve as consultants to the other services within the Clinical Center, where patients are not selected with regard to endocrine problems. Thus, fellows gain experience with several common problems of endocrine disease that may occur in any general medical ward. Clinical research activities include programs in all the areas of endocrine and metabolic disease. Study

**Ranganath Muniyappa, MD, PhD,**  
*Interim Director, Inter-Institute  
Endocrine Training Program;  
Diabetes, Endocrinology, and  
Obesity Branch, NIDDK*

**Michael T. Collins, MD,** *Director,  
Career Development and  
Research Oversight, NIDCR Senior  
Investigator, CSDB, NIDCR*

**Jenny E. Blau, MD,** *Associate  
Director, Inter-Institute Endocrine  
Training Program*

**Karel Pacak, MD, PhD, DSc,**  
*Head, Section on Medical  
Neuroendocrinology, NICHD*

**Constantine Stratakis, MD,**  
*D(med)Sci, Scientific Director  
and Head, Section on  
Endocrinology and Genetics,  
NICHD*

**Andrew Demidowich, MD,** *Staff  
Clinician*

**Fady Hannah-Shmouni, MD,**  
*Clinical Fellow*

**Marissa Lightbourne, MD,** *Clinical  
Fellow*

**HongXiu Luo, MD,** *Clinical Fellow*

**Ijeoma Muo, MD,** *Clinical Fellow*

**Sri Tella, MD,** *Clinical Fellow*

design, outcome measures, statistical analysis, and ethical and regulatory issues are stressed.

The IETP provides a comprehensive training experience that involves not only the NIH clinical branches working in Endocrinology but also the Georgetown University Hospital and Washington Hospital Center, both in the Washington area. The basic and clinical endocrine research facilities at the NIH are among the most extensive and highly regarded in the world. Thus, the fellowship is ideal for physicians who seek a broad education in both research and clinical endocrinology.

## Publications

1. Muo IM, Miller M, Goldberg AP. Considerations in favor of the use of fish oil for cardiovascular disease prevention and treatment in older adults. *J Aging: Res Clin Practice* 2014 3(4):191-195.
2. Hannah-Shmouni F, Demidowich A, Stratakis CA. Cortisol in the evaluation of adrenal insufficiency. *JAMA* 2016 316(5):535-536.
3. Hannah-Shmouni F, Trivellin G, Stratakis CA. Genetics of gigantism and acromegaly. *Growth Horm IGF Res* 2016 30:37-41.
4. Hannah-Shmouni F, Faucz FR, Stratakis CA. Alterations of phosphodiesterases in adrenocortical tumors. *Front Endocrinol (Lausanne)* 2016 7:111.
5. Tella SH, Kommalapati A. Thyrotoxic periodic paralysis: an underdiagnosed and under-recognized condition. *Cureus* 2015 7(10):e342.
6. Tella SH, Rendell MS. Glucagon-like polypeptide agonists in type 2 diabetes mellitus: efficacy and tolerability, a balance. *Ther Adv Endocrinol Metab* 2015 6(3):109-134.
7. Tella SH, Rendell MS. DPP-4 inhibitors: focus on safety. *Expert Opin Drug Saf* 2015 14(1):127-140.

## Collaborators

- Kenneth Berman, MD, *Director, Endocrine Training Program, Washington Hospital Center, Washington, DC*
- Rebecca Brown, MD, *Diabetes and Metabolic Disease Branch, NIDDK*
- Alan H. DeCherney, MD, *Section on Implantation and Oocyte Physiology, NICHD, Bethesda, MD*
- Rachel Gafni, MD, *Craniofacial and Skeletal Diseases Branch, NIDCR, Bethesda, MD*
- Phillip Gorden, MD, *Diabetes, Endocrinology, and Obesity Branch, NIDDK, Bethesda, MD*
- Stephen J. Marx, MD, *Metabolic Diseases Branch, NIDDK, Bethesda, MD*
- Lawrence Nelson, MD, *Office of the Clinical Director, NICHD, Bethesda, MD*
- Nicholas Patronas, MD, *Diagnostic Radiology, NIH Clinical Center, Bethesda, MD*
- James C. Reynolds, MD, *Nuclear Medicine Department, NIH Clinical Center, Bethesda, MD*
- William F. Simonds, MD, *Metabolic Diseases Branch, NIDDK, Bethesda, MD*
- Joseph Verbalis, MD, *Director, Endocrine Training Program, Georgetown University Medical Center, Washington, DC*
- Lee S. Weinstein, MD, *Metabolic Diseases Branch, NIDDK, Bethesda, MD*

## Contact

Adult Inter-Institute Endocrine Training Program (IETP)  
NICHD, NIDDK, NIDCR, NIH  
Bldg. 10, Rm 6-3940  
10 Center Drive, MSC 1613  
Bethesda, MD 20892-1613

Phone: 301-496-1913

Fax: 301-480-4517

Program Coordinator (NICHD):

Brittney Davis

[brittney.davis2@nih.gov](mailto:brittney.davis2@nih.gov)

Program Coordinator (NIDDK):

Sandra Wallace

[sandraw@mail.nih.gov](mailto:sandraw@mail.nih.gov)

Interim Program Director:

Dr. Ranganath Muniyappa

[muniyapr@niddk.nih.gov](mailto:muniyapr@niddk.nih.gov)

Associate Program Director:

Dr. Jenny Blau

[jenny.blau@nih.gov](mailto:jenny.blau@nih.gov)

Online Application: <https://www.aamc.org/services/eras/>

## Pediatric Endocrinology Inter-Institute Training Program

The Fellowship in Pediatric Endocrinology is a three-year, ACGME-accredited program. Applicants must have completed a residency in Pediatrics or Medicine/Pediatrics and be eligible to sit for the American Board of Pediatrics certification examination. Three fellows are accepted per year. The fellowship is based at the National Institutes of Health Clinical Center, which is one of the largest and most sophisticated research institutions in the United States. The program is conducted in partnership with Children's National Health System in Washington, DC. The fellowship is designed to provide clinical and research exposure that permits the development of academic Pediatric Endocrinologists with experience in both clinical and bench research.

### Program structure

The Pediatric Endocrinology Fellowship at NIH consists of one year of clinical training and two years of combined clinical and research training.

*First year.* A typical training schedule for first-year fellows includes six months at the NIH clinical research center, four months at Children's National Health Systems (CNHS), one month at The Johns Hopkins University Hospital, Baltimore, MD, and one month at Georgetown University Hospital, Washington, DC. Continuity clinics are held once a week and alternate between the NIH outpatient pediatric endocrine clinic and the diabetes and general endocrine outpatient clinics at CNHS. In addition, multi-disciplinary clinics in long-term follow-up for childhood cancer survivors, bone health, polycystic ovarian syndrome, disorders of sexual development, obesity, thyroid nodules, and cancer are offered. The Clinical Center maintains clinical research protocols involving the treatment of adrenal and pituitary tumors, congenital adrenal hyperplasia, McCune-Albright syndrome, disorders of sexual development, obesity, Cushing's syndrome, and others.

*Second and third years.* During the second and third years, mandatory clinical responsibilities are limited to a half-day continuity clinic per week and inpatient pediatric endocrine consultation on an on-call basis for three months per year. Fellows learn how to develop a research protocol, conduct a study, evaluate the results, and create

**Maya B. Lodish, MD, MHSc,**  
*Program Director, Pediatric  
Endocrine Fellowship, Staff  
Clinician, NICHD*

**Constantine A. Stratakis, MD,  
D(med)Sci, Scientific Director,**  
*NICHD*

Jeffrey Baron, MD, *Head, Section  
on Growth and Development,  
NICHD*

Rebecca Brown, MD, *Senior  
Clinical Fellow, Clinical  
Endocrinology Branch, NIDDK*

Angela Delaney, MD, *Assistant  
Clinical Investigator and Head,  
Unit on Genetics of Puberty and  
Reproduction, NICHD*

Rachel Gafni, MD, *Craniofacial and  
Skeletal Diseases Branch, NIDCR*

Margaret Keil, MS, CRNP, *Director,  
Pediatric Endocrine Clinical  
Services, NICHD*

Deborah Merke, MD, *Chief of  
Pediatric Services Clinical Center,  
NIH*

Kristina Rother, MD, *Head, Section  
on Pediatric Diabetes and  
Metabolism, NIDDK*

Jack Yanovski, MD, PhD, *Head,  
Section on Growth and Obesity,  
NICHD*

James Mills, MD, *Senior  
Investigator, Division of  
Epidemiology, Statistics, and  
Prevention Research, NICHD*

Stephanie Chung, MD, *Assistant  
Clinical Investigator, NIDDK*

Youn Hee Jee, MD, *Senior Fellow,  
NICHD*

Fetima Worthington, *Program  
Coordinator, NICHD*



### Fellows and faculty

From left to right, Constantine Stratakis (faculty), Cemre Robinson (fellow), Maya Lodish (faculty), and Miranda Broadney (fellow)

a presentation or manuscript suitable for publication. Fellows may choose to work in a laboratory setting, clinical setting, or both, and they perform state-of-the-art basic and clinical research closely supervised by internationally known mentors. During the first year, a research mentor is chosen and the fellow's progress is monitored by a Scholarship Oversight Committee. The overwhelming majority of our fellows go on to present their work at national and international meetings and choose academic careers following graduation.

## Additional information

The following URL provides more detailed information about the program: <http://pe.nichd.nih.gov>

## Application information

Applications are submitted through ERAS. The application must contain three letters of reference, medical school transcripts, USMLE scores, a personal statement, and a CV. The program participates in the NRMP match; pediatric endocrinology is now part of the fall subspecialty match. Applications must be submitted by August 31<sup>st</sup>, and interviews are conducted from September through November. Applicants must register with both NRMP and ERAS (<http://www.nrmp.org>, <https://www.aamc.org>).

## Contact

Maya Lodish, MD, MHSc, Program Director; [lodishma@mail.nih.gov](mailto:lodishma@mail.nih.gov), tel: 301-451-7175

Ms. Fetima Worthington, Program Coordinator; [fetima.worthington@nih.gov](mailto:fetima.worthington@nih.gov), tel: 301-451-1466

Pediatric Endocrinology Training Program  
NICHD, NIH  
Building 10, Room 9D42  
10 Center Drive  
Bethesda, MD 20892-1830

## Collaborators

- Andrew Bremer, MD, PhD, *Division of Diabetes, Endocrinology, and Metabolic Diseases, NIDDK, Bethesda, MD*
- Priya Vaidyanathan, MD, *Children's National Health System, Washington, DC*

## Contact

For more information, email [lodishma@mail.nih.gov](mailto:lodishma@mail.nih.gov) or visit <http://pe.nichd.nih.gov>.

## Reproductive Endocrinology and Infertility Training Program

The Intramural NICHD Reproductive Endocrinology and Infertility Training Program sponsors a three-year clinical fellowship in Reproductive Endocrinology and Infertility, which is accredited by the American Board of Obstetrics and Gynecology. The objective of this graduate medical education program is to train clinicians to serve as researchers and future leaders in the field of reproductive endocrinology with a view toward advancing basic, translational, and clinical science in reproduction. The program was started in 1978 and has since trained over 60 physicians in reproductive endocrinology. Upon completion of the rigorous scientific, clinical, and surgical curriculum, fellows may apply to the American Board of Obstetrics and Gynecology for certification in the subspecialty of Reproductive Endocrinology. The Fellowship in Reproductive Endocrinology and Infertility is served by faculty from four institutions: the *Eunice Kennedy Shriver* National Institute of Child Health and Human Development (NICHD), the Uniformed Services University of the Health Sciences (USUHS), Walter Reed National Military Medical Center (WRNMMC), and the Shady Grove Fertility Center. The program accepts civilian and military graduates of U.S. residencies in Obstetrics and Gynecology and has the mission to train reproductive endocrinology and infertility fellows who will serve as faculty in military, government, and academic institutions in order to establish and maintain high standards of training for students and residents in obstetrics and gynecology and to provide evidence-based, cutting-edge treatments to couples with infertility. Program graduates have become assistant, associate, and tenured professors and departmental chairs.

Fellows in the program rotate on clinical services of NICHD-supported intramural graduate medical programs in Medical and Pediatric Endocrinology as well as in Medical Genetics. The clinical training is robust. Thus, within the unique environment of the NIH, fellows participate in evaluation and management of rare and challenging endocrine conditions on the NIH Reproductive Endocrine Teaching Service. Clinical and surgical rotations take place at the Walter Reed National Medical Center and the Shady Grove Fertility Center. Research is strongly emphasized. Trainees in the program must complete a thesis project and may choose among any research laboratory in the Institute's intramural research program.

Alan H. DeCherney, MD, *Program Director*

Nicole Banks, MD, *Clinical Fellow*

Matthew T. Connell, DO, *Clinical Fellow*

Katherine Green, MD, *Clinical Fellow*

Mae W. Healy, DO, *Clinical Fellow*

Terrence D. Lewis, MD, PhD, *Clinical Fellow*

Carter Monique Owen, MD, *Combined Reproductive Endocrinology Infertility-Medical Genetics Clinical Fellow*

Nicole Doyle, MD, PhD, *Clinical Fellow*

Toral Parikh, MD, *Clinical Fellow*

Justin Pilgrim, DO, *Clinical Fellow*



To complete the research project, fellows are given 20 months of protected research time. The curriculum includes two university-base graduate courses, one in biostatistics and the other in reproduction. In the past year, faculty and fellows published 70 peer-reviewed articles. Over the past five years, graduates of the program published an average of five peer-reviewed manuscript associated with the training program, and several trainees received national recognition for excellence in research.

The three-year training program is structured to capitalize on the particular strengths and resources of each participating institution. Specifically, infertility services and operative care are provided by the busy clinical services at Walter Reed Bethesda Hospital, the NIH Clinical Center, and at the Shady Grove Fertility Center. Experience in the Assisted Reproductive Technologies (ART) is provided by rotation in the newly renovated, state-of-the-art Walter Reed Bethesda ART facility and in the Shady Grove Fertility Center. Fellows also obtain medical endocrine, pediatric endocrine, and genetic clinical training through rotation on the active inpatient services at the NIH Clinical Center. The program staff and fellows see 1,500 patients in the NIH Clinical Center in addition to conducting 40 surgeries and 50 oocyte retrievals per year. Outstanding research training is available either through NIH intramural laboratories in the *Eunice Kennedy Shriver* National Institute of Child Health and Human Development or at the Uniformed Services University of the Health Sciences. The program is intended to achieve synergistic interaction between the four sponsoring institutions and provide fellows with an experience and resources not available from a single institution.

Requirements for enrollment include graduation from a residency in Obstetrics and Gynecology in the United States that is accredited by the American Board of Obstetrics and Gynecology and an active medical license in the United States. Selection is competitive, and prospective candidates must register with the National Resident Matching Program (NRMP). Three positions are approved for a complement of nine fellow trainees. Trainees may meet criteria for the NIH Loan Repayment Program (LRP) for outstanding educational debt.

## Didactic instruction

Structured training includes a series of introductory seminars geared to first-year fellows, which take place from July to September of the first year. The introductory seminars provide a historical perspective and basic understanding of the practice of Reproductive Endocrinology. In a weekly NIH teaching rounds conference, fellows review and discuss challenging cases with faculty and fellows. In addition, all faculty and fellows of all years are expected to attend the weekly Pre-operative and Fellows' conferences. In addition, fellows attend weekly research conferences sponsored by the NICHD and present updates on thesis work at the weekly "Research in Progress Conference." Core Accreditation Council for Graduate Medical Education (ACGME) training objectives are covered in special NIH grand rounds and by courses at NIH or Walter Reed in Bethesda. NIH Endocrine Grand Rounds provide additional training in medical, pediatric, and reproductive endocrine conditions. Regular attendance at a monthly journal club is expected. Finally, fellows regularly attend ART clinical meetings, during which management of patients pursuing ART is discussed and outcomes are reviewed. In addition to larger groups, mentors of individual laboratories to which the fellow is affiliated generally meet on a weekly basis to review research progress. Furthermore, fellows are encouraged to participate in didactic training offered at national meetings, such as the *American Society for Reproductive Medicine*, the *Society for Reproductive Investigation*, and the *Society for the Study of Reproduction*. Moreover, fellows are encouraged to attend specialty meetings in their chosen interest areas, such as a Keystone meeting on hormone action.

## Contact

Reproductive Endocrinology and Infertility Training Program

NICHD, NIH

Bldg. 10CRC, Rm 1-3140

10 Center Drive

Bethesda, MD 20892-1109

Phone: 301-402-2141

Fax: 301-402-0884

Program Director:

Alan H. DeCherney, MD

[decherna@mail.nih.gov](mailto:decherna@mail.nih.gov)

Program Coordinator:

Marilyn Minor

[minormar@mail.nih.gov](mailto:minormar@mail.nih.gov)

Online Application: <http://www.socrei.org/for-learners/rei-fellow>

## Publications

1. Chaiworapongsa T, Romero R, Korzeniewski SJ, Chaemsaihong P, Hernandez-Andrade E, Segars JH, DeCherney AH, McCoy MC, Kim CT, Yeo L, Hassan SS. Pravastatin to prevent recurrent fetal death in massive perivillous fibrin deposition of the placenta (MPFD). *J Matern Fetal Neonatal Med* 2016 29:855-862.
2. Hill MJ, Royster GD, Healy MW, Richter KS, Levy G, DeCherney AH, Levens ED, Suthar G, Widra E, Levy MJ. Are good patient and embryo characteristics protective against the negative effect of elevated progesterone level on the day of oocyte maturation? *Fertil Steril* 2015 103:1477-1484.
3. Yu B, Russanova VR, Gravina S, Hartley S, Mullikin JC, Iqbal A, Graham J, Segars JH, DeCherney AH, Howard BH. DNA methylome and transcriptome sequencing in human ovarian granulosa cells links age-related changes in gene expression to gene body methylation and 3'-end GC density. *Oncotarget* 2015 6:3627-3643.
4. Falk M, DeCherney A, Kahn P. Mitochondrial replacement techniques implications for the clinical community. *N Engl J Med* 2016 374:1103-1106.
5. Plowden T, Schisterman E, Sjaarda L, Zarek S, Perkins N, Silver R, Galai N, DeCherney AH, Mumford S. Subclinical hypothyroidism and thyroid autoimmunity are not associated with fecundity, pregnancy loss, or live birth. *J Clin Endocrinol Metab* 2016 101:2358-2365.

## Contact

For more information, email [decherna@mail.nih.gov](mailto:decherna@mail.nih.gov).

## Administrative Management Branch

The Administrative Management Branch (AMB) in the Division of Intramural Research (DIR), NICHD, assists in the planning and managing of a variety of administrative management projects. The AMB provides administrative oversight for adherence to rules and regulations and expertise in administrative services to assure that the NICHD continues to move forward in its mission. The AMB staff are a key component and resource to the Scientific Director for the management and overall planning for the DIR.

The senior leadership within the AMB works directly with the Scientific Director and Deputy Scientific Director, particularly on strategic planning and administrative oversight, and plays a key role in maximizing the resources available to the DIR. The leadership provides guidance in all aspects of administration, represents the DIR at various NICHD programs and NIH-wide committees as well as focus groups concerned with administration.

The AMB administrative staff provide professional, technical, and administrative support in functional areas that further the mission of the DIR. The functional areas include, among others, budget and financial management, human resources, visas, travel, simplified acquisition, contract management and project officer support, safety and security, building and facilities management, timekeeping, program planning and evaluation, and general administrative services.

The AMB staff serve as a liaison between the laboratories/branches that they support and the many other entities at the NIH, such as the Office of the Scientific Director, NICHD; the Office of the Director, NICHD; the Office of Intramural Research, OD; the Fogarty International Center; Human Resources offices; the Office of Research Services including the Division of International Services; the Office of Research Facilities; and the Technology Transfer Branch.

### Contact

For more information, email [franciek@mail.nih.gov](mailto:franciek@mail.nih.gov) or visit <http://amb.nichd.nih.gov>.



*Francie Kitzmiller, Chief,  
Administrative Management  
Branch*

*Becky Preston, Deputy Branch  
Chief*

*Valerie Leftwood, Deputy Branch  
Chief*

## AMB Staff

Izet Beckwith, *Administrative Officer*  
Gina Elmore, *Administrative Officer – Budget*  
Dena Flipping, *Administrative Officer*  
Michelle Hudson, *Administrative Officer – Team Leader*  
Joy Kennedy, *Administrative Officer*  
Bonnie Lancey, *Administrative Officer*  
Lakeasha Mingo, *Administrative Officer – Team Leader*  
Charlene Patrick, *Administrative Officer – Team Leader*  
Mia Pulley, *Administrative Officer – Team Leader*  
Natacha Rene, *Administrative Officer*  
Nancy Richman, *Administrative Officer*  
Sylvia Robinson, *Administrative Officer – Procurement  
Lead*  
Marlene Taulton, *Administrative Officer*  
Beverley Todd, *Administrative Officer*  
Vincent Black, *Property Technician*  
Moona Braxton, *Property Technician*

Thomas Morgan, *Space Analyst*  
Steve Norris, *Space Analyst*  
Antoinette Dovidio, *Administrative Technician*  
Sara Drews, *Administrative Technician*  
Shante Washington, *Administrative Technician*  
Rebecca Bess, *Purchasing Agent*  
John Burton, *Purchasing Agent*  
Jax Chang, *Purchasing Agent*  
Towanda Daniels, *Purchasing Agent*  
Roshonna Davis, *Purchasing Agent*  
William Davis, *Purchasing Agent*  
Jodi Ferrell, *Purchasing Agent*  
Sherry Jones, *Purchasing Agent*  
Brittany May, *Purchasing Agent*  
David Shen, *Purchasing Agent*  
Hanumanth Vishnuvajjala, *Purchasing Agent*

## Research Animal Medicine Branch

The Research Animal Medicine Branch (RAMB) is responsible for directing the program of laboratory animal care and use for NICHD's Division of Intramural Research (DIR). The program includes animal facilities managed by NICHD as the lead institute, NICHD animals housed in other facilities, and all activities involving animals owned by the NICHD DIR. The Branch's activities include the following: 1) providing primary veterinary care; 2) advising the NICHD Scientific Director on animal care and use practices; 3) insuring that animal use within DIR is in accordance with applicable regulatory standards; 4) coordinating intramural animal use, including appropriate animal model selection, support requirements, and Animal Study Proposal review; 5) advising scientific staff on comparative medicine, Animal Study Proposal design, disease interference, and on other factors that may complicate or invalidate research results; 6) implementing and coordinating animal health monitoring; 7) coordinating quarantine for incoming animals of unknown health status to prevent the introduction of agents pathogenic to humans or animals; 8) coordinating a central animal ordering program for the NICHD; 9) providing administrative management of the NICHD Animal Care and Use Committee (ACUC); and 10) interfacing with organizations and institutions concerned with the ethical and humane care and use of animals in research.

### **RAMB supports animal use research in the NICHD Division of Intramural Research.**

The RAMB operates and manages the Building 6B Shared Animal Facility (SAF), the NIH Animal Center (NIHAC) SAF, Suite 6C127 of the Ambulatory Care Research Facility (ACRF) Animal Facility, and the NICHD aquatics facilities. The DIR Animal Program and ACUC have oversight over these facilities with regard to animal use as well as over NICHD and NIA (National Institute on Aging) animals in the Porter Neurosciences Research Center (PNRC) SAF and the Building 10A Central Animal Facility (CAF). The RAMB has contractual oversight over an aquatic animal husbandry task that includes husbandry and research support for NICHD, NHGRI, NHLBI, and NCI.

The Building 6B SAF supports the animal research activities of three Institutes (NICHD, NEI, and NIAMS) in a restricted-access,



**Joseph M. Schech, DVM, Head,**  
*Research Animal Management  
Branch*

Ruth A. Woodward, DVM, *Deputy  
Animal Program Director; Facility  
Veterinarian, NIHAC Shared  
Animal Facility*

Tannia S. Clark, DVM, *Facility  
Veterinarian, 6B Shared Animal  
Facility/6 Shared ZF Facility*

Daniel T. Abebe, MS, *Research  
Technician*

Julie A. Jacobs, *Facility Manager,  
NIHAC Shared Animal Facility*

Christopher M. Rishell, BS, *Facility  
Manager, 6B Shared Animal  
Facility*

Lauren Pandolfo, MS, *Aquatics  
Facility Manager*

Klara Post, MS, *Animal Care and  
Use Committee Coordinator*

disease-free rodent facility; it also includes a room for *Xenopus*.

The NIHAC SAF supports the animal research activities of the NICHD. This facility houses nonhuman primates. Animal holding areas include indoor housing and indoor/outdoor runs.

Suite 6C127 of the ACRF Animal Facility supports the animal research activities of the NICHD. The facility occupies 121 m<sup>2</sup> (1,299 ft<sup>2</sup>) in Building 10 and has five animal rooms and two procedure rooms and provides care and housing for rodent and aquatic species. It is a restricted-access, conventional facility and is operated under contract.

The Building 6 Shared Zebrafish Facility (SZF) supports NICHD and NHGRI with 15,000 2-liter tanks; the total capacity of the SZF is approximately 330,000 zebrafish.

As part of the NIH, the RAMB participates in the formulation of policies and procedures that impact the care and use of laboratory animals throughout the country. In 2011, the RAMB led the effort for triennial re-certification by the Association for the Assessment and Accreditation of Laboratory Care, International (AAALACi). The RAMB and various animal-user investigators have been active contributors to the NIH Animal Research Advisory Committee's (ARAC) efforts to adopt the new "Guide to Care and Use of Laboratory Animals," which is a primary-source set of guidelines used by the AAALACi and the NIH Office of Animal Welfare.

## *Additional Funding*

- In addition to direct funding by the Intramural Research Programs of NICHD, the RAMB is also funded by facility users from other NIH Institutes and Centers.

## *Contact*

For more information, email [schechj@mail.nih.gov](mailto:schechj@mail.nih.gov) or visit <http://www.animalcare.nichd.nih.gov>.

## NICHD Biomedical Mass Spectrometry Core Facility

The NICHD Biomedical Mass Spectrometry Core Facility was created under the auspices of the Office of the Scientific Director to provide high-end mass-spectrometric services to scientists within the NICHD Division of Intramural Research (DIR). Particular focus has been in the areas of proteomics, biomarker discovery, protein characterization, and detection of post-translational modifications. The Facility also performs quantitative analyses of small biomolecules, including lipids and steroids. In addition, the Facility develops and modifies methods for the isolation and detection of biomolecules by mass spectrometry, as well as novel methods for data analysis. The Facility is located in the 9D corridor of Building 10 on the NIH campus. The Mass Spectrometry Facility currently serves 9–12 laboratories within the NICHD intramural research program, representing about 30 projects, as well as two PIs of sister institutes on the NIH campus and collaborations with five outside institutions.

The Facility is committed to promoting mass-spectrometric aspects of proteomics and other mass-spectrometric analyses in NICHD's DIR. We make serious efforts to educate investigators on the benefits and pitfalls of the techniques used in the Facility. In particular, we provide coaching on the principles of appropriate methods for sample isolation and staining of gels. We also support an NIH-wide seminar series featuring internationally known experts in proteomics. In parallel, the staff of the Facility have developed collaborations with other Institutes to promote exchange of information and to bring new mass-spectrometric techniques to NICHD. In addition, Peter Backlund is the moderator of the NIH Mass Spectrometry Interest Group.

### Mode of operation

The Facility is available to all labs within the DIR, provided that existing resources are distributed equally among investigators requesting services. The philosophy of the Facility is to ensure that its instruments obtain only reliable, high-quality data and that its clients receive only statistically meaningful analyses. The Facility's staff are available for consultation on both project design and data interpretation. Before the start of a project, staff members meet with the Principal Investigator (PI) and other scientists involved



**Peter S. Backlund, PhD, Staff Scientist, Acting Director**  
Vince Pozsgay, PhD, *Staff Scientist*  
Nancy E. Vieira, MS, *Senior Research Assistant*  
Alfred L. Yergey, PhD, *Scientist Emeritus*

in each study to discuss experimental goals and data requirements. The Facility has an internationally recognized capability in the characterization of proteins and peptides by mass spectrometry, including: (1) identification of proteins isolated by electrophoresis; (2) confirmation of molecular weights of recombinant or synthetic proteins and peptides; (3) determination of sites of specific post-translational modifications including phosphorylation, glutamylation, AMPylation, and disulfide bond formation; (4) quantification of specific post-translational modifications; and (5) sequencing of peptides *de novo*. In addition, the Facility has extensive experience and skill in the identification and quantification of small endogenous molecules including phospholipids, steroids, and sugars. In this latter area, the capability is primarily in quantification of endogenous levels of particular molecules and their metabolites.

## Instrumentation

The facility currently has four mass spectrometers in use for specific areas of analysis.

*SimulTOF 300 MALDI TOF/TOF*: The state-of-the-art high-performance MALDI (matrix-assisted laser desorption/ionization) TOF/TOF (time-of-flight/time-of-flight) instrument can be operated in either positive- or negative-ion modes. The instrument is most often used for peptide identification in peptide mixtures without chromatographic separation. Methodology is also available to perform off-line liquid chromatography (LC) separation and sample spotting. Additional uses include relative peptide quantification for iTRAQ (isobaric tags for relative and absolute quantitation)-labeled peptides and sequence determination through *de novo* sequencing techniques for unusual peptides not present in gene-based protein databases.

*Agilent 6560 Ion Mobility-qTOF*: The state-of-the-art instrument couples a one-meter ion-mobility-drift cell with a high-resolution qTOF mass spectrometer. Ion-mobility spectrometry (IMS) provides an added dimension of sample separation that is orthogonal to both chromatography and mass spectrometry. The instrument is currently used to determine collision cross-section measurements of ions for small molecules and intermolecular complexes and for separation and analysis of complex mixtures of lipids and peptides.

*Agilent 6460 LC-ESI QqQ (Triple Quad)*: The instrument is currently used for small-molecule analysis and quantification, principally for steroid profiling and the analysis of amino acid and glycolytic pathway metabolites.

*ABI Voyager MALDI TOF*: The instrument is used for the analysis of protein mixtures and to verify molecular weights of intact proteins. It is also available for general use after a prospective user has undergone appropriate training.

## Major projects

### IMPROVED METHOD FOR PROTEIN IDENTIFICATION BY ANALYSIS OF BOTH MS AND MS/MS SPECTRAL DATA

We developed a method for protein identifications based on the combined analysis of MS and MS/MS spectral data collected from tryptic digests of proteins in gel bands using MALDI TOF-TOF instrumentation. The method uses theoretical peptide masses and the measurement errors observed in the matched MS spectra to confirm protein identifications obtained from a first-pass MS/MS database search. The method makes use of the mass accuracy of the MS1-level spectral data that heretofore were ignored by most peptide database search engines. We developed a probability model to analyze the distribution of mass errors of peptide matches in the MS1 spectrum and to thus provide a confidence level to the additional peptide



matches. The additional matches are independent of the MS/MS database search identifications and provide additional corroboration to identifications from MS/MS-based scores that are otherwise considered to be of only moderate quality. Straightforward and easily applicable to current proteomic analyses, this 'ProteinProcessor' provides a robust and invaluable addition to current protein identification tools (Reference 1).

### PROTEIN QUANTIFICATION IN TISSUES AND CEREBRAL SPINAL FLUID (CSF) USING ISOBARIC TAGS

Protein quantification is an important aspect of proteome characterization and is crucial to understanding biological mechanisms and human diseases. Discovery-based or un-targeted studies have often used covalent tagging strategies (i.e., iTRAQ®, TMT™), which use reporter ion signals collected in the tandem MS experiment for quantification. However, it has been difficult to establish the relative changes in reporter ion signals that are required to detect significant changes at the protein level. We studied the behavior of iTRAQ 8-plex chemistry using MALDI-TOF/TOF instrumentation. To better understand the behavior of the reporter ions, we evaluated the use of within-spectra normalization, which we termed "row-normalization." When applied to replicate protein mixtures of equal concentration, we found the reporter ion ratios to have a normal Gaussian distribution around the expected ratio of 0.125. Therefore, the width of the distribution can be used to establish a confidence level for a given reporter ion ratio (Reference 3). The method is being applied to a study of CSF from patients with Smith-Lemli-Opitz syndrome (SLOS) or Niemann-Pick disease, type C1 (NPC-1), in order to profile protein changes and identify biochemical alterations correlated with disease progression and treatments.

### ION MOBILITY MASS SPECTROMETRY FOR DETECTION OF ISOBARIC LIPIDS AND ION COMPLEXES

The Agilent Model 6560 Ion Mobility Q-TOF LC/MS instrument combines an ion mobility drift cell in front of a high-resolution Q-TOF mass spectrometer. Implementing ion mobility spectrometry (IMS) prior to mass analysis adds a dimension of separation to sample analysis that is orthogonal to both chromatography and mass spectrometry. Given that IMS operates on a millisecond time scale, the device offers the ability to perform separations of complex mixtures much faster than is possible with liquid chromatography (LC). In addition, IMS separations are associated with the collision cross section (CCS) of ions (CCS is essentially a 'shape' parameter of ions in the gas phase), so that molecules of identical molecular weights can be separated on the basis of their CCS, which has implications for separations of isobaric biomolecules, including numerous steroids, lipids, and peptides. IMS also offers the ability to study intermolecular complexes and determine their stoichiometry. One of the first studies we undertook was to investigate beta-cyclodextrin-cholesterol complexes; preliminary results of the measurements suggest formation of a trimeric complex that incorporates calcium ions as a bridge. In addition, pH-dependent changes in cyclodextrin conformations were suggested by the observation of two distinct drift times of isobaric species and by an indication of changes in CCS attributable to two distinct conformations of the ions. We have begun molecular modeling studies of the cyclodextrin molecules to explain the two conformational states.

We used combined ion-mobility/mass spectrometry to analyze complex extracts of phospholipids to analyze branched-chain fatty acid incorporation into phosphatidylcholine (PC) in mice fed a diet supplemented with phytol, a saturated C20 branched-chain alcohol. Phytol is metabolized to phytanic acid, which can be incorporated into phospholipids and triglycerides. Muscle-tissue lipids were extracted and then analyzed by ion-mobility/mass spectrometry. The muscle phosphatidylcholine species profiles of the phytol and control diet were similar, except that some additional species were detected in the phytol-diet muscle. We

tentatively identified the two most abundant novel species ( $m/z$  790.7 and 862.7) as PC 20:0-16:0 and PC 20:0-22:6. To confirm the presence of phytanic acid in these PC's, we compared the ion mobility of these species with a diphytanoyl PC standard and endogenous straight-chain PC phospholipids; the ion mobility of the novel PC species was consistent with incorporation of one branched chain phytanic acid.

### QUANTITATION OF PLASMA MELATONIN (5-METHOXY-N-ACETYLTRYPTAMINE) AND N-ACETYLTRYPTAMINE

We developed a multiple-reaction-monitoring (MRM)-based assay to quantify *N*-acetyltryptamine and melatonin in plasma. *N*-acetyltryptamine is a melatonin-receptor mixed agonist/antagonist. The assay provided the first evidence for the presence of *N*-acetyltryptamine in plasma from human, rat, and rhesus monkey. The LC/tandem mass spectrometric method employs deuterated internal standards to quantitate *N*-acetyltryptamine and melatonin. *N*-acetyltryptamine was detected in daytime plasma from human volunteers, rhesus macaques, and rats. Twenty-four-hour studies of rhesus macaque plasma revealed increases in *N*-acetyltryptamine at night to concentrations that exceed those of melatonin. The findings establish the physiological presence of *N*-acetyltryptamine in the circulation and support the hypothesis that this tryptophan metabolite plays a significant physiological role as an endocrine or paracrine chronobiotic through actions mediated by the melatonin receptor.

### MASS SPECTROMETRY-BASED PROFILING OF URINARY STEROIDS

We developed a novel un-targeted LC-MS/MS approach to profile urinary steroids, which permits detection of steroids that have truly changed in a patient cohort without prior knowledge of the steroids' identity (i.e., untargeted metabolomics of steroids). Initial studies in polycystic ovary syndrome (PCOS) patients detected elevated levels of an unknown compound consistent with an androgenic steroid. We were then able to identify the unknown as a mixture of androsterone-sulfate and etiocholanolone-sulfate. We are extending the approach to additional PCOS patients and to studies on patients with congenital adrenal hyperplasia (CAH). We also developed a targeted assay to quantitate specific urinary steroids, using an MRM (multiple reaction monitoring) assay for quantification of 5- $\alpha$ -pregnane-3- $\alpha$ ,17- $\alpha$ -diol-20-one (known also as pdiol) and its 5- $\beta$  stereoisomer, 17- $\alpha$ -hydroxypregnanolone (known also as 5- $\beta$ -pdil); pdiol is an intermediate in the 'backdoor pathway' from 17OH progesterone to dihydrotestosterone. Using this assay in a study of CAH patients, we found urinary levels of both pdiol and 5- $\beta$ -pdil to be directly correlated with the serum levels of androstenedione (Reference 2). In addition, we began to develop a product-ion spectrum database of known steroids to improve our ability to identify novel urinary steroids.

### IDENTIFICATION OF LECT2-ASSOCIATED AMYLOIDOSIS IN ADRENAL TISSUE

We recently identified leukocyte cell-derived chemotaxin-2 (LECT2) as a component in the formation of amyloid plaques in adrenal tissue (Reference 5). Although the adrenal tissue from a patient was positive for amyloid by Congo Red staining, specific immuno-staining for proteins commonly known to form amyloid plaques were all negative. We extracted plaque proteins from disease tissue and separated them by 1D SDS/PAGE. After digestion of the gel bands, we identified serum amyloid P-component and leukocyte cell-derived chemotaxin-2 (LECT2) in the plaques (Reference 5). Other reports had previously observed LECT2 in amyloid plaques in kidney, but this is the first observation of LECT2 amyloidosis in adrenal tissue. We confirmed the high accumulation of LECT2 in adrenal amyloid plaques from this patient by Western blots (using a LECT2-specific antibody), which were positive for the disease tissue but negative for comparable amounts of tissue from normal adrenal glands.

## Publications

1. Epstein JA, Blank PS, Searle BC, Catlin AD, Cologna SM, Olson MT, Backlund PS, Coorsen JR, Yergey AL. ProteinProcessor: probabilistic analysis using mass accuracy and the MS spectrum. *Proteomics* 2016 16:2480-2490.
2. Debono M, Mallappa A, Gounden V, Nella AA, Harrison RF, Crutchfield CA, Backlund PS, Soldin SJ, Ross RJ, Merke DP. Hormonal circadian rhythms in patients with congenital adrenal hyperplasia: identifying optimal monitoring times and novel disease biomarkers. *Eur J Endocrinol* 2015 173:727-737.
3. Cologna SM, Crutchfield CA, Searle BC, Blank PS, Toth CL, Ely AM, Picache JA, Backlund PS, Wassif CA, Porter FD, Yergey AL. An efficient approach to evaluate reporter ion behavior from MALDI-MS/MS data for quantification studies using isobaric tags. *J Proteome Res* 2015 14:4169-4178.
4. Pu J, Schindler C, Jia R, Jarnik M, Backlund P, Bonifacino JS. BORC, a multisubunit complex that regulates lysosome positioning. *Dev Cell* 2015 33:176-188.
5. Rauschecker ML, Cologna SM, Xekouki P, Nilubol N, Shamburek RD, Merino M, Backlund PS, Yergey AL, Kebebew E, Balow JE, Stratakis CA, Abraham SB. Clinical Case Report: LECT2-associated adrenal amyloidosis. *AACE Clinical Case Reports* 2015 1:e59-e67.

## Collaborators

- Paul Blank, PhD, *Section on Cellular and Membrane Biophysics, NICHD, Bethesda, MD*
- Juan S. Bonifacino, PhD, *Section on Intracellular Protein Trafficking, NICHD, Bethesda, MD*
- Jens R. Coorsen, PhD, *University of Western Sydney, Sydney, Australia*
- Thomas E. Dever, PhD, *Section on Protein Biosynthesis, NICHD, Bethesda, MD*
- Peter Harrington, PhD, *Ohio University, Athens, OH*
- David C. Klein, PhD, *Section on Neuroendocrinology, NICHD, Bethesda, MD*
- Stephen H. Leppla, PhD, *Laboratory of Parasitic Diseases, NIAID, Bethesda, MD*
- Matthias Machner, PhD, *Section on Microbial Pathogenesis, NICHD, Bethesda, MD*
- Joan Marini, MD, PhD, *Section on Heritable Disorders of Bone and Extracellular Matrix, NICHD, Bethesda, MD*
- Deborah P. Merke, MD, MS, *Pediatric Consult Service, NIH Clinical Center, Bethesda, MD*
- Matthew Olson, MD, *The Johns Hopkins University Medical School, Baltimore, MD*
- Forbes Porter, MD, PhD, *Section on Molecular Dymorphology, NICHD, Bethesda, MD*
- Dan Sackett, PhD, *Section on Cell Biophysics, NICHD, Bethesda, MD*
- Brian Searle, *Proteome Software, Inc., Portland, OR*
- Yuri V. Sergeev, PhD, *Ophthalmic Genetics and Visual Function Branch, NEI, Bethesda, MD*
- Stephen E. Stein, PhD, *National Institute of Standards and Technology, Gaithersburg, MD*
- Gisela Storz, PhD, *Section on Environmental Gene Regulation, NICHD, Bethesda, MD*
- Constantine A. Stratakis, MD, D(med)Sci, *Section on Endocrinology and Genetics, NICHD, Bethesda, MD*
- Joshua Zimmerberg, MD, PhD, *Section on Cellular and Membrane Biophysics, NICHD, Bethesda, MD*

## Contact

For more information, email [backlunp@mail.nih.gov](mailto:backlunp@mail.nih.gov).

## The NICHD Zebrafish Core

The NICHD Zebrafish Core was established in May 2012. The goal of the Core is to provide its clients with consultation, access to equipment and reagents, and service in the area of zebrafish genetics. NICHD investigators as well as investigators from other NIH institutes and from outside the NIH are its clientele. The oversight committee for the Core comprises Thomas Sargent (Chair), Harold Burgess, Ajay Chitnis, Igor Dawid, and Brant Weinstein. The Core's activities consist of (1) oversight and support of client-specific projects; (2) maintenance and improvement of equipment and infrastructure; (3) core-initiated research, also in the field of developmental biology; and (4) service and educational outreach.

### Oversight and support of client-specific projects

In the past year, we engaged in research projects with seven labs: four from NICHD, one from NCI, one from NHLBI, and one from the Children's National Medical Center.

*Porter Lab (NICHD): Zebrafish models of human pediatric diseases.*

Smith-Lemli-Opitz syndrome (SLOS) is an autosomal recessive, multiple malformation syndrome with pediatric onset characterized by intellectual disability and aberrant behavior. Phenotypic characterization is ongoing of zebrafish carrying mutant alleles of *dhcr7*, the zebrafish ortholog to human *DHCR7* gene, which were generated with support from the Core in previous years. This project will continue in 2017. The Core also created three novel lines for the Porter lab, carrying mutations in either the *npc1*, *npc2*, or *cln3* gene. Phenotypic characterization by the Porter lab is ongoing.

*Stratakis Lab (NICHD): Function of zebrafish orthologs to human genes implicated in disorders of the pituitary-adrenal axis.* Gigantism arises due to excess growth hormone secretion during childhood, before the growth plates close. Since 2012, the Core has supported this lab's investigation of the zebrafish ortholog to a human gene implicated as a driver of gigantism. The lab published a paper in June 2016, with Feldman as co-author, which included a description of the gene's developmental expression in zebrafish. This year, the Stratakis lab also began to test the effect on growth and development of zebrafish



**Benjamin Feldman, PhD, Staff Scientist and Director of the NICHD Zebrafish Core**

**ChonHwa Tsai-Morris, PhD, Staff Scientist and Assistant Director of the NICHD Zebrafish Core**

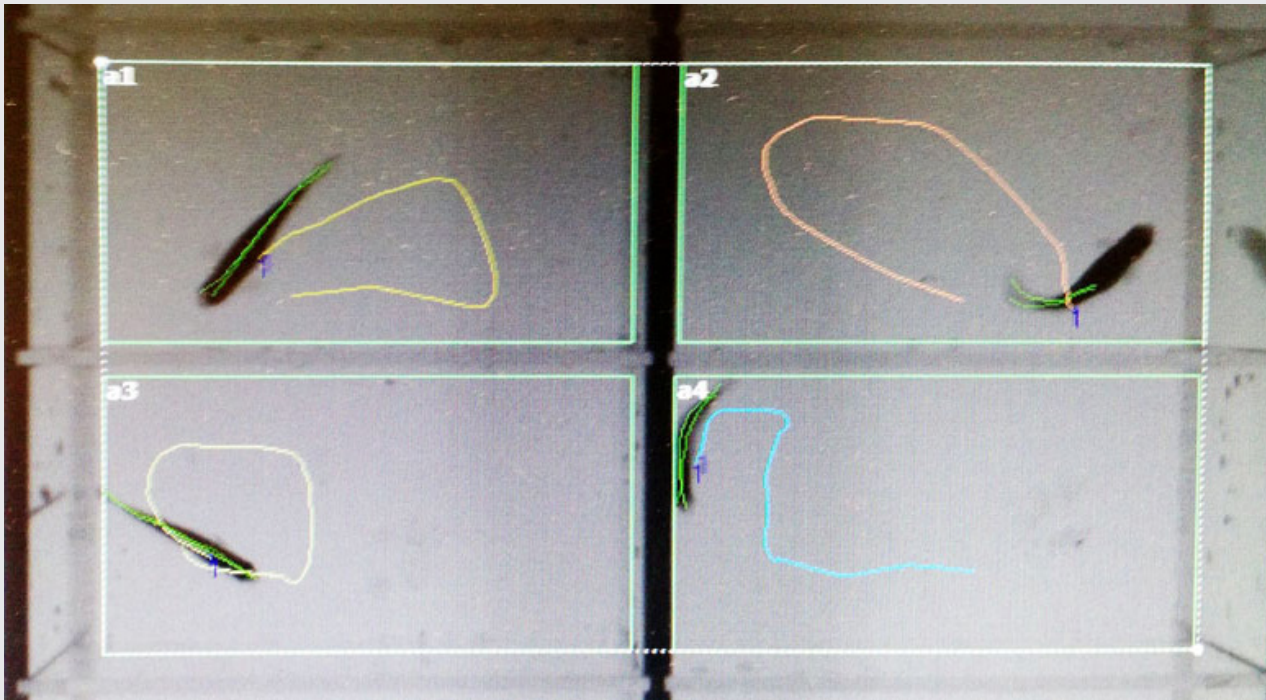

FIGURE 1. Screen shot of tracking software for measuring swimming zebrafish

in which this gene is chronically overexpressed in tissue-specific or ubiquitous locations, using the Gal4/UAS transgene system. The studies will continue in 2017. This year, the Core used Crispr/Cas9 methods to generate for the Stratakis lab zebrafish carrying loss-of-function mutations in the above gene as well as in three other zebrafish orthologs to genes implicated human growth anomalies. Characterization of the resulting phenotypes will begin in 2017.

Since 2012, the Core has also supported this lab's investigation of the function of two zebrafish orthologs to human adrenal hyperplasia genes. Over previous years, the Core helped the lab generate and acquire zebrafish carrying loss-of-function mutation for each of these orthologs. Phenotypic characterization has begun this year; notable effects on juvenile growth in the case of one gene and on early embryogenesis in the case of the other were found. This project will continue into 2017.

*Kaler Lab (NICHD). Modeling copper deficiency-associated distal motor neuropathy.* The Menkes' gene encodes ATP7A, a copper-binding ATPase localized to the plasma membrane and the trans-Golgi network, which is critical for proper intracellular copper distribution. Two ATP7A missense mutations cause a milder syndrome than Menkes disease, a distal motoneuropathy that is nevertheless debilitating to children and young adults. Since 2013, the Core has supported a project to clarify the structure-function relationship of ATP7A and motor neuron defects from the perspective of these missense mutations. This project was awarded a Bench-to-Bedside grant, with \$10,000 per annum funding to the NICHD Zebrafish Core through FY 2016–2017. Over previous years, the Core supported the Kaler lab's work to visualize and compare motor neuron

growth during embryogenesis of wild-type zebrafish embryos and embryos homozygous for null mutations in their ATP7A ortholog, *atp7a*. The comparison will continue into 2017. In parallel with these studies, Feldman and Tsai-Morris have made a concerted effort to establish genome-editing technology in the Core, with the initial goal of inducing formation of zebrafish *atp7a* point mutations cognate to one of the human *ATP7a* motoneuropathy alleles. As described above, this work will continue into 2017.

*Tanner Lab (NCI). Assessing human metastatic cell behaviors in a whole-body (zebrafish embryo) microenvironment.* The dual goal of this project is to (1) determine the trophic range of certain metastatic melanoma and breast carcinoma cell lines and (2) document cellular dynamics during early tumor formation from metastatic cells that have seeded into new microenvironments. Feldman assisted the Tanner lab during the inception phase in 2013–2014 and to a lesser degree in 2014–2015. The Tanner lab worked mostly independently in 2015–2016 and the Core’s chief role has been to maintain and manage access to needed equipment, fish tank space, and reagents. The Tanner lab has developed independent resources and will not need any further core support 2017.

*Tuchman Lab (Children’s National Medical Center). Finding neuroprotective drugs to mitigate hyperammonemia, a consequence of urea cycle defects and liver failure.* Exposure of the brain to high ammonia causes neurocognitive deficits, intellectual disabilities, coma, and death. Since 2012, the Core has helped this lab use zebrafish embryos to identify small molecules able to diminish the effects of hyperammonemia. Over previous years, a library of hundreds of small molecules with known safety profiles for humans was screened, and several promising candidates were identified for follow-up validation studies in zebrafish and other animal models. This year, the Core helped the Tuchman lab increase throughput of this screen, bolstered by additional personnel from the Tuchman lab and by the Core’s implementation of NICHD’s massive embryo production systems as a source of embryos.

## Maintenance and improvement of services, equipment, and infrastructure

The ‘do-it-yourself and pay-as-you-go’ model of facilitated, supervised research is working well and continues for complex and ad hoc projects. Additional ad hoc services include participation in monthly project-specific meetings, RNA syntheses, zebrafish line preservation via sperm freezing, and line recovery via *in vitro* fertilization. The core now also offers to generate zebrafish carriers of novel mutant alleles as a fee-for-service.

The Core also acquired the following: a state-of-art automated whole-mount *in situ* hybridization machine; a new camera and microscope adaptor components to establish a new photomicroscopy station; a portable UV illumination system and microscope blackout hood to visualize fluorescent zebrafish lines in the lab and for educational outreach activities. A new generation of wild-type zebrafish was introduced and new generations were established for other mutant and transgenic lines frequently needed for Core projects and/or educational outreach. The Core also added a new line of fish to its collection: a ubiquitously expressed Gal4 line.

## Adopting emerging reverse genetic tools

Crispr/Cas9 technology has made gene targeting in zebrafish straightforward and has opened the door to more elaborate genetic modifications, widely referred to as “precise gene editing.” Over the past year, the Core acquired, adapted, and optimized reagents and protocols for Crispr/Cas9 gene disruption. The project has been greatly bolstered by the addition of a second Staff Scientist to the NICHD Zebrafish Core: Chon-

Hwa Tsai-Morris. Dr. Tsai-Morris's main assignment has been to improve these genetic tools and generate mutants for NICHD Zebrafish Core customers, as a new service. The Core has thus created and provided zebrafish carrying novel mutations in 15 distinct genes for the Weinstein, Sargent, Stratakis, Porter, and Kaler labs. In the process of getting Crispr-Cas9 up and running, the Core targeted an additional nine genes, for an overall success rate of over 75% per locus-specific disruption construct, known as a gRNA. The Core also established an optional quality-control strategy for selecting maximally mutagenized lines, which will be particularly useful for zebrafish and Crispr/Cas9 newcomers. The above data were presented at the Spring 2016 Mid-Atlantic Regional Zebrafish Meeting, the Spring 2016 Mid-Atlantic Regional Society for Developmental Biology Meeting, and the 2016 Allied Genetics Conference.

As part of a Bench-to-Bedside-funded project with the Kaler lab, the Core most recently began to explore and compare strategies for precise genome editing, whereby Crispr/Cas9-based gene disruption reagents are combined with a DNA donor sequence in order to generate zebrafish carrying *atp7a* point mutations; these are homologous to human *ATP7A* point mutations that the Kaler lab is studying in a class of patients with distal motoneuropathy. Precise gene editing is not as efficient as gene disruption, and zebrafish labs have reported varying levels of success, with relatively labor-intensive strategies required throughout. Through literature review and discussions at conferences, Feldman and Tsai-Morris selected two methods as the most promising. Using an initial gRNA targeting the *atp7a* gene and a single-stranded DNA donor sequence, we found that pre-synthesized Cas9 protein is better suited than *in vitro*-synthesized Cas9 RNA, data that was presented by Feldman in a late-breaking data talk at the 2016 Allied Genetics Conference. We also found that new gRNA target sites were likely needed. Accordingly, we identified an additional six gRNA targets in the *Atp7a* gene and found that two could be disrupted at suitable levels.

Future work will utilize these targets to test two classes of DNA donor sequences, respectively. First, we will use a gRNA site in one of *Atp7a*'s exons in combination with a single-stranded DNA donor for homology-directed repair. Second, we will use a gRNA site in an adjacent intron in combination with linearized double-stranded DNA for homologous recombination.

## Development of other tools to facilitate research with zebrafish at NICHD

*Automating immunohistochemistry.* A great deal of researcher time and effort goes into the manual processing of zebrafish embryos and tissue samples. Automated liquid exchange instruments can reduce the labor, but some models, including the Core's recently retired model, required a prohibitively large antibody volume, leaving researchers using valuable antibodies with no automated option. To remedy this, the Core acquired a smaller-volume liquid-exchange system in November 2015, which is also designed for whole-mount procedures (Intavis Insitu Pro). The machine can also be used for immunohistochemistry of tissues from other organisms. Protocols for visualizing and localizing gene expression at both the protein and RNA levels were adapted to this instrument. To permit further reduction in the volume of valuable liquid reagents, the Core designed and 3D printed an adaptor sleeve, with help from Harold Burgess's lab. Protein detection works very well, but the sensitivity of RNA detection does not yet match manual protocols. Future work, therefore, will be to identify protocol modifications that increase the sensitivity of RNA detection. Future work will also test an alternate tissue-holding unit to further reduce the required volume of valuable liquid reagents.

*Implementing mass embryo production.* As part of the Central Aquatics Facility, NICHD has two large and two small mass embryo-production systems (MEPS), distributed between two of our procedure rooms. Initial

optimization by the Research Animal Management Branch (RAMB) and Charles River staff already had one of the two larger MEPS running on a continuous basis, with one embryo collection per week. However, NICHD research through the Core and otherwise requires embryos more frequently. For small-molecule screens, at least 1500 embryos per experimental day are required. For microinjection experiments, two morning waves of at least 500 synchronously fertilized embryos are required. To achieve these goals, the Core made the following changes, working together with RAMB and Charles River: (1) The MEPS light cycle was adjusted to 9 am on and 11 pm off. (2) A second large MEPS was brought on line and seeded with 3000 visually curated healthy embryos derived from a wild-type EK stock (EK: Ekkwill strain) that was maximized for robustness via genetic diversity (Weinstein lab). (3) Spawning platforms are presented to these fish on Tuesdays, Wednesdays, and Thursdays at 9:00 am followed by a 9:45 am collection, and again at 9:45 am followed by a 10:45 am collection. (4) To eliminate spill-through of older embryos, a second and fully rinsed spawning platform is introduced at 9:45 am rather than re-using the first spawning platform, which had been our initial and less successful approach. (5) To facilitate embryo collection, a larger-size petri dish was introduced. Collection of MEPS embryos according to this new regime started on 8/1/16, when the breeding population was 12 weeks old. Beginning with week 15 and continuing to week 17, benchmarks were largely being achieved. Specifically more than 1500 embryos were obtained on six out of the eight collection days and more than 500 synchronous embryos were obtained on 12 out of the 16 morning collections during this period. Future work will expand this regime and implement a re-population schedule to include both the large MEPS. The plan is to repopulate the MEPS biannually and in staggered fashion (i.e., one new generation of 3000 curated embryos per quarter), such that each MEPS breeder population is used from 3 to 9 months of age.

*Automating fish size measurement.* An ever more common phenotypic characterization of genetic variants in zebrafish is the measurement of their sizes and weights and how these change over time. Key members of this class of genetic variants include zebrafish models for human diseases known to drive alterations in the size or weight of affected individuals, such as inborn errors of metabolism. Indeed, the use of the Core's macro-photography lens and milligram balance to document various lines and models has risen strikingly since the Core's creation in 2012. Recognizing this new trend and with financial assistance from the Stratakis lab, the Core contracted Viewpoint Life Sciences in August, 2014, to write software for their behavior-tracking systems designed to measure birds-eye view lengths and surface areas of free-swimming zebrafish embryos, larvae, juveniles, and adults. A promising software package was developed and installed on one of three behavioral tracking units owned by NHGRI and shared by NICHD (Figure 1). We found that up to five free-swimming juveniles or adults with a minimum length of about 1.2 cm can be reproducibly measured for snout-to-tail base length and birds-eye view surface area over the same section of their bodies. Future work will include longitudinal growth studies using R&D Aquatics' DC-96 tanks, in which 24 zebrafish can be reared in isolated chambers. R&D Aquatics has allowed the Core to pre-test a new set of baffles designed to permit isolation of fish beginning at a younger (or smaller stage); we found that juveniles of 8–10 mm of length can be successfully isolated, corresponding to approximately four weeks post fertilization for wild-type fish. In future we will also work to develop holding systems that permit smaller and younger fish to be measured across all life stages and to develop software that leverages the two orthogonal cameras on Viewpoint Life Science's 3D system to enable volumetric size measurements.

## Service

Feldman joined the NICHD Animal Care and Use Committee (ACUC) and is participating in monthly meetings and other oversight activities.



## Educational outreach

Feldman helped orchestrate 2016 'Take Your Child to Work Day' events at the Central Aquatics Facility. He also acquired a highly portable NightSea system, which can convert a high-school level microscope into a fluorescent scope, and used this to assist a teacher and her students from Sidwell Friends School in Washington DC to visualize their own fluorescent zebrafish embryos.

## Additional Funding

- NICHD Customers: \$6,750 in fee-for-use charges
- Non-NICHD Customers: \$8,200 in fee-for-use charges
- Bench-to-Bedside: \$10,000 (second year of three)

## Publications

1. Gore A, Athans B, Iben J, Johnson K, Russanova V, Castranova D, Pham V, Butler M, Williams-Simons L, Nichols J, Bresciani E, Feldman B, Kimmel C, Liu P, Weinstein B. Epigenetic regulation of hematopoiesis by DNA methylation. *eLife* 2016 5:e11813.
2. Trivellin G, Bjelobaba I, Daly AF, Larco DO, Palmeira L, Fauz FR, Thiry A, Leal LF, Rostomyan L, Quezado M, Scherthaner-Reiter MH, Janjic MM, Villa C, Wu TJ, Stojilkovic SS, Beckers A, Feldman B, Stratakis CA. Characterization of GPR101 transcript structure and expression patterns. *J Mol Endocrinol* 2016 57:97-111.
3. Feldman B. Taking the middle road: vertebrate mesoderm formation and the blastula-gastrula transition. In: Moore S., ed. *Principles of Developmental Genetics, 2nd Edition*. Academic Press 2014 203-236.
4. Horstick EJ, Jordan DC, Bergeron SA, Tabor KM, Serpe M, Feldman B, Burgess HA. Increased functional protein expression using nucleotide sequence features enriched in highly expressed genes in zebrafish. *Nucleic Acids Res* 2015 43(7):e48.

## Collaborators

- Perry Blackshear, PhD, *Signal Transduction Laboratory, NIEHS, Research Triangle Park, NC*
- Harold Burgess, PhD, *Section on Behavioral Neurogenetics, NICHD, Bethesda, MD*
- Elena Casey, PhD, *Georgetown University, Washington, DC*
- Stephen Kaler, MD, *Section on Translational Neuroscience, NICHD, Bethesda, MD*
- Forbes D. Porter, MD, PhD, *Section on Molecular Dymorphology, NICHD, Bethesda, MD*
- Thomas Sargent, PhD, *Section on Vertebrate Development, NICHD, Bethesda, MD*
- Constantine Stratakis, MD, D(med)Sci, *Section on Endocrinology and Genetics, NICHD, Bethesda, MD*
- Kandice Tanner, PhD, *Laboratory of Cell Biology, NCI, Bethesda, MD*
- Mendel Tuchman, MD, *Children's National Medical Center, Washington, DC*
- Brant Weinstein, PhD, *Section on Vertebrate Organogenesis, NICHD, Bethesda, MD*

## Contact

For more information, email [bfeldman@mail.nih.gov](mailto:bfeldman@mail.nih.gov) or visit <http://zcore.nichd.nih.gov>.

## Molecular Genomics Core Facility

With the goal of understanding genetic changes and mechanisms underlying human diseases, the Molecular Genomics Core Facility supports NICHD investigators by providing next-generation deep sequencing and project data analysis.

### Next-Generation sequencing and bioinformatics support

The Molecular Genomics Core (MGC) provides DNA and RNA sequencing services for genomic and genetic research to investigators within the NICHD. The MGC is currently operating with three sequencing machines. Most of our work is conducted on our high-capacity, production-scale machine: an Illumina HiSeq 2500. The two other sequencers, an Illumina MiSeq and an Ion Torrent Personal Genomics Machine, are smaller, faster machines, which can generate longer sequence reads. Our recently acquired cBot liquid handler will allow even higher through-put on the Illumina HiSeq. This array of sequencers provides a suite of scales and capabilities. Our sequencing services include whole genome, whole exome, targeted exome, and gene-specific DNA sequencing, as well as whole transcriptome sequencing (RNA-Seq), microRNA sequencing, microbiome sequencing, bisulfite sequencing (DNA methylome), ChIP-Seq, and ribosomal profiling.

The MGC provides significant primary data processing and downstream bioinformatic support and can assist in designing experiments or sequencing strategies (for example, optimization of targeted exome design). During the past year, the MGC provided sequencing for 42 projects across the full spectrum of sequencing types; the projects involved 19 NICHD Principal Investigators from 10 Affinity Groups. In addition to sequencing and providing our standard primary analysis of the resulting data, the MGC delivered enhanced bioinformatic support for nine NICHD investigators across six Affinity Groups. Our mission is to offer accurate and innovative sequencing and bioinformatic tools to facilitate research into the diagnosis, counseling, and treatment of hereditary disorders, and to support basic research, which promotes understanding of human health and development.



**Forbes D. Porter, MD, PhD,**  
*Director, Molecular Genomics  
Core Facility*

Steven L. Coon, PhD, *Staff Scientist*  
James R. Iben, PhD, *Staff Scientist*  
Tianwei Li, PhD, *Staff Scientist*

## Publications

1. Peng C, Yao G, Gao B-M, Fan C-X, Bian C, Wang J, Cao Y, Wen B, Zhu Y, Ruan Z, Zhao X, You X, Bai J, Li J, Lin Z, Zou S, Zhang X, Qiu Y, Chen J, Coon SL, Yang J, Chen J-S, Shi Q. High-throughput identification of novel conotoxins from the Chinese tubular cone snail (*Conus betulinus*) by multitranscriptome sequencing. *GigaScience* 2016 5:17.
2. Gore AV, Athans B, Iben JR, Johnson K, Russanova V, Castranova D, Pham VN, Butler MG, Williams-Simons L, Nichols JT, Bresciani E, Feldman B, Kimmel CB, Liu PP, Weinstein BM. Epigenetic regulation of hematopoiesis by DNA methylation. *Elife* 2016 5:e11813.
3. Gebert C, Rong Q, Jeong S, Iben J, Pfeifer K. H19ICR mediated transcriptional silencing does not require target promoter methylation. *Biochem Biophys Res Commun* 2016 476(3):121-126.
4. Arimbasseri AG, Iben J, Wei FY, Rijal K, Tomizawa K, Hafner M, Maraia RJ. Evolving specificity of tRNA 3-methyl-cytidine-32 (m3C32) modification: a subset of tRNAs<sup>Ser</sup> requires N6-isopentenylation of A37. *RNA* 2016 22(9):1400-1410.
5. Hartley SW, Mullikin JC, Klein DC, Park M, NISC Comparative Sequencing Program, Coon SL. Alternative isoform analysis of *Ttc8* expression in the rat pineal gland using a multi-platform sequencing approach reveals neural regulation. *PLoS One* 2016 11(9):e0163590.

## Collaborators

- Paul Badenhorst, PhD, *University of Birmingham, Birmingham, UK*
- Tamás Balla, MD, PhD, *Section on Molecular Signal Transduction, NICHD, Bethesda, MD*
- Harold Burgess, PhD, *Section on Behavioral Neurogenetics, NICHD, Bethesda, MD*
- Michael Cashel, MD, PhD, *Section on Molecular Regulation, NICHD, Bethesda, MD*
- David Clark, PhD, *Section on Chromatin and Gene Expression, NICHD, Bethesda, MD*
- Robert Crouch, PhD, *Section on Formation of RNA, NICHD, Bethesda, MD*
- Angela Delaney, MD, *Unit on Genetics of Puberty and Reproduction, NICHD, Bethesda, MD*
- Benjamin Feldman, PhD, *Zebrafish Core, NICHD, Bethesda, MD*
- Kenneth Fischbeck, MD, *Neurogenetics Branch, NINDS, Bethesda, MD*
- Alan Hinnebusch, PhD, *Section on Nutrient Control of Gene Expression, NICHD, Bethesda, MD*
- Henry Levin, PhD, *Section on Eukaryotic Transposable Elements, NICHD, Bethesda, MD*
- Paul Love, MD, PhD, *Section on Cellular and Developmental Biology, NICHD, Bethesda, MD*
- Todd Macfarlan, PhD, *Unit on Mammalian Epigenome Reprogramming, NICHD, Bethesda, MD*
- Richard Maraia, MD, *Section on Molecular and Cellular Biology, NICHD, Bethesda, MD*
- Joan Marini, MD, PhD, *Section on Heritable Disorders of Bone and Extracellular Matrix, NICHD, Bethesda, MD*
- Anil Mukherjee, MD, PhD, *Section on Developmental Genetics, NICHD, Bethesda, MD*
- Karl Pfeifer, PhD, *Section on Genomic Imprinting, NICHD, Bethesda, MD*
- Tracy Rouault, MD, *Section on Human Iron Metabolism, NICHD, Bethesda, MD*
- Gisela Storz, PhD, *Section on Environmental Gene Regulation, NICHD, Bethesda, MD*
- Brant Weinstein, PhD, *Section on Vertebrate Organogenesis, NICHD, Bethesda, MD*
- Erin Wolff, MD, *Unit on Reproductive and Regenerative Medicine, NICHD, Bethesda, MD*

## Contact

For more information, email [NICHDDIRMolGenomicsCore@mail.nih.gov](mailto:NICHDDIRMolGenomicsCore@mail.nih.gov) or visit <http://mgl.nichd.nih.gov>.

## Microscopy and Imaging Core

The mission of the NICHD Microscopy and Imaging Core (MIC) is to provide service in three different areas: 1) wide-field and confocal light microscopy, 2) transmission electron microscopy, and 3) sample preparation for light and electron microscopy. Following the retirement of James Russell in April 2016, Vincent Schram now serves as executive director under the management of Chris McBain. Tamás Balla acts as scientific advisor for the facility.

Located on the ground floor of The Porter Neuroscience Research Center, Building 35A, on the NIH campus, the facility is accessible 24/7, and users can reserve time on each microscope by using an online calendar. Vincent Schram, the point person for light and confocal microscopy, works in close collaboration with his NINDS counterpart, Carolyn Smith, who manages the Light Imaging Facility, also located in the Porter Neuroscience building. This mode of operation is highly beneficial as it provides extended support hours, wider expertise, and access to more equipment than each Institute alone could afford.

### Mode of operation

The MIC is available free of charge to all NICHD investigators and, resources permitting, to anyone within the Porter Neuroscience building. For every new project, MIC staff meet with the Principal Investigator and postdoctoral scientists involved in the study to discuss the background and goals of the project and to define its most appropriate techniques and instrumentation.

For light microscopy, sample preparation and image acquisition are typically handled by users, with support and training provided by Lynne Holtzclaw (specimen preparation) and Dr. Schram (imaging and data analysis). For electron microscopy (EM), most of the sample processing and imaging is done in-house by Chip Dye and Ms. Holtzclaw to ensure consistent and reproducible conditions.

### Light microscopy

Three modern laser confocal microscopes are available in the facility: a Zeiss LSM 780 equipped for spectral imaging of live and fixed specimens that require high sensitivity and resolution; a Zeiss



**Vincent Schram, PhD, Staff Scientist**

Louis (Chip) Dye, BS, *Research Assistant*

Lynne A. Holtzclaw, BS, *Research Assistant*

710 inverted for high-resolution confocal imaging; and a hybrid Nikon spinning disk/TIRF (total internal reflection fluorescence) microscope with super-resolution capabilities. A modern two-photon platform, slated for delivery in January 2017, will permit imaging of thick tissue sections, live animals, and large cleared specimens. We also have access to the NINDS Zeiss 880, a unique instrument equipped with a super-resolution (“Airy”) detector, which has been used with great success for studies of neuronal spines, neuromuscular junctions, and other sub-cellular organelles. In addition to these high-end instruments, three wide-field fluorescence microscopes and a stereo microscope are available. Incubation is fully supported on all confocals with temperature, CO<sub>2</sub>, and humidity control.

Each user receives counseling on specimen preparation and staining, and, when necessary, one-on-one coaching in sample preparation is provided in the facility’s lab space. Once their specimen is ready, users receive an initial training session on the light microscope required for the project, followed by periodic refreshers at the user’s request or when the staff feel that the equipment is not being used properly.

For data analysis, the MIC provides training and support on several image-processing options: Zeiss Zen, Nikon Elements, Imaris, Metamorph, and ImageJ. The programs are available in the facility on high-end workstations. When required, custom solutions are developed to fill particular needs, such as large-volume image analysis.

## Electron microscopy

Typically, all EM processing (fixation, embedding, sectioning, and staining) is done in-house by Mr. Dye and Ms. Holtzclaw. The MIC maintains and operates a fully equipped EM laboratory with an LKB Pyramitome, a Leica CM3050-S cryostat, and a Reichert Ultracut-E ultramicrotome. A new Leica EM UC7 ultra-microtome with cryo-sectioning capabilities was recently purchased to extend cryo-EM capabilities. Cryo-EM preserves a high level of immuno-reactivity and permits imaging of specimens in a near-native state. The technique has been requested by several investigators, and the facility is actively moving onto this field. EM imaging is conducted mostly by Mr. Dye on a JEOL TEM 1400 series electron microscope, a cryo-EM-compatible instrument.

## Additional support and capabilities

Overseen by Ms. Holtzclaw, the MIC provides additional resources such as tissue-culture and preparative space, vibratomes for live and fixed tissues, and a perfusion-fixation platform. On-site equipment demonstrations from vendors are held frequently and provide a valuable platform for the larger NIH community to evaluate new products and instrumentation in the field of microscopy. The MIC also provides a yearly training course offering an integrated approach, from sample preparation to imaging and data analysis. This week-long event is held each May. The staff also volunteer time to teach sample preparation and image analysis in NIH’s FAES (Foundation for Advanced Education in the Sciences) Biotech 35 course.

## Facility usage

Since the facility moved from building 49 to the new part of the Porter Neuroscience building, usage has increased significantly and continues to rise each quarter, to some extent because tenants of building 35 take advantage of the facility’s open-door policy (mostly NINDS investigators), but the Institute’s own usage is also rising. As of November 2016, all three confocal instruments (the Zeiss 710 and 780, and the Nikon spinning disk) have been used on average 40 hours per week over the past 12 months.

Since its inception in 2004, the work carried out in the MIC has been included in more than 180 publications. For a complete list, go to: <https://science.nichd.nih.gov/confluence/display/mic/Publications>

## Collaborators

- Carolyn L. Smith, PhD, *Developmental Biology Section, NINDS, Bethesda, MD*

## Contact

For more information, email [schramv@mail.nih.gov](mailto:schramv@mail.nih.gov) or visit <http://mic.nichd.nih.gov>.

## Research Informatics Support for NICHD's Division of Intramural Research

The Computer Support Services Core (CSSC) provides informatics and research services to intramural investigators at NICHD in four key areas: clinical informatics, bioinformatics, biovisualization web services, and core IT support.

During the past year, the team completed a major hardware upgrade of all its infrastructure, greatly increasing storage capacity and computing resources.

### Clinical informatics

The CSSC continued to support and develop applications related to clinical and translational medicine, including the Clinical Trials Database (CTDB) project. Such informatics tools allow researchers to design, collect, and report clinical observations related to natural history and interval-based studies. The total number of protocols and research projects supported by the CTDB team increased to approximately 454 for 14 NIH institutes, with an expansion of research questions to over 185,000. The software development group completed two releases that included features for the Form Data Download, Electronic Regulatory Binder improvement, and various performance enhancements. We supported the Clinical Trial Survey System (CTSS), an application for patient surveys, now used for 151 protocols. The Clinical Datamart provides lab results, vitals, and medications; and ECG/EKG datamarts were upgraded to support new protocols. The database team worked on approximately 600 reports during the year; moreover the team has been consolidating the CTDB project-reporting tools.

### Biological visualization web services

The CSSC team provides laboratories of NICHD's Division of Intramural Research (DIR) with scientific communication and media services, including publication support, website and content management support, audio/visual production, image-processing services and consulting, bio-medical graphics, 3D printing, and print media pre-production. During the past year, we updated all the Principal Investigators' (PI) websites within a standardized NICHD template. We provided input and support to the NIH Library's Technology Sandbox in its effort to provide direct 3D printing



**David Songco**, *Head, Computer Support Services Core*  
 Marco Crosby, *Program Engineer*  
 John Czapary, BS, *Laboratory Technical Manager*  
 Michelle Duverneau, *IT Specialist*  
 Nareg Bakirci, *Contractor*  
 Matt Breymaier, *Contractor*  
 Raquel Gray, *Contractor*  
 Audrey Harrell, *Contractor*  
 Asma Idriss, *Contractor*  
 Sean Ivusic, *Contractor*  
 Izabella Kachikyan, *Contractor*  
 Joelle Khoriaty, *Contractor*  
 Kesa Koresko, *Contractor*  
 Tamara Prodanov, *Contractor*  
 Patricia Pullen, *Contractor*  
 Nadine Skaff, *Contractor*  
 Jeremy Swan, *Contractor*  
 Nichole Swan, *Contractor*  
 Angela Tilghman, *Contractor*  
 George Tran, *Contractor*  
 Loc Vu, *Contractor*

capabilities to all NIH staff, and we are now working to facilitate the use of Virtual and Augmented Reality (VAR) at the NIH Library and at the NIH in general through a new scientific interest group (VARIG).

The web activities of the DIR web services program include: laboratory websites, the annual report, and internet applications. The CSSC continued to maintain approximately 139 public DIR websites, while reducing the number and footprint of web properties, as well as implementing a redesign effort by adapting 60 websites into a content-management system under a standardized design template.

The bioviz team created several illustrations for publications and journal covers on behalf of NICHD scientists. We provided research video support, authoring time-lapse videos, assisting in the digitization and storage of 25,000 videos, and recording audio/video for the Adult and Pediatric Endocrinology Training Programs. In addition, we provided photography, design and printing support for the DIR Annual Fellows and PI Retreats. We provided a Virtual Reality demo for the NIH Research Festival, including creating and printing informational materials. We provided poster and flier design, printing, and distributing to advertise the NICHD Director's Exchange series. The team continued graphic design support and authored several articles for the NICHD Connection, a monthly newsletter for Intramural research fellows. The Science wiki allows PIs to maintain a customized web presence, share lab protocols and scientific data, and recruit fellows.

## Bioinformatics

The CSSC works with the scientific community in NICHD's DIR to create and manage web applications supporting research publications and the dissemination of information within the community. For example, the CSSC runs several applications that facilitate sharing and searching of genomic data from mutations to gene expression. The bioinformatics team assisted the Molecular Genomics Core in the maintenance of related applications. A high-performance computing (HPC) cluster was set up to assist with genomics computational requirements. The genomics workbench Galaxy was installed and configured on the HPC to take advantage of parallel processing capabilities. The CSSC also continues to provide and manage dozens of terabytes of storage to support genomic research.

*Custom software development for scientific and administrative support.* This aspect of support includes software applications for DIR services. For example, we continued to enhance the Manuscript Tracking System (MTrac), a web-based application that automates the clearance and approval process for manuscripts in the DIR. The system now includes a web service feature to connect to NLM PubMed and File Transfer Process (FTP) connections to PubMed Central to allow PIs to comply with NIH's Public Access policies. The team successfully launched the Fellows Annual Progress Report for the DIR. The module helps facilitate a strong relationship between mentor and fellow while granting the Office of Education invaluable feedback on the training program. The team completed five production releases, including users' support for all DIR programs. The CSSC maintained the Cost Tracker module for the DIR, enabling the capture, organization, and reporting of various expenses on a per-protocol basis. The CSSC continue to work closely with the Office of the Clinical Director to develop a model for protocol cost vs. effectiveness and a protocol cost estimator questionnaire.

## Core IT services

The CSSC continued to expand its services to the DIR community in core IT areas.



*Network and desktop services.* We support reliable, secure, and efficient information technology solutions, which includes acquisition, maintenance, and support for licensed software used by the DIR research community, e.g., EndNote/Reference Manager, Bookends, GraphPad Prism, PyMol, network services (email, data backups, VPN, helix, PDAs, wireless configurations); and crossplatform desktop, server, and application hosting in the Rockledge Data Center. We host software licenses for computation, 3D imaging, and sequencing, e.g., Amira, ArrayStar and QSeq, Autodesk Maya, DNASTAR Lasergene Core Suite, MathWorks, MATLAB, MolSoft, and SeqMan NGen. This year, MATLAB Distributed Computing Server, software and hardware (128GB, 16 Worker), was added. Hosting these licenses permits users to leverage their research with additional tools available on Helix and Biowulf. We also assist users in identifying, researching, and purchasing custom hardware configurations to match research instrument requirements.

*Data-recovery services.* We implemented core data-recovery tools for all media, hard drive, SSD, and flash, etc., including RAID 0 and 5 recovery tools. Since 2005, the Core has recovered over a terabyte of research data from failed drives and media.

## Additional Funding

- The Clinical Trials Database (CTDB) project receives funding from other NIH Intramural Institute or Center programs, including NINR, NIMH, NIDCR, NIEHS, NIAMS, NINDS, CC, NHLBI, NIAAA, NHGRI, NCCIH and NIDDK.

## Collaborators

- Karel Pacak, MD, PhD, DSc, *Section on Medical Neuroendocrinology, NICHD, Bethesda, MD*
- Forbes D. Porter, MD, PhD, *Clinical Director, NICHD, Bethesda, MD*
- Leorey Saligan, PhD, RN, CRNP, *Deputy Clinical Director, NINR, Bethesda, MD*
- Peter Schmidt, MD, *Behavioral Endocrinology Branch, NIMH, Bethesda, MD*
- Steven Stanhope, PhD, *University of Delaware, Newark, DE*
- Constantine Stratakis, MD, D(med)Sci, *Scientific Director, Division of Intramural Research, NICHD, Bethesda, MD, NICHD, Bethesda, MD*
- Susan Swedo, MD, *Pediatrics and Developmental Neuroscience Branch, NIMH, Bethesda, MD*
- Jack Yanovski, MD, PhD, *Section on Growth and Obesity, NICHD, Bethesda, MD*

## Contact

For more information, email [songcod@mail.nih.gov](mailto:songcod@mail.nih.gov).

## Affinity Groups

---

Scientists and physicians in the NICHD Division of Intramural Research (DIR) are organized into 14 affinity groups (AGs). Each AG is an intellectual hub for a group of investigators, creating a forum to share ideas and collaborate around common themes in support of the DIR mission.

The AGs serve as catalysts for new initiatives. Each investigator has a primary affiliation with an AG most closely aligned with his or her scientific interests. Secondary affiliations allow for communication across specialties in support of translational research and new collaborations.

Each AG has its own mission statement, shared research goals and objectives, and resources. Collectively, the AGs contribute to recruitment, mentoring, and the annual DIR scientific retreat.

### Aquatic Models of Human Development

The **Aquatic Models of Human Development Group** uses zebrafish as a model vertebrate organism to study human development. We exploit the advantages of the zebrafish model for genetic screens, genomic manipulation, microscopic imaging, and cell and behavioral biology to gain insights into mechanisms controlling human development and defects therein that can result in disease. By maintaining a high level of expertise and resources, the group lowers the barrier to entry for other researchers in the intramural program for use of zebrafish as a research tool for investigating biological processes *in vivo*. The five PIs and the Zebrafish Core Facility, along with approximately 30 postdocs, doctoral trainees and technical staff, all focusing on zebrafish as a model system and all working in the Building 6 complex, create a critical mass of talent unsurpassed at NIH.

The group specializes in the generation of induced and engineered mutations and transgenic zebrafish lines that are used to study *in vivo* the function and integration of regulatory factors and pathways that are critical to the development, health, and survival of vertebrates, including humans. Extensive formal collaborations and informal interactions between group members promote the exchange of reagents and technical information to ensure that NICHD researchers remain at the cutting edge of zebrafish research worldwide.

Harold Burgess  
Ajay Chitnis

Igor Dawid  
Ben Feldman (Core)

Tom Sargent  
Brant Weinstein

---

### Basic Mechanisms of Genome Regulation

The mission of the **Basic Mechanisms of Genome Regulation Group** is to do basic research into the molecular mechanisms of fundamental processes ubiquitous to all cells. Such research inevitably results in new knowledge that impacts our understanding of both health and disease. The members of the BMGR group have a strong history of producing knowledge-changing advances in several fundamental processes essential to life: DNA replication, DNA repair, nucleotide metabolism, RNA biogenesis and metabolism, chromatin-mediated control of gene expression, and genome integrity. Simply put, the BMGR group is a unique collection of world experts in processes involving DNA and RNA metabolism and the consequences of alterations of

these processes to cells and organisms. Recent advances from work by BMGR members, as well as others, has revealed that although these processes are ubiquitous, defects in them are often manifested as specific health disorders with distinctive deficiencies in development and with tissue-specificity, or in cancer. Inherent to the mission is to increase understanding of how natural genetic diversity in a population contributes to these fundamental processes in ways that affect disease and to apply such knowledge so that specific strategies for improving health can be developed.

The vision is to elucidate new knowledge about fundamental processes that will promote the discovery of novel strategies for treatment and prevention alternatives across a multitude of diseases that share involvement of altered nucleic acid metabolism, gene expression, and genome integrity. Through basic research that incorporates modern advances in biochemistry, genetics, and genomics, the BMGR group will continue to generate new knowledge relevant to the fundamental processes essential to growth, development, and health.

The BMGR group vision includes the promotion of collaborations and communication that support its mission. This group has the ability to discover fundamental aspects of growth and development from multifaceted perspectives and disciplines and to investigate how disturbances in one process can affect another. Because our interests are not principally focused on any particular disorder, they extend beyond the tissue-specific gene expression aspects of animal development and provide unique perspectives into growth, development, and disease. Indeed, different defects in a single process can be manifested as different diseases. Given the NIH's penchant for high-risk endeavors, the BMGR group and the many collaborations among its member foster a greater depth and breadth of fundamental discovery than would exist in its absence.

Mike Cashel  
David Clark

Bob Crouch  
Melvin DePamphilis

Richard Maraia  
Roger Woodgate

---

## Behavioral Determinants and Developmental Imaging

The mission and vision of the **Behavioral Determinants and Developmental Imaging Group** is to understand determinants of behavior and behavioral changes occurring during development using its unique nonhuman primate (NHP) and normative and clinical populations. Novel *in vivo* structural and functional imaging methods will be developed and applied to provide correlative information to assist in addressing these processes and potentially provide translational methods for assessing salient changes in the developing brain. In collaboration with the Perinatal and Obstetrical Group, we plan to develop new imaging tools to scan pregnant mothers and children from the fetal period to young adulthood and to coordinate resulting insights in brain development with parallel studies of the ontogeny of cognition, emotion, and behavior. With the Neurosciences Group, we plan to study possible neuroanatomical sequelae of plasticity and learning in these populations.

We seek greater understanding in the identification of quantitative *in vivo* imaging biomarkers for salient functional or structural changes in the brain associated with cognitive and emotional behavior or cognitive changes or abnormalities that could be used clinically or as enabling technologies in the neurosciences. We

also seek to better integrate and correlate imaging (i.e., radiological) changes in the developing brain and gene expression changes in human and NHP populations.

Peter Basser  
Marc Bornstein

Amir Gandjbakhche  
Leonid Margolis

Stephen Suomi

---

## Bone and Matrix Biology in Development and Disease

Matrix biology is central to the NICHD mission because it is intrinsic to the formation and reshaping of tissues before and after birth. This group aims to elucidate the mechanisms by which primary gene defects cause skeletal fragility and other matrix disorders and to apply this knowledge to the treatment of affected children. This goal is pursued with a close relationship between basic, translational, and clinical science.

The current primary focus of the group is on translational studies of skeletal dysplasias and related bone disorders. We have identified and characterized molecular mechanisms of several novel skeletal development disorders in this spectrum. In addition to building on these successes and expanding our knowledge of mechanisms and pathology of skeletal development, we are developing novel approaches to therapeutic intervention, which will be translated to clinical trials. We are expanding our research to extracellular matrix (ECM) development and pathology in other tissues and organs. We also anticipate expanding our research program toward studies of ECM disorders in placenta, cartilage, growth plate, and other tissues and organs that are involved in fetal health, prematurity, and early child growth and development.

Sergey Leikin

Joan Marini

---

## Cell and Structural Biology

The **Cell and Structural Biology Group (CSBG)** conducts basic research on the molecular mechanisms that underlie fundamental cellular processes, such as organelle biogenesis and function, regulation of cell metabolism by small RNAs, small proteins, post-translational modifications and developmental programs, host-pathogen interactions, and the structure, traffic, and function of signaling proteins in the central nervous system. Knowledge gained from these studies is applied to the elucidation of the pathogenesis of various diseases, including neurodevelopmental, behavioral, and neurodegenerative disorders, metabolic disorders, and infectious diseases.

The CSBG has outstanding facilities for microscopic imaging of cell structure and function and for recombinant protein production in multiple prokaryotic and eukaryotic expression systems for X-ray crystallographic and biochemical analyses. In addition, the group has expertise in generating targeted mutations in rodents and in the anatomical, neurochemical, electrophysiological, and behavioral analyses of the mutant animals.

Anirban Banerjee  
Juan Bonifacino  
Andres Buonanno

Mary Lilly  
Jennifer Lippincott-Schwartz  
Matthias Machner

Gisela Storz

## Cell Regulation and Development

The mission and vision of the **Cell Regulation and Development Group** is to increase fundamental knowledge of basic molecular mechanisms of cell biology and animal development and to enhance understanding of how dysregulation of these processes contributes to human disability and disease.

By combining expertise in the genetics of model organisms (including transgenic and null mouse models), cell biology, biochemistry, molecular biology, biophysics, and enzymology, members of the group advance individual research objectives by regularly providing insights and advice to one another and through collaborations enabling synergy in research methods and experimental approaches. These interactions have engendered the development of novel technologies and strategies that will facilitate future discoveries in the areas of molecular mechanisms of synaptic circuit assembly and function, the mechanisms and regulation of protein synthesis and transcriptional activation, the functions and regulation of GRTH/DDX25 in spermatogenesis, the role of signaling pathways in transcriptional control of LH and Prolactin receptors, the identification of molecular markers for diagnosing and treating prostate diseases, technologies based on transposable elements and deep sequencing for genome-wide profiles of gene function, the role of transposable elements in reorganizing the host genome in response to stress, and the mechanisms governing adult organ formation during postembryonic vertebrate development.

Mary Dasso  
Tom Dever  
Maria Dufau  
Alan Hinnebusch

Chi-Hon Lee  
Henry Levin  
Jon Lorsch  
Ida Owens

Mihaela Serpe  
Yun-Bo Shi

---

## Developmental Endocrine Oncology and Genetics

The mission and vision of the **Developmental Endocrine Oncology and Genetics Group** is to 1) establish new and improved methods, strategies, technologies, and algorithms for the diagnosis, localization, and management of various endocrine tumors, 2) explain the molecular basis for different clinical presentations and establish pathways of tumorigenesis for these tumors, 3) search for new molecular, genetic, proteomic, and metabolomic markers for the development of better diagnosis and localization and seek novel targets for the treatment of metastatic endocrine tumors and biomarkers for predicting responses to therapies, 4) facilitate the implementation of newly available diagnostic techniques and treatment options, including the initiation of new clinical trials, 5) facilitate new and improved intramural, national, and international collaborations, interdisciplinary studies, and team approaches, and 6) facilitate the establishment of national and international databases/networks and train physician-scientists in endocrine tumors.

Peter Backlund (Core)  
Maya Lodish (Training)

Karel Pacak  
Constantine Stratakis

---

## Genetics and Epigenetics of Development

The mission of the **Genetics and Epigenetics of Development Group** is to research the genetic and

epigenetic mechanisms that control reproduction, embryogenesis, and organ system development. Our vision is to apply the knowledge gained to enhance human health.

Judy Kassis  
Jim Kennison

Paul Love  
Todd Macfarlan

Keiko Ozato  
Karl Pfeifer

---

## Integrative Membrane, Cell, and Tissue Pathophysiology

Human development, on which the future child's health depends, is a complex phenomenon within the female starting with egg-spermatozoa fusion. In each individual, a plethora of molecular recognition events mediate the development of an immune system to defend against pathogens, a musculoskeletal system to maintain the body, and flexible networks of molecular expression to manage environmental stress. Traditionally, studies of these processes are divided into biochemistry, cell biology, virology, toxicology, etc. However, nature does not know these artificial divisions, and new understandings emerge from the crucible that interfaces mathematically minded physical scientists with biomedical researchers. The **Integrative Membrane, Cell, and Tissue Pathophysiology Group** is a unique scientific body that approaches human development in normal life and pathology as an integral process and encompasses first-class cell biologists, physical chemists, biophysicists, virologists, and immunologists who not only successfully train postdocs and students within their own fields, but widely collaborate, building and uniquely promulgating multidisciplinary approaches to the most important biomedical problems in the framework of the NICHD mission.

By choosing carefully which biophysical projects really answer the fundamental problems that limit advancement in medicine, we as a group will suffuse these identified problems with our basic wisdom of biophysics. This wisdom includes a deep knowledge of polymer physics, membrane biology and virology, inter- and intracellular communication, the theory of transporters and diffusion of domains, the physics of channel permeation and protein conformational change, the physical chemistry of membrane hydration forces and recognition, the physiology of cell signaling and receptor activation, lipid/protein interactions, and the physiology of secretion, viral infection, parasite invasion, fertilization, adipose transporter trafficking and insulin signaling, and developmental cell fusion. Our strategy is to sharpen our techniques and power of observation to prove our discoveries, including proteomic architecture of signaling complexes and cellular structures, TIRF microscopy, long-term live-cell time-lapse imaging of tissue and cultured cells, confocal and two-photon scanning microscopy, electrophysiology, physical theories to devise experimental tests of hypotheses, cryoelectron microscopy, and lipidomic analyses.

We are now in a position to tackle the developmental changes seen in obesity and genetic disorders, the pathophysiology of influenza, dengue, and HIV viral infection and assembly, a 3D immunohistochemical microscopy of normal and compromised placenta at super-resolution levels, the use of human brain culture in dissociated and slice culture to study traumatic brain injury and glioblastomal neoplasia, membrane domain organization, regulation of mitochondrial metabolism by cytosolic proteins, and muscle molecular ultrastructure. We currently anticipate testing if hydrogen bond theory can explain hydration repulsion of DNA and membranes, developing a deeper understanding of mechanical, electrical, and chemical interactions in complex, multicomponent cell communities, achieving the conceptual integration of cutting-

edge immunological information and assays for cell-cell communication in the onset of tissue pathology and discovering the role and mechanisms of microRNA vehicles in serum.

Sergey Bezrukov  
Leonid Chernomordik

Alexander Sodt  
Stanko Stojilkovic

Joshua Zimmerberg

---

## Metals Biology and Molecular Medicine

The mission and vision of the **Metals Biology and Molecular Medicine Group** is to continue our current research in the areas of metal biology and implications for pathophysiology and treatment of human diseases, including gene therapy. There is much synergy to be gained by comparing mechanisms for maintenance of iron and copper homeostasis.

Stephen Kaler

Tracey Rouault

---

## Neurosciences

Understanding the structure and function of the nervous system is a prerequisite for predicting and treating neuropathologies. Our group uses a variety of preparations, including animal models and human tissue, and a variety of techniques to study the biology of development and function of the nervous system and underlying basic biological processes in both health and disease.

Tamás Balla  
Douglas Fields

Dax Hoffman  
Y. Peng Loh

Chris McBain  
Mark Stopfer

---

## Pediatric Endocrinology, Metabolism, and Molecular Genetics

The mission of the **Pediatric Endocrinology, Metabolism, and Molecular Genetics Group** is to advance our understanding of endocrine, genetic, and metabolic disorders that impair human development, causing disease and disability. The research in this group encompasses basic, translational, and clinical science to elucidate the etiology of these diseases and to develop new diagnostic and therapeutic approaches.

Jeff Baron  
Janice Chou

Angela Delaney  
Anil Mukherjee

Forbes Porter  
Jack Yanovski

---

## Perinatal and Obstetrical Research

The mission and vision of the **Perinatal and Obstetrical Research Group** is to 1) conduct clinical and translational research to elucidate mechanisms of disease responsible for pregnancy complications and to develop diagnostic, prognostic, therapeutic, and preventive strategies to reduce adverse pregnancy outcome and

2) train physicians and scientists in the areas of obstetrics and perinatal medicine.

Research within this group aims to 1) determine if vaginal progesterone can reduce the rate of preterm birth in twin gestations, 2) develop a method to examine the fetal heart and improve the detection of congenital heart disease before birth, 3) characterize the changes in cervical length during pregnancy (longitudinal study) and determine the risk of these changes, 4) characterize fetal growth based on fetal biometry using an individualized approach, 5) determine the frequency and clinical significance of placental pathology lesions, 6) determine the frequency and clinical significance of sterile intra-amniotic inflammation in preterm, and 7) identify biomarkers for the prediction of the “great obstetrical syndromes” (preterm labor, preeclampsia, fetal death, intrauterine growth restriction, etc.) using discovery and targeted approaches.

Roberto Romero

---

## Reproductive Endocrine and Gynecology

The **Reproductive Endocrine and Gynecology Group** consists of the primary NICHD investigators who carry out research and clinical care in women’s health. Our mission is to conduct innovative translational research and provide direct patient care in reproductive endocrinology and gynecology. Consultative services are provided to all NIH institutes.

Alan DeCherney (Training)



## Phosphoinositide Messengers in Cellular Signaling and Trafficking

We investigate signal transduction pathways that mediate the actions of hormones, growth factors, and neurotransmitters in mammalian cells, with special emphasis on the role of phosphoinositide-derived messengers. Phosphoinositides constitute a small fraction of the cellular phospholipids but play critical roles in the regulation of many signaling protein complexes, which assemble on the surface of cellular membranes and are intracellular lipid messengers controlling a variety of cellular functions. Phosphoinositides regulate protein kinases and GTP-binding proteins as well as membrane transporters, including ion channels, thereby controlling many cellular processes such as proliferation, apoptosis, metabolism, cell migration, and differentiation. We focus on the phosphatidylinositol 4 (PtdIns4)-kinases (PI4Ks), a family of enzymes that catalyze the first committed step in polyphosphoinositide synthesis. Current work aims to: (1) understand the function and regulation of several PI4Ks involved in the control of cellular signaling and trafficking pathways; (2) find specific inhibitors for the individual PI4Ks; (3) define the molecular basis of phosphatidylinositol 4-phosphate (PtdIns4P)-regulated pathways through identification of PtdIns4P-interacting molecules; (4) develop tools to analyze inositol lipid dynamics in live cells; and (5) determine the importance of the lipid-protein interactions in the activation of cellular responses by G protein-coupled receptors and receptor tyrosine kinases.

### Control of phosphatidylserine metabolism by phosphatidylinositol 4-phosphate cycling

We discovered that phosphatidylinositol 4-kinase alpha (PI4KA), one of the lipid kinases that phosphorylate the important lipid phosphatidylinositol (PI) at the plasma membrane (PM), is essential for the transport and synthesis of a critical structural lipid, phosphatidylserine (PS). Prolonged (24–36 hours) treatment of cells with a PI4KA-specific inhibitor caused a 50% reduction in cellular PS content, and the inhibitor acutely blocked PS synthesis. We demonstrated that the inhibition was not attributable to a direct effect on the PS-synthesizing enzymes but was the result of a transport defect impeding transport of PS out of its site of synthesis in the endoplasmic reticulum (ER) to the PM. Given that PS synthesis is under very strong feed-back inhibition, PS transport defects out of the ER



**Tamás Balla, MD, PhD, Head,**  
*Section on Molecular Signal  
Transduction*

Yeun Ju Kim, PhD, *Staff Scientist*

Alejandro Alvarez-Prats, PhD,  
*Postdoctoral Fellow*

Takashi Baba, PhD, *Postdoctoral  
Fellow*

Joshua Pemberton, PhD,  
*Postdoctoral Fellow*

Nivedita Sengupta, PhD,  
*Postdoctoral Fellow*

Mira Sohn, PhD, *Postdoctoral  
Fellow*

Dániel Tóth, MD, PhD,  
*Postdoctoral Fellow*

Ljubisa Vitkovic, PhD, *Special  
Volunteer*

Elisa Arthofer, MS, *Graduate  
Student*

lead to inhibition of PS synthesis. A recent study identified mutations in the PS-synthetic enzyme PSS1, which rendered the enzyme insensitive to PS-mediated feed-back inhibition. The PSS1 mutations were found to be the cause of Lenz-Majewski syndrome (LMS), a rare human disease. We found that mutant PSS1 enzymes not only raised PS to a very high level but also reduced PtdIns4P levels in several membrane compartments, including the Golgi and PM. This was owing to the activation of the PtdIns4P phosphatase enzyme in the ER by accumulating PS. We postulated the existence of a mechanism that transports PS from the ER to the PM using the energy of a PtdIns4P gradient generated between the PM and the ER. The PtdIns4P gradient is maintained by PI4KA in the PM and the Sac1 phosphatase in the ER. While our studies were in progress, a paper was published showing that oxysterol binding protein-related proteins 5 and 8 (ORP5 and ORP8) are able to transport PS from the ER to the PM using the PtdIns4P gradient set up between the PM and the ER. Indeed, we showed that ORP8 bridges the ER and the PM in contact sites and that its PM binding requires PM PtdIns4P. These discoveries have important implications given that PI4KA is an essential host protein that supports hepatitis C virus (HCV) replication in the liver. It is likely that the important role of PI4KA in PS metabolism is critical for the HCV lifecycle. The studies also contributed to our understanding of how single mutations in the PSS1 enzyme cause the pleiotropic developmental defects described in patients of Lenz-Majewski syndrome.

## Importance of the phospholipid exchange between the ER and plasma membrane and its impairment in some forms of Lou-Gehrig's disease

In this set of studies, we investigated the impact of mutations in the ER-localized VAP-B protein (vesicle-associated membrane protein-associated protein B) identified in familial forms of amyotrophic lateral sclerosis (ALS or Lou-Gehrig's disease) on the distribution and function of phospholipid transport between the ER and PM. Phospholipase C (PLC)-mediated hydrolysis of the limited pool of PM phosphatidylinositol 4,5-bisphosphate [PtdIns(4,5)P<sub>2</sub>] requires replenishment from a larger pool of phosphatidylinositol (PI) via sequential phosphorylation by PI 4-kinases and PIP 5-kinases. Given that PI is synthesized in the ER and PtdIns(4,5)P<sub>2</sub> is generated in the PM, PI transfer proteins (PITPs) are believed to mediate this lipid transfer function. Recent studies identified the large PITP protein Nir2 as important for PtdIns transfer from the ER to the PM. In a previous study, we found that Nir2 was also required for the transfer of phosphatidic acid (PA) from the PM to the ER. In Nir2-depleted cells, activation of PLC leads to PA accumulation in the PM, and PI synthesis becomes severely impaired. In quiescent cells, Nir2 is localized to the ER via an interaction through its FFAT domain [two phenylalanines (FF) in an acidic tract] with ER-bound VAP-A and VAP-B proteins. After PLC activation, Nir2 also binds to the PM via interaction of its C-terminal domains with diacylglycerol and PA. Through these interactions, Nir2 functions in ER-PM contact zones. We found that mutations in VAP-B, which were identified in familial forms of ALS (Lou-Gehrig's disease), caused aggregation of the VAP-B protein, which then impaired its binding to several proteins, including Nir2. However, the two mutations P56S and T46I did not cause a defect of similar severity. While the P56S mutation completely prevented association of VAP-B with Nir2, the T46I mutation was less severe so that Nir2 association was still supported, as were Nir2 translocation responses after PLC activation, although to a significantly lesser extent than was the case with the wild-type protein. The findings shed new light on the importance of non-vesicular lipid transfer of PI and PA in ER-PM contact zones and suggest that mutations in the VAP-B protein negatively affect this important homeostatic mechanism, possibly contributing to the progression of the devastating human disease ALS.

## Determination of the structural basis of PI4KB and ACBD3 protein interaction important for viral replication

In collaboration with the group of Evžen Boura, we investigated the structural features of the interaction

between PI4KB (one of the four PI4-kinase enzymes that can phosphorylate PI) and the ACBD3 (acyl-CoA binding domain-containing 3) protein, a protein involved in the maintenance of Golgi structure and function. PI4KB and ACBD3 proteins were both found to be important host factors for the replication of several enteroviruses in mammalian cells. It appears that the interaction of the two proteins is essential for the viral life cycle because the virus uses ACBD3 to recruit the lipid kinase to the replication organelle. Boura's group identified the minimum interaction domains between the two proteins and solved the structure of this complex. The studies identified key residues on both proteins essential for the interaction. Our group used mutant ACBD3 proteins in intact cells to demonstrate that the residues are indeed essential for the ACBD3 protein to recruit the kinase to specific membrane compartments. The structural studies could help identify pharmacological means to interrupt this association as a way of blocking enteroviral replication in mammalian cells.

## New tools for the detection of inositide-based messengers in cell populations

This year we also collaborated with our long-standing collaborator, Péter Várnai, to develop a method by which the level of inositol 1,4,5-trisphosphate (InsP3) can be followed in cell populations or in single living cells. For this we used the InsP3-binding domain of the type-I InsP3 receptor and introduced mutations to fine-tune its affinity for optimal on-off kinetics of InsP3 binding. These optimal sensors were then engineered as molecular sensors based on fluorescent resonance energy transfer (FRET) or bioluminescence resonance energy transfer (BRET) principles for single-cell or cell-population measurements, respectively. In addition to these sensors for measuring the soluble messenger InsP3, we also worked on methods, using BRET analysis, to follow inositol lipid changes in various intracellular domains. First, the Várnai group created BRET sensors for detecting PtdIns4P, PtdIns4,5P2 (phosphatidylinositol 4,5-bisphosphate), and PtdIns3,4,5P3 (phosphatidylinositol 3,4,5-trisphosphate) changes exclusively in the PM. The sensors were based on our previously characterized lipid-binding domains fused to *Renilla* luciferase and a PM-targeted yellow fluorescent protein called Venus expressed from a single plasmid, using the T2 viral sequence for separate expression of the two fusion proteins. We also generated tools based on the same principles for following phosphatidylserine (PS), phosphatidic acid (PA), diacylglycerol (DG), and cholesterol. We also made a tool-set for the detection of PtdIns4P in endosomal membranes. The new tools will be of great value in studies in which InsP3 and lipid changes need to be assessed in living cells, and they can be easily adapted for high-throughput screening applications.

## VEGF signaling in astrocytes

The spatial organization of vascular endothelial growth factor (VEGF) signaling is a key determinant of vascular patterning during development and tissue repair. How VEGF signaling becomes spatially restricted and the role of VEGF secreting astrocytes in this process remains poorly understood. We developed a green fluorescent protein (GFP)-fused VEGF that is biologically active and is capable of indicating where and how VEGF is secreted from the cells. In collaboration with Jozef Kiss, we used the VEGF-GFP fusion protein to observe the intracellular routing, secretion, and immobilization of VEGF in scratch-activated living astrocytes, using confocal time-lapse microscopy. We found that VEGF is directly transported to cell-extracellular matrix attachment sites, where it is incorporated into fibronectin fibrils. VEGF accumulated at  $\beta$ 1 integrin-containing fibrillar adhesions and was translocated along the cell surface prior to internalization and degradation. We also found that only the astrocyte-derived, matrix-bound, and thus not soluble VEGF lowered  $\beta$ 1 integrin turnover in fibrillar adhesions. The results suggest that polarized VEGF release and

extracellular matrix (ECM) remodeling by VEGF-secreting cells is key to the control of the local concentration and signaling of VEGF, and they also highlight the importance of astrocytes in directing VEGF functions, identifying these mechanisms as promising targets for anti-angiogenic approaches.

## Additional Funding

- NSERC Postdoctoral Fellowship supporting Dr. Joshua Pemberton
- JSPS-NIH Fellowship supporting Dr. Takashi Baba

## Publications

1. Sohn M, Ivanova P, Brown HA, Toth DJ, Varnai P, Kim YJ, Balla T. Lenz-Majewski mutations in PTDSS1 affect phosphatidylinositol 4-phosphate metabolism at ER-PM and ER-Golgi junctions. *Proc Natl Acad Sci USA* 2016 113:4314-4319.
2. Klima M, Tóth DJ, Hexnerova R, Baumlova A, Chalupska D, Tykvart J, Rezabkova L, Sengupta N, Man P, Dubankova A, Humpolickova J, Nencka R, Veverka V, Balla T, Boura E. Structural insights and in vitro reconstitution of membrane targeting and activation of human PI4KB by the ACBD3 protein. *Sci Rep* 2016 6:23641.
3. Tóth JT, Gulyás G, Tóth DJ, Balla A, Hammond GR, Hunyady L, Balla T, Várnai P. BRET-monitoring of the dynamic changes of inositol lipid pools in living cells reveals a PKC-dependent PtdIns4P increase upon EGF and M3 receptor activation. *Biochim Biophys Acta* 2016 1861:177-187.
4. Kim YJ, Guzman-Hernandez ML, Wisniewski E, Echeverria N, Balla T. Phosphatidylinositol and phosphatidic acid transport between the ER and plasma membrane during PLC activation requires the Nir2 protein. *Biochem Soc Trans* 2016 44:197-201.
5. Egervari K, Potter G, Guzman-Hernandez ML, Salmon P, Soto-Ribeiro M, Kastberger B, Balla T, Wehrle-Haller B, Kiss JZ. Astrocytes spatially restrict VEGF signaling by polarized secretion and incorporation of VEGF into the actively assembling extracellular matrix. *Glia* 2016 64:440-456.

## Collaborators

- Evžen Boura, PhD, *Institute of Organic Chemistry and Biochemistry, Academy of Sciences of the Czech Republic, Prague, Czech Republic*
- Alex H. Brown, PhD, *Vanderbilt-Ingram Cancer Center, The Vanderbilt Institute of Chemical Biology, Vanderbilt University Medical School, Nashville, TN*
- Jozsef Z. Kiss, MD, *University of Geneva, Geneva, Switzerland*
- Péter Várnai, MD, PhD, *Semmelweis University, Faculty of Medicine, Budapest, Hungary*

## Contact

For more information, email [ballat@mail.nih.gov](mailto:ballat@mail.nih.gov) or visit <https://irp.nih.gov/pi/tamas-balla>.

## Structural and Chemical Biology of Membrane Proteins

Cell membranes lie at the heart of cellular compartmentalization. Integral membrane proteins, which are embedded in cell membranes, perform critically important functions, exemplified by the propagation of electrical signals along the cellular surface, exchange of material between two cellular compartments, and response of a cell to numerous signaling cues. We are interested in the structural basis of the function of several integral membrane protein families. Our approach calls for a combination of X-ray crystallography with functional analyses and a range of biochemical and biophysical techniques. In addition to solving high-resolution structures and using them to guide functional experiments, we also carry out experiments to investigate the role of membrane lipids in modulating the structure and function of membrane proteins. The experiments will provide novel insights into the structure and function of the membrane proteins and thus lead to new discoveries regarding the cellular processes in which they participate. Malfunctioning of the processes causes a wide range of human disorders such as multiple sclerosis, ataxia, and various forms of neuro-degenerative disease, to name but a few. Thus, in the process, we will also gain important insights into the biological underpinnings of these diseases.

### Structural studies on toxin block of K<sup>+</sup> channels

Potassium-selective channels (K<sup>+</sup> channels) are a large, diverse group of integral membrane proteins, crucial for proper cellular functioning. Toxins from animal venoms are able to specifically inhibit ion conduction of specific K<sup>+</sup> channel subtypes by binding to different parts of the channel; the toxins have thus emerged as indispensable tools in neuroscience. However, there is a dearth of available co-crystal structures of K<sup>+</sup> channel–toxin complexes, and thus the structural bases for the recognition of specific K<sup>+</sup> channels by specific toxins remain obscure. Currently, we are pursuing the structures of K<sup>+</sup> channels with toxins, specifically dendrotoxin, a component of snake venom. Given that different parts of K<sup>+</sup> channels are targeted by distinct toxins, the structure of each class of toxin–channel complex will lead to insights into unique aspects of this very important class of ion channels and their role in cellular physiology.



**Anirban Banerjee, PhD, Head,**  
*Unit on Structural and Chemical  
Biology of Membrane Proteins*

Eric Christenson, PhD,  
*Postdoctoral Fellow*

Raffaello Verardi, PhD,  
*Postdoctoral Fellow*

Jin-Sik Kim, PhD, *Visiting Fellow*

Pramod Kumar, PhD, *Visiting  
Fellow*

Chul-jin Lee, PhD, *Visiting Fellow*

Mitra Rana, PhD, *Visiting Fellow*

Austin Gallegos, BS,  
*Postbaccalaureate Fellow*

## Molecular mechanism of iron transport

We are focusing on mitochondrial inner-membrane transporters that bring iron into mitochondria. Subsequently, the iron is used in the biosynthesis of heme, a central component of hemoglobin, myoglobin, and cytochromes, and in the biosynthesis of iron-sulfur clusters, important cofactors required for proteins involved in a wide range of cellular activities, namely, electron transport in respiratory chain complexes, regulatory sensing, photosynthesis, and DNA repair. We are currently using heterologous expression to obtain enough purified material for biochemical and biophysical characterization.

## Structural and chemical biology approach to the design of novel antibiotics

Antibiotic-resistant pathogenic bacteria pose a major threat to our healthcare systems. In the face of this challenge, there is a pressing need to identify new targets for combating antibiotic-resistant bacteria and to identify and develop therapeutic leads that can result in clinically useful drugs. Clinically approved antibiotics that are currently in use mostly target bacterial cytosolic enzymes and the ribosome. Integral membrane proteins are, however, a largely uncharted territory for antibiotic development owing to difficulties in handling and purification, and importantly, to the lack of structural information. In collaboration with Clifton Barry's lab, we propose to combine fragment-based drug discovery (FBDD) with high-throughput screening (HTS), together with high-resolution structural analyses, to target integral membrane proteins involved in bacterial cell-envelope biosynthesis and to develop leads for novel antibacterial therapies. In the process, we hope to make fundamental discoveries regarding the mechanistic underpinnings of bacterial cell-envelope biosynthesis.

## Collaborators

- Clifton E. Barry III, PhD, *Laboratory of Clinical Infectious Diseases, NIAID, Bethesda, MD*
- Rodolfo Ghirlando, PhD, *Laboratory of Molecular Biology, NIDDK, Bethesda, MD*
- James Inglese, PhD, *Assay Development & Screening Technology Laboratory, NCATS, Bethesda, MD*

## Contact

For more information, email [anirban.banerjee@nih.gov](mailto:anirban.banerjee@nih.gov) or visit <http://banerjee.nichd.nih.gov>.

## Regulation of Childhood Growth

We investigate the cellular and molecular mechanisms governing childhood growth and development. We focus particularly on growth at the growth plate, which drives bone elongation and therefore determines height. One goal of this work is to gain insight into the many human genetic disorders that cause childhood growth failure or overgrowth. A second goal is to develop new treatments for children with severe growth disorders.

### Identifying genes responsible for childhood growth disorders

Children grow taller because their bones grow longer. Bone elongation occurs at the growth plate, a thin layer of cartilage found near the ends of juvenile bones. Within the growth plates, chondrocyte proliferation, hypertrophy, and cartilage matrix production result in chondrogenesis, the production of new cartilage. The newly formed cartilage is subsequently remodeled into bone. The net result is that new bone is progressively created, resulting in bone elongation. Consequently, mutations in genes that regulate growth-plate chondrogenesis cause abnormal bone growth in children (Reference 1). Depending on the severity and nature of the genetic abnormality, the clinical phenotype can range from chondrodysplasias with short, malformed bones, to severe, often disproportionate, short stature, to mild proportionate short stature (Reference 1). If the genetic defect affects tissues other than the growth-plate cartilage, the child may present with a more complex syndrome that includes other clinical abnormalities (Reference 1). For many children who are brought to medical attention for linear growth disorders, clinical evaluation and laboratory evaluation fail to identify the underlying etiology. Genome-wide association studies, which we have helped analyze (Reference 2; Wood AR *et al.*, *Nat Genet* 2014;46:1173-1186), and molecular-biological studies of growth-plate biology suggest that there are hundreds of genes that control linear growth. Therefore, it is likely that there are many genetic causes of linear growth disorders still to be discovered.

To discover new genetic causes of childhood growth disorders, we are using powerful genetic approaches, including single-nucleotide polymorphism (SNP) arrays to detect large deletions, duplications,

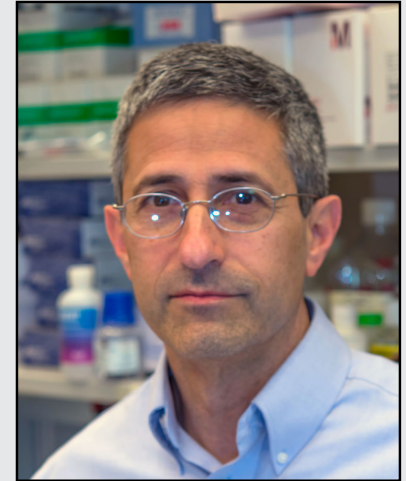

**Jeffrey Baron, MD**, *Head, Section on Growth and Development*

Kevin Barnes, PhD, *Senior Research Assistant*

Julian Lui, PhD, *Research Fellow*

Youn Hee Jee, MD, *Clinical Scholar*

Michal Ad, BS, *Postbaccalaureate Fellow*

Max Colbert, BA, *Postbaccalaureate Fellow*

Melissa Jennings, BS, *Postbaccalaureate Fellow*

Shanna Yue, BA, *Postbaccalaureate Fellow*

mosaicism, and uniparental disomy, combined with exome sequencing to detect single-nucleotide variants and small insertions/deletions in coding regions and splice sites. The analysis led to our identification of heterozygous mutations in *ACAN*, the gene encoding aggrecan, which cause autosomal dominant short stature with advanced bone age and premature osteoarthritis (Nilsson O *et al.*, *J Clin Endocrinol Metab* 2014;99:E1510-8.). We are participating in a multi-center collaboration to identify new families with this disorder in order to better characterize the clinical manifestations. We also identified compound heterozygous mutations in the *BRF1* gene (which encodes one of the three subunits of the RNA polymerase III transcription factor complex) in a family with autosomal recessive growth failure, markedly delayed bone age, and central nervous system anomalies, confirming a previous report that *BRF1* mutations cause cerebellar-facial-dental syndrome and further elucidating the phenotype. We also studied a subject with markedly accelerated skeletal and dental development, retinal scarring, and autism-spectrum disease and found elevated retinoic acid levels and a microdeletion on chromosome 18 10q23.2-23.33 that included the genes *CYP26A1* and *CYP26C1*, which both encode major retinoic acid-metabolizing enzymes (Reference 3). Given that retinoic acid accelerates skeletal development and is involved in development of the eye and central nervous system, it is likely that these gene deletions contribute to the patient's disorder.

## Exploring the links between childhood growth and oncogenesis

Many of the mechanisms that regulate mammalian body growth can, when disrupted, contribute to the development of malignancies. We studied the role of two heparin-binding growth factors, pleiotrophin and midkine, in the regulation of both normal body growth and in unregulated growth of malignancies.

To delineate the role of midkine and pleiotrophin in human development, we developed high-sensitivity assays to measure their concentrations in amniotic fluid at various gestational ages in both healthy and complicated pregnancies (Reference 4). We found that both growth factors could be readily measured in amniotic fluid and that the concentrations were higher than most cytokines previously reported in amniotic fluid. The concentration of midkine, but not that of pleiotrophin, declined with gestational age. We found both midkine and pleiotrophin concentrations to be lower in pregnancies that were complicated by chorioamnionitis at term, raising the possibility that the growth factors could be useful as markers for infection.

Previously, we measured midkine concentrations in fine-needle aspirate (FNA) samples from benign and malignant thyroid nodules to explore the possibility that midkine measurement might aid in the evaluation of thyroid nodules. We found that, in FNA samples, the midkine/thyroglobulin ratio in papillary thyroid cancer was greater than in benign thyroid nodules (Jee YH *et al.*, *Clin Endocrinol (Oxf)* 2015;83:977-984). More recently, we performed an analogous study of pleiotrophin and found that the pleiotrophin to thyroglobulin ratio was also higher in papillary thyroid cancer samples than in benign thyroid nodules (Reference 5). Thus, measurement of midkine and pleiotrophin concentrations in fine-needle aspirate samples may provide useful diagnostic and/or prognostic information in the evaluation of thyroid nodules.

## Developing targeted treatment approaches for growth-plate disorders

Currently, treatment approaches for linear growth disorders are limited. The principal treatment approach is administration of recombinant growth hormone, but it has limited efficacy for severe disease, including many skeletal dysplasias, and has significant known and potential adverse effects. Therefore, better treatments for severe growth disorders are needed. Studies by our lab and many other labs have identified



several paracrine factors that stimulate growth plate chondrogenesis and might therefore be used therapeutically. However, the therapeutic use of such molecules is challenging because they are produced locally and act locally in the growth plate, and thus do not lend themselves to systemic approaches. We hypothesized that these locally acting molecules could be targeted to the growth plate by linking them to cartilage-binding antibody fragments. When administered systemically, the hybrid molecules would be preferentially taken up by growth-plate cartilage, and thus might augment the therapeutic effect on the target organ while diminishing adverse effects from actions on other tissues. Similarly, growth-stimulating endocrine signals, such as growth hormone and insulin-like growth factor-I, might be targeted to the growth plate to increase the therapeutic effects on the growth plate and reduce adverse effects on other tissues. To develop a cartilage-targeting therapy, we used yeast display to identify antibody fragments that bound with high affinity to matrilin-3, an extracellular matrix protein expressed with high tissue specificity in cartilage (Reference 6). *In vivo*, the antibody fragments homed specifically to cartilage tissue in mice. Linking the antibody fragments to endocrine and paracrine factors that stimulate growth-plate chondrogenesis may open up new pharmacological approaches to treat childhood skeletal growth disorders.

Currently, we are constructing fusion proteins that combine matrilin-3-binding antibody fragments and paracrine factors that stimulate growth plate chondrogenesis. We are testing these fusion proteins *in vitro* and *in vivo* to determine their ability to bind to growth-plate cartilage, to interact with the relevant cell-surface receptors, and to increase growth-plate chondrogenesis without engendering significant off-target effects.

## Additional Funding

- Thrasher Research Fund Early Career Award to Youn Hee Jee (2014, ongoing): "The Role of Heparin Binding Growth Factors in Fetal and Childhood Growth"
- Clinical Center Genomic Opportunity Program (2104, ongoing): "Genetic Causes of Childhood Growth Failure"
- Merck-Serono Grant for Growth Innovation to Julian Lui (2014, ongoing): "Cartilage-Targeted Therapeutics for Growth Disorders"
- Endocrine Scholars Award in Growth Hormone Research to Julian Lui (2015, ongoing): "Cartilage-Targeted IGF-I for Treatment of Growth Disorders"
- Pediatric Endocrine Society Clinical Scholar Award to Youn Hee Jee (2016, ongoing): "The role of PSD-93 in the initiation of puberty and in the etiology of pubertal delay"

## Publications

1. Baron J, Säwendahl L, Phillip M, De Luca F, Dauber A, Wit JM, Nilsson O. Short and tall stature: a new paradigm emerges. *Nat Rev Endocrinol* 2015 11:735-746.
2. Pers TH, Karjalainen JM, Chan Y, Westra HJ, Wood AR, Yang J, Lui JC, Vedantam S, Gustafsson S, Esko T, Frayling T, Speliotes EK, Genetic Investigation of ANthropometric Traits (GIANT) Consortium, Boehnke M, Raychaudhuri S, Fehrmann RS, Hirschhorn JN, Franke L. Biological interpretation of genome-wide association studies using predicted gene functions. *Nat Commun* 2015 6:5890.
3. Nilsson O, Isoherranen N, Guo MH, Lui JC, Jee YH, Guttmann-Bauman I, Acerini C, Lee W, Allikmets R, Yanovski JA, Dauber A, Baron J. Accelerated skeletal maturation in disorders of retinoic acid metabolism: a

- case report and focused review of the literature. *Horm Metab Res* 2016 48(11):737-744.
4. Jee YH, Lebenthal Y, Chaemsaithong P, Yan G, Sacks DB, Wellstein A, Romero R, Baron J. Midkine and pleiotrophin concentrations in amniotic fluid in healthy and complicated pregnancies. *PLoS One* 2016 11:e0153325.
  5. Jee YH, Sadowski SM, Xi L, Raffeld M, Celi FS, Sacks DB, Remaley AT, Wellstein A, Kebebew E, Baron J. Increased pleiotrophin concentrations in papillary thyroid cancer. *PLoS One* 2016 11:e0149383.
  6. Cheung CS, Zhu Z, Lui JC, Dimitrov D, Baron J. Human monoclonal antibody fragments targeting matrilin-3 in growth plate cartilage. *Pharm Res* 2015 32:2439-2449.

## Collaborators

- Francesco Celi, MD, *Virginia Commonwealth University, Richmond, VA*
- Andrew Dauber, MD, *Boston Children's Hospital, Boston, MA*
- Angela Delaney, MD, *Unit on Genetics of Puberty and Reproduction, NICHD, Bethesda, MD*
- Dimiter Dimitrov, PhD, *Laboratory of Experimental Immunology, Center for Cancer Research, NCI, Frederick, MD*
- Joel Hirschhorn, MD, PhD, *Harvard Medical School, Boston, MA*
- Alexander A. Jorge, MD, *Universidade de São Paulo, São Paulo, Brazil*
- Electron Kebebew, MD, *Endocrine Oncology Branch, Center for Cancer Research, NCI, Bethesda, MD*
- Thomas Markello, MD, PhD, *Undiagnosed Diseases Program, NHGRI, Bethesda, MD*
- Ola Nilsson, MD, PhD, *Karolinska Institute, Stockholm, Sweden*
- Alan Remaley, MD, PhD, *Cardiovascular and Pulmonary Branch, NHLBI, Bethesda, MD*
- Katherine W. Roche, PhD, *Receptor Biology Section, NINDS, Bethesda, MD*
- Roberto Romero, MD, DMedSci, *Perinatology Research Branch, NICHD, Detroit, MI*
- David B. Sacks, MBChB, FRCPath, *Department of Laboratory Medicine, Clinical Center, NIH, Bethesda, MD*
- Anton Wellstein, PhD, *Georgetown University Medical Center, Washington, DC*
- Jan-Maarten Wit, MD, *Universiteit Leiden, Leiden, The Netherlands*
- Jack Yanovski, MD, PhD, *Section on Growth and Obesity, NICHD, Bethesda, MD*

## Contact

For more information, email [baronj@cc1.nichd.nih.gov](mailto:baronj@cc1.nichd.nih.gov) or visit <http://ugd.nichd.nih.gov>.

## Quantitative Imaging and Tissue Sciences

In our tissue sciences research, we strive to understand fundamental relationships between function and structure in living tissues, using 'engineered' tissue constructs and tissue analogs. Specifically, we are interested in how microstructure, hierarchical organization, composition, and material properties of tissues affect their biological function or dysfunction. We investigate biological and physical model systems at various relevant length and time scales, performing physical measurements in tandem with developing physical/mathematical models to explain salient features of these systems. Experimentally, we use water to probe both equilibrium and dynamic interactions among tissue constituents from nanometers to centimeters and from microseconds to lifetimes. To determine the equilibrium osmo-mechanical properties of well defined model systems, we vary water content or ionic composition systematically. To probe tissue structure and dynamics, we employ atomic force microscopy (AFM), small-angle X-ray scattering (SAXS), small-angle neutron scattering (SANS), static light scattering (SLS), dynamic light scattering (DLS), and one and two-dimensional nuclear magnetic resonance (NMR) relaxometry and diffusometry. A goal of our basic tissue sciences research is to translate our bench-based quantitative methodologies, and the understanding we glean from them, to the bedside.

Our basic and applied research in quantitative imaging dovetails with our tissue-sciences activities, which are intended to generate measurements and maps of intrinsic physical quantities, including diffusivities, relaxivities, or exchange rates, rather than relying on qualitative stains and images conventionally used in radiology. Our quantitative imaging group uses knowledge of physics, engineering, applied mathematics, imaging and computer sciences, and insights gleaned from our tissue-sciences research to discover and develop novel imaging biomarkers that sensitively and specifically detect changes in tissue composition, microstructure, or microdynamics. The ultimate translational goal of developing such biomarkers is to assess normal and abnormal development, diagnose childhood diseases, and characterize degeneration and trauma. Primarily, we use MRI as our imaging platform of choice because it is well suited for many NICHD-mission critical applications; it is non-invasive, non-ionizing, requires in most cases no exogenous contrast agents



**Peter J. Basser, PhD, Head,**  
*Section on Quantitative Imaging  
and Tissue Sciences*

Ferenc Horkay, PhD, *Staff Scientist*

Carlo Pierpaoli, MD, PhD, *Staff  
Scientist*

Alexandru Avram, PhD, *Intramural  
Research Training Award Fellow*

Neda Sadeghi, PhD, *Intramural  
Research Training Award Fellow*

Ruiliang Bai, PhD, *Visiting Fellow*

Dan Benjamini, PhD, *Visiting  
Fellow*

Jian Cheng, PhD, *Visiting Fellow  
(NIBIB)*

Amber Simmons, BS,  
*Postbaccalaureate Intramural  
Research Training Award Fellow*

Alan Barnett, PhD, *Contractor  
funded by the Henry Jackson  
Foundation's Center for  
Neuroscience and Regenerative  
Medicine (HJF-CNRM)*

Elizabeth Hutchinson, PhD,  
*Contractor funded by the HJF-  
CNRM*

Okan Irfanoglu, PhD, *Contractor  
funded by the HJF-CNRM*

*(continued)*

or dyes, and is deemed safe for use with fetuses and children in both a clinical and research setting.

One of our technical objectives has been to make clinical MRI scanners, rather than qualitative radiological devices, scientific instruments capable of producing reproducible, highly accurate, and precise imaging data to be able to measure and map useful imaging quantities for various applications, including single scans, longitudinal and multi-site studies, personalized medicine, and for populating imaging databases with high-quality normative data.

## In vivo MRI histology

We aim to develop novel next-generation *in vivo* MRI methods to better understand brain structure and organization in normal and abnormal development, disease, degeneration, and trauma. The most mature technology that we invented and developed is Diffusion Tensor MRI (DTI), by which we measure a diffusion tensor of water,  $D$ , voxel-by-voxel within an imaging volume. Information derived from this quantity includes white matter fiber-tract orientation, the mean-squared distance that water molecules diffuse in each direction, the orientationally averaged mean diffusivity, and

Sarah King, PhD, Contractor  
funded by the HJF-CNRM  
Michal Komlosh, PhD, Contractor  
funded by the HJF-CNRM  
Amritha Nayak, MS, Contractor  
funded by the HJF-CNRM  
Laura Reyes, PhD, Contractor  
funded by the HJF-CNRM  
Cibu Thomas, PhD, Contractor  
funded by the HJF-CNRM  
Jeffrey Jenkins, MS, Contractor  
funded by Congressionally  
Directed Medical Research  
Programs (CDMRP) and Catholic  
University of America

**FIGURE 1.** Direction-encoded color (DEC) maps of the normal developing brain

DTI templates. Examples of DEC maps computed from age-specific average brain DTI templates obtained using diffeomorphic tensor-based registration of the DTI data of the individual subjects (Zhang H *et al.* *IEEE Trans Med Imaging* 2007;26:1585). Two types of DTI templates are available for download from the PedsDTI database: morphologically faithful templates, which represent the average morphology of the subjects included in each age group (top row), and morphologically normalized templates in which the average brain is further warped to the morphology of the 18–20 year old group (bottom row).

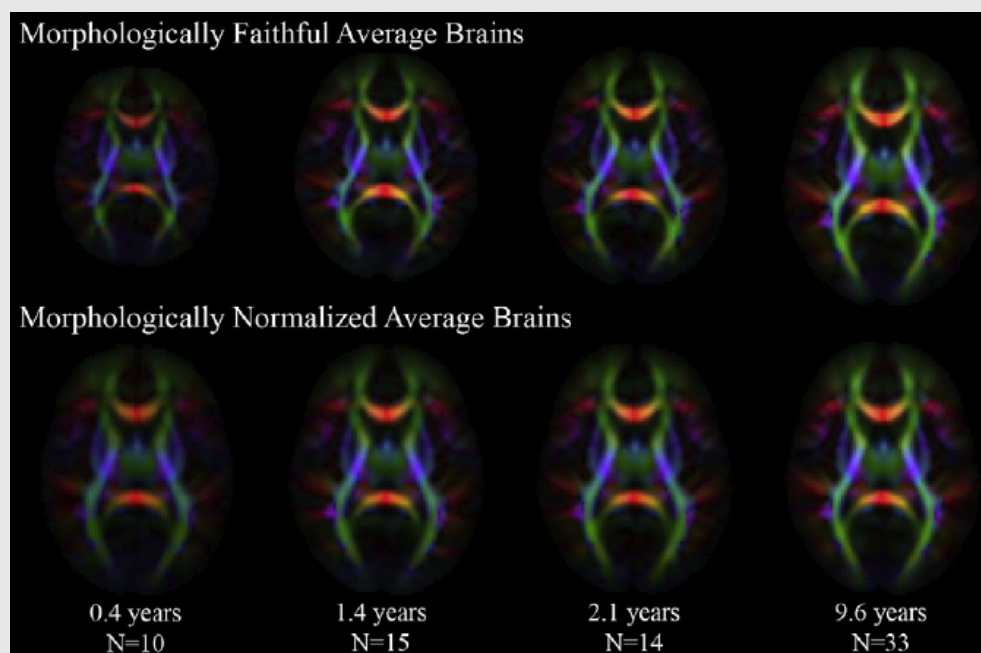

other intrinsic scalar (invariant) quantities. The imaging parameters behave like non-invasive quantitative histological ‘stains’ obtained by probing endogenous tissue water without requiring exogenous contrast agents or dyes. The bulk or orientationally averaged apparent diffusion coefficient (mean ADC) is the most successful and widely used DTI parameter to identify ischemic regions in the brain during acute stroke, as well as for many other indications. Our measures of diffusion anisotropy (e.g., fractional anisotropy or FA) are universally used to follow changes in normally and abnormally developing white matter, including dysmyelination and demyelination. Our group also pioneered the use of fiber direction–encoded color (DEC) maps to display the orientation of the main association, projection, and commissural white matter pathways in the brain. To assess anatomical connectivity among various cortical and deep brain gray matter areas, we also proposed and developed DTI “Streamline” Tractography.

More recently, we invented and developed a family of advanced *in vivo* diffusion MR methods to measure fine-scale microstructural features of axons and fascicles, which otherwise could only be measured using laborious *ex vivo* histological methods. We have been developing efficient means for performing “k and q-space MRI” in the living brain, the most recent being “Mean Apparent Propagator” (MAP) MRI. This approach can detect subtle microstructural and architectural features in both gray and white matter

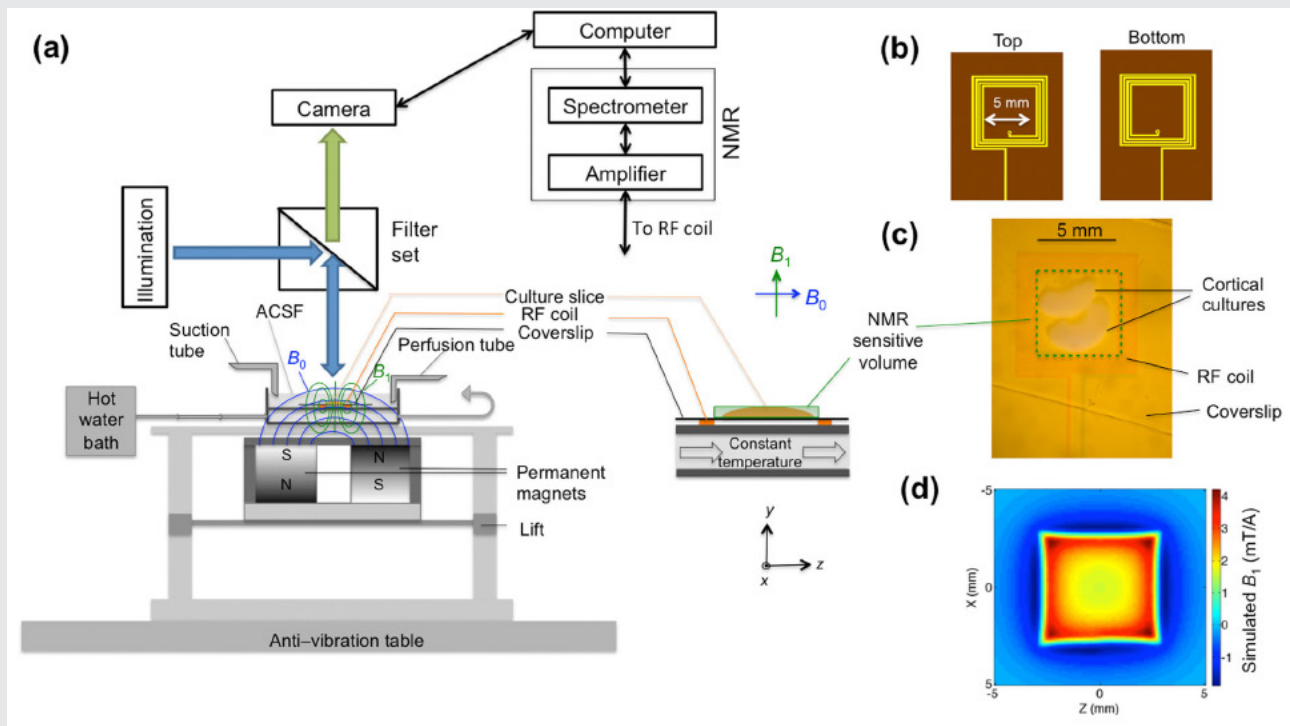
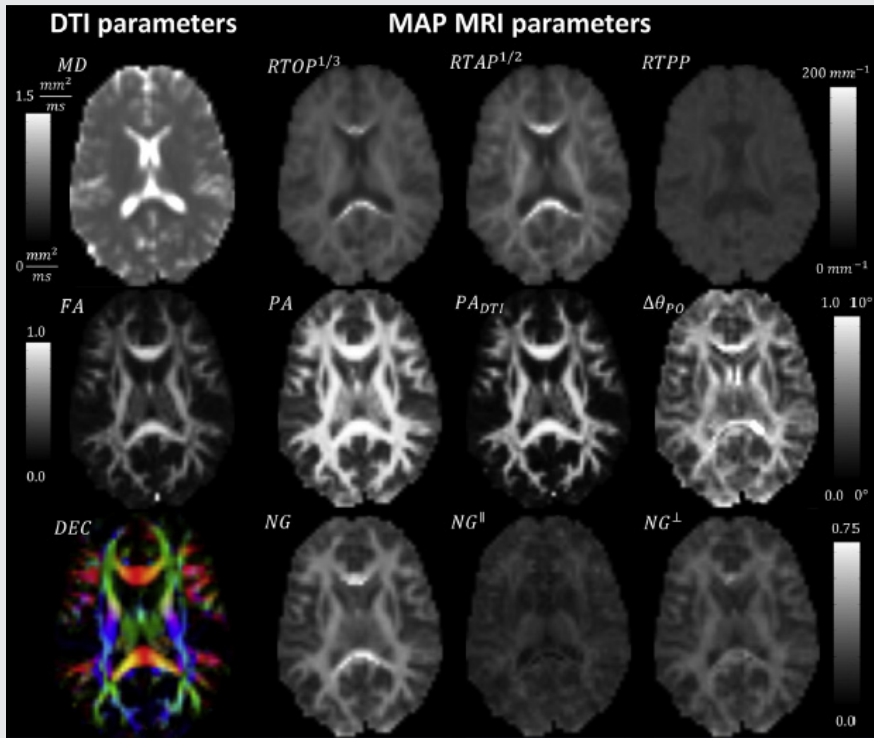

FIGURE 2. Novel instrument for simultaneous functional MR and calcium imaging studies

Schematic diagram of a novel instrument for simultaneous functional MR and calcium imaging studies of organotypic cultured brain tissue. (a) Schematic diagram of the simultaneous MR and fluorescence imaging test bed (left) and an enlargement of the components near the organotypic cultured tissue (right), which is immersed in artificial cerebral spinal fluid (ACSF). (b) Top and bottom layers of the two-layer multi-turn radio-frequency (RF) surface coil. (c) Real image of the coil with the cortical culture mounted under approximately 0.63x magnification. (d) Simulated two-dimensional  $B_1$  field distribution at  $y = 0.2$  mm in the  $x$ - $z$  plane.



**FIGURE 3.** MAP-MRI provides a new family of imaging biomarkers for brain imaging.

Neuroanatomical variation of Mean Apparent Propagator (MAP) MRI and DTI microstructural parameters in a representative subject. DTI-derived parameters: MD, FA, and directionally encoded color (DEC) maps (left). MAP MRI-derived zero-displacement probabilities, propagator anisotropy, and non-Gaussianity indices (right).

at micron-scale resolution. It also subsumes DTI, as well as providing a bevy of new *in vivo* quantitative 'stains' to measure and map. We also developed a family of diffusion MRI methods to 'drill' down into the voxel and measure features such as average axon diameter (AAD) and axon diameter distribution (ADD) within large white-matter fascicles, dubbing them CHARMED and *AxCaliber* MRI, respectively. After careful validation studies, we reported the first *in vivo* measurement of ADDs within the rodent corpus callosum. The ADD is important neuro-physiologically and developmentally given that axon diameter helps determine its conduction velocity and therefore affects the rate of information transfer along white matter pathways and consequently delays or latencies between and among different brain areas. We then developed a companion mathematical theory to explain the observed ADDs in different fascicles, suggesting that they represent a trade-off between information flow and metabolic demands. We also developed novel multiple pulsed-field gradient (mPFG) methods and demonstrated their feasibility for use *in vivo* on conventional clinical MRI scanners as a further means to extract quantitative features to measure and map in the central nervous system (CNS). The methods can also provide an independent measurement of the AAD and other features of cell size and shape.

Although brain gray matter appears featureless in DTI maps, its microstructure and architecture are rich and varied, not only along the brain's cortical surface, but also within and among its various cortical layers and within deep gray matter regions. To target the tissue, we have been developing several noninvasive, *in vivo* methods to measure unique features of cortical gray matter microstructure and architecture that are currently invisible in conventional MRI. One goal is to 'parcellate' or segment the cerebral cortex *in vivo* into its approximately 500 distinct cyto-architectonic or Brodmann-like areas. To this end, we are developing

advanced MRI sequences to probe correlations among microscopic displacements of water molecules in the neuropil as well as sophisticated mathematical models to infer distinguishing microstructural and morphological features of gray matter. We recently pioneered and developed several promising MRI relaxometry and diffusometry methods, which we plan to use to study water mobility and exchange in gray matter.

In general, we are continuing to develop translationally oriented methods to follow normal and abnormal development, aid in the diagnosis of various diseases and disorders affecting the cerebral cortex, noninvasively and *in vivo*, and provide information to help neurosurgeons plan operations and interventions.

## Quantitative pediatric MRI

MRI is considered safer than X-ray-based methods, such as computed tomography (CT), for scanning infants and children. However, clinical MRI data still lacks the quantitative character of CT data. Clinical MRI relies upon the acquisition of 'weighted images,' whose contrast is affected by many factors, some intrinsic to the tissue and some dependent on the details of the experiment and experimental design. The diagnostic utility of conventional MRI for many neurological disorders is unquestionable. However, the scope of conventional MRI applications is limited to revealing either gross morphological features or focal abnormalities, which result in regional differences in signal intensities within a given tissue. To detect pathology, conventional MRI relies on differences in contrast between areas that are presumed 'affected' and those presumed 'normal,' rendering it intrinsically insensitive to subtle global changes that may affect the entire tissue or organ. Clinical MRI also lacks biological specificity. Although quantification *per se* does not ensure improved specificity, it is nonetheless necessary for developing robust and reliable imaging 'biomarkers.' In particular, MRI assessment of normal brain development and developmental disorders has benefited greatly from the introduction of 'quantitative' clinical MRI techniques, in which one obtains maps of meaningful physical quantities or chemical variables that can be measured in physical units and compared among different tissue regions, in both longitudinal and cross-sectional studies. Quantitative MRI methods, such as DTI, also increase sensitivity, providing a basis for monitoring subtle changes that occur, e.g., during the progression or remission of disease, by comparing measurements in a single subject with normative values acquired in a healthy population. Quantitative MRI methods should also aid in precision imaging studies, whereby MRI phenotypic data can be meaningfully combined with a subject's genotype.

Our group has been carrying out several clinical studies that utilize novel quantitative MRI acquisition and analysis methods, whose aim is to improve accuracy and reproducibility in diagnosis and to detect and follow normal and abnormal development. These studies include the following:

- 1) The NIH Study of Normal Brain Development, jointly sponsored by a consortium of four NIH Institutes (NICHD, NIMH, NINDS, and NIDA), was a multi-center effort to advance our understanding of normal brain development in typical healthy children and adolescents. The Brain Development Cooperative Group ([http://www.brain-child.org/brain\\_group.html](http://www.brain-child.org/brain_group.html)), created by this mechanism, is still active, publishing numerous papers each year, primarily by mining these rich data. Tandem structural MRIs and standardized neuropsychological tests performed on this population are also available to researchers outside the consortium. Our role in this interdisciplinary project was as the DTI Data-Processing Center (DPC). While we have now processed all admissible DTI data and uploaded them to a database accessible to all interested investigators, we continue to mine and analyze the data, having recently developed age-specific DTI atlases of normal brain

development. We also publicly released various versions of software that we developed for this project (and related documentation), which can be downloaded from <http://www.tortoisediti.org>. We continue to support and update the software. We are continuing to use this advanced DTI-processing pipeline to produce high-quality normative data from the project, which we make publicly available through the National Database for Autism Research (NDAR; <http://ndar.nih.gov>).

2) In collaboration with Susan Swedo, we study autistic subjects using DTI and quantitative MRI relaxometry methods. While several MRI studies reported abnormal features in the autistic brain, no clear MRI 'biomarker' of autism exists. The aim of the study is to use robust quantitative metrics to identify potential anatomical abnormalities in the autistic brain and to find candidate imaging biomarkers for this disorder (an earlier study was described in Walker *et al. Biol Psychiatry* 2012;72:1043).

3) In collaboration with Katherine Warren, we acquire quantitative MRI data in children with pontine gliomas to identify MRI prognostic factors. With John Park, we had been scanning subjects with supratentorial gliomas to distinguish recurrence from radiation necrosis.

4) In collaboration with Filippo Arrigoni, we use multi-modal MR imaging (DTI, fMRI, and quantitative relaxometry) to evaluate cerebral reorganization caused by various rehabilitation protocols in children with cerebral palsy and traumatic brain injury (TBI). We collected diffusion MRI data on subjects affected by the pure form of hereditary spastic paraparesis, as well as those with additional cognitive impairment. There are remarkable neuroanatomic differences between the two groups.

5) We are working under the auspices of the Center for Neuroscience and Regenerative Medicine (CNRM), DoD, to investigate potential plasticity changes after rehabilitation in military personnel affected by TBI and post-traumatic stress disorder (PTSD). We are also exploring the clinical utility of MAP-MRI to provide quantitative imaging biomarkers that are sensitive and specific enough to detect mild TBI (mTBI).

6) In collaboration with Sharon Juliano, we received grant support from the Congressionally Directed Medical Research Program (CDMRP) to investigate TBI in the ferret, using advanced MRI methods, particularly MAP-MRI, developed within our laboratory, combined with histopathological techniques provided by Juliano's laboratory. We are currently acquiring MRI data.

7) In collaboration with the Veteran's Administration, DoD, and the Chronic Effects of Neurotrauma Consortium (CENC), we are enabling the acquisition of multi-site DTI data from various clinical centers in the VA network.

Our involvement in TBI research, particularly in detecting mTBI, is expanding, because it is of high relevance to the NICHD mission and because it is an acute problem in the pediatric population, as well as young military men and women. DTI provides essential information for the diagnosis of TBI and has the potential to be developed into an important tool for the assessment of potential structural damage in PTSD. For clinical applications, however, reliable imaging protocols are needed. Part of our work is to develop a robust DTI data-processing pipeline in order to improve the accuracy and reproducibility of DTI findings for CNRM investigators and for the larger clinical and scientific community involved in TBI research. To this end, we are adding new modules to our existing state-of-the-art DTI data-processing pipeline as well as tools



to permit calibration of DTI experiments, using our novel polymer-based diffusion MRI phantom that we developed and are disseminating to a number of clinical sites.

Looking ahead, to permit analysis of novel MRI data such as those described above, as well as to develop new clinical and biological applications of quantitative MRI, we need to create a mathematical, statistical, and image sciences-based infrastructure. To date, we have developed algorithms that generate a continuous, smooth approximation of the discrete, noisy, measured DTI field data so as to reduce noise and allow us to follow fiber tracts more reliably. We proposed a novel Gaussian distribution for tensor-valued random variables that we used in designing optimal DTI experiments and interpreting their results. In tandem, we developed non-parametric empirical (e.g., Bootstrap) methods to determine the statistical distribution of DTI-derived quantities in order to study, for example, the inherent variability and reliability of computed white-matter fiber-tract trajectories. Such parametric and non-parametric statistical methods enable us to apply powerful hypothesis tests to assess the statistical significance of findings in a wide range of important biological and clinical applications that are currently being tested using *ad hoc* statistical methods. We are also developing novel methods to register or warp different brain volumes and to generate group-average data or atlases from subject populations. Recently, our group has been developing methods for studying the reproducibility and reliability of different tractography methods, given that they are being used increasingly to assess anatomical connections between different brain regions *in vivo*. In the area of artifact remediation and correction, we pioneered methods to correct for subject motion and for artifacts caused by induced eddy-current and echo-planar imaging (EPI) distortion. However, much work remains to be done in order to address and remedy MRI artifacts to permit one to draw statistically significant inferences from clinical DTI data, obtained in longitudinal and multi-center studies but particularly in single subject studies.

## Biopolymer physics: water-ion-biopolymer interactions

Molecular self-organization is ubiquitous in biology. For example, self-assembly of aberrant proteins into nanofibers is associated with neurodegenerative conditions, such as Creutzfeldt-Jakob, Alzheimer's, and Pick's disease. Water-ion-biopolymer interactions govern the organization of biological macromolecules and help determine the functional properties of cell and tissue constituents. One objective of our research is to better understand self-assembly and fiber formation of biomolecules from a physical perspective by studying the interactions between and among water, ions, and biopolymers.

To determine the effect of ions on the structure and dynamic properties of tissue components, we developed a multi-scale experimental framework by combining macroscopic techniques (e.g., osmotic swelling pressure measurements, mechanical measurements) with higher-resolution scattering methods (e.g., SANS and SAXS). Swelling pressure measurements provide information on the overall thermodynamic response, while SANS and SAXS allow us to investigate biopolymers at the molecular and supramolecular levels and to quantify the effect of ion concentration, ion valance, pH, and temperature on the structure and macroscopic (thermodynamic) properties of the tissue.

Divalent cations, particularly calcium ions, are abundant in the biological milieu. In pilot studies, we determined the effect of calcium ions on the physical properties of hyaluronic acid (HA) and DNA gels. These systems mimic certain essential features of the extracellular matrix (ECM) and have a potential as scaffolds for tissue-regeneration applications. We also developed a biomimetic model of cartilage ECM consisting

of polyacrylic acid (PAA) microgel particles embedded in a polyvinyl alcohol (PVA) gel. In this system, PAA mimics the behavior of proteoglycan assemblies and PVA mimics the collagen matrix.

In collaboration with the University of Utah, we investigated the binding mechanism in glucose sensors made from smart zwitterionic hydrogels containing boronic acid moieties. This class of material is important for the development of implantable continuous glucose sensors for use in managing Type I and Type II diabetes. Our combined SANS and osmotic pressure measurements provided a thermodynamic explanation for the enhanced selectivity of the gels for glucose over fructose.

Intracellular formation of molecular assemblies could be used to selectively inhibit the growth of cells that over-express certain enzymes. We studied nano-structures formed from small gelator molecules via enzyme-assisted self-assembly inside live cells. The gelator molecule consists of a self-assembly motif and an enzyme (phosphatase) substrate (tyrosine phosphorous ester). After the enzymatic removal of the phosphorous group, intermolecular interactions facilitate the self-assembly of the gelator molecules, leading to the formation of nano-fibers. We developed an *in situ* tumor-specific formation of self-assemblies to enrich indocyanin green (ICG) for fluorescence/photo-acoustic dual-modality imaging-guided photo-thermal therapy (PTT). The ICG-doped nonofibers exhibit enhanced NIR absorbance and unique photo-acoustic and photo-thermal properties and can potentially be used to develop nanostructures for clinical translatable PTT theranostics, or guidance of surgical resection. (This project was performed in collaboration with the National Institute of Biomedical Imaging and Bioengineering NIBIB and sponsored by the National Research Council and the National Academy of Sciences.)

## Functional properties of extracellular matrix (ECM)

Our goal is to understand and quantify the interactions among the major macromolecular components of ECM that give rise to their key functional properties. ECM is present in every tissue and performs a key role in determining normal and abnormal organ function. Specifically, we are studying interactions among the primary ECM components: collagen, proteoglycans (PG), water, and ions, which govern macroscopic biomechanical and transport properties, using cartilage as a model system. The biomechanical behavior of cartilage and other ECMs reflects biochemical and microstructural changes occurring during development, disease, degeneration, and aging. Understanding the basis of key functional properties of cartilage requires an array of experimental techniques that probe a wide range of relevant length and time scales. Understanding the physical and chemical mechanisms affecting cartilage swelling (hydration) is essential for predicting its load-bearing and lubricating abilities, which are mainly governed by osmotic and electrostatic forces. The knowledge can inform tissue-engineering or regenerative-medicine strategies to grow, repair, and reintegrate replacement cartilage. To obtain a self-consistent physical picture of tissue structure/function relationships, we measure various physical/chemical properties of tissues and tissue analogs at different length- and time-scales using a variety of complementary static and dynamic experimental techniques, e.g., osmometry, SANS, SAXS, neutron spin-echo (NSE), SLS, DLS, AFM, and fluorescence correlation spectroscopy (FCS).

Controlled tissue hydration provides a direct means of determining the patency and load-bearing ability of cartilage. We designed and built a tissue micro-osmometer to perform high-precision swelling pressure measurements on small tissue samples (less than 1 microgram) as a function of the water activity (vapor pressure). We make osmotic pressure measurements to determine how the individual components

of cartilage ECM (e.g., aggrecan, HA, and collagen) contribute to the total load-bearing capacity of the tissue. We demonstrated that aggrecan-HA assemblies behave like microgels, contributing to improved dimensional stability and tissue-lubricating ability. We also found that aggrecan is highly insensitive to changes in the ionic environment, particularly to  $\text{Ca}^{2+}$  ions, which is critically important in aggrecan's role as a calcium ion reservoir mediating calcium metabolism in cartilage and bone.

The resistance of tissue to external loads is determined by its osmotic modulus. Therefore, maps of the osmotic modulus are particularly useful for characterizing the load-bearing properties of cartilage. We developed a method that utilizes the precise scanning capabilities of the AFM to generate compliance maps, from which relevant elastic properties can be extracted. We then combined AFM with tissue micro-osmometry to generate elastic and osmotic modulus maps of cartilage.

We have begun translating this critical tissue-sciences understanding of the structure/function relationships of components of ECM to develop and design novel non-invasive MR imaging methods with the aim of inferring ECM composition, patency, and functional properties *in vivo*. Our goal is to use MRI for early diagnosis of cartilage and other ECM diseases, as well as to provide a means for following normal and abnormal development of the ECM. This challenging project entails making 'invisible' components of ECM, (e.g., collagen and PGs) 'visible' and then using our understanding of biopolymer interactions to predict tissue patency. One major challenge is that water molecules bound to immobile species (e.g., collagen) cannot be visualized with conventional proton density MRI. However, magnetization transfer (MT) MRI makes it possible to detect the bound protons indirectly by transferring their magnetization to the free water. It also makes it possible to estimate the collagen content in tissue. In a pilot study, we applied the new MT MRI method to determine the concentration and distribution of the main macromolecular constituents in bovine femoral-head cartilage samples. The results obtained by the MT MRI method were qualitatively consistent with those obtained by histological techniques, such as high definition infrared (HDIR) spectroscopy. Our work has been aided by our receipt of a DIR Director's Award to investigate this proposed line of research, along with our NICHD collaborators Sergey Leikin and Edward Mertz.

## Additional Funding

- Award 305500-1.01-60855 from the Henry Jackson Foundation supports the Section's project in "Enhanced Software Tools for the Analysis of Diffusion MRI in TBI and PTSD," which is under the joint auspices of the NIH, DoD, CNRM, and USUHS.
- Award 306135-2.01-60855 from the Henry Jackson Foundation supports the Section's project "Clinical Double Pulsed-Field Gradient (dPFG) MRI for Mild TBI Assessment," which is under the joint auspices of the NIH, DoD, CNRM, and USUHS.

## Publications

1. Avram AV, Sarlls JE, Barnett AS, Özarslan E, Thomas C, Irfanoglu MO, Hutchinson E, Pierpaoli C, Basser PJ. Clinical feasibility of using mean apparent propagator (MAP) MRI to characterize brain tissue microstructure. *Neuroimage* 2016 127:422-434.
2. Walker L, Chang L-C, Nayak A, Irfanoglu MO, Botteron KN, McCracken J, McKinstry RC, Rivkin MJ, Wang D-J, Rumsey J, Pierpaoli C, the Brain Development Cooperative Group. The diffusion tensor imaging (DTI)

- component of the NIH MRI study of normal brain development (PedsDTI). *Neuroimage* 2016 124(Pt B):1125-1130.
3. Bai R, Klaus A, Bellay T, Stewart C, Pajevic S, Nevo U, Merkle H, Plenz D, Basser PJ. Simultaneous calcium fluorescence imaging and MR of ex vivo organotypic cortical cultures: a new test bed for functional MRI. *NMR Biomed* 2015 28(12):1726-1738.
  4. Sadeghi N, Nayak A, Walker L, Irfanoglu MO, Albert P, Pierpaoli C, Brain Development Cooperative Group. Analysis of the contribution of experimental bias, experimental noise, and inter-subject biological variability on the assessment of developmental trajectories in diffusion MRI studies of the brain. *Neuroimage* 2015 109:480-492.
  5. Horkay F. Interaction of cartilage biopolymers. *Macromol Symp* 2015 358:78-84.

## Collaborators

- Filippo Arrigoni, MD, *Fondazione IRCCS Eugenio Medea, Bosisio Parini, Italy*
- Madison Berl, PhD, *Children's National Medical Center, Washington, DC*
- Emiliios Dimitriadis, PhD, *Division of Bioengineering and Physical Science, NIBIB, Bethesda, MD*
- Uzi Eliav, PhD, *Tel Aviv University, Tel Aviv, Israel*
- Erik Geissler, PhD, *CNRS, Université Joseph Fourier de Grenoble, Grenoble, France*
- Iren Horkayne-Szakaly, MD, *Armed Forces Institute of Pathology, Washington, DC*
- Sharon Juliano, PhD, *Uniformed Services University of the Health Sciences, Bethesda, MD*
- Sergey Leikin, PhD, *Section on Physical Biochemistry, NICHD, Bethesda, MD*
- Stefano Marenco, PhD, *Clinical Brain Disorders Branch, NIMH, Bethesda, MD*
- Edward L Mertz, PhD, *Section on Physical Biochemistry, NICHD, Bethesda, MD*
- Pedro Miranda, PhD, *Universidade de Lisboa, Lisbon, Portugal*
- Gil Navon, PhD, *Tel Aviv University, Tel Aviv, Israel*
- Uri Nevo, PhD, *Tel Aviv University, Tel Aviv, Israel*
- Evren Özarslan, PhD, *Brigham and Women's Hospital, Boston, MA*
- Sinisa Pajevic, PhD, *Mathematical and Statistical Computing Laboratory, CIT, NIH, Bethesda, MD*
- John Park, MD, PhD, *Surgical Neurology Branch, NINDS, Bethesda, MD*
- Bradley Roth, PhD, *Oakland University, Rochester, MI*
- Susan Swedo, MD, *Pediatrics and Developmental Neuroscience Branch, NIMH, Bethesda, MD*
- Lindsay Walker, MSc, *Brown University, Providence, RI*
- Katherine Warren, MD, *Pediatric Oncology Branch, Center for Cancer Research, NCI, Bethesda, MD*
- Brain Development Cooperative Group, *Various*

## Contact

For more information, email [pjbasser@helix.nih.gov](mailto:pjbasser@helix.nih.gov) or visit <http://sqits.nichd.nih.gov>.

## Biophysics of Large Membrane Channels

We study mitochondrial and bacterial membrane proteins that form the “large” beta-barrel channels responsible for metabolite fluxes between cells and cellular compartments. In particular, we are interested in the physical mechanisms of their functioning and regulation under normal and pathological conditions. Among many wet-lab approaches, such as fluorescence correlation spectroscopy, bilayer overtone analysis, and confocal microscopy, our hallmark method is reconstitution of these proteins into planar lipid membranes in order to study them at the single-molecule level. Empirical findings obtained in these experiments are rationalized within the framework of a physical theory of channel-facilitated transport, an understanding that is necessary to design new strategies to effectively correct the deviant interactions associated with disease.

In contrast to the highly ion-selective channels studied in neurophysiology, which have narrow selectivity filters to match the size of a partially dehydrated ion, metabolite or “nutrient” channels are significantly wider. Indeed, they have to accommodate metabolite molecules that are typically much larger than simple mono- or divalent ions. Because of their size and primarily beta-barrel scaffolds, the mechanisms of the selectivity and gating of these channels are quite different from those of the highly ion-selective channels formed from alpha-helical subunits. To grasp the general principles of beta-barrel channel functioning and regulation, we work with a variety of proteins and channel-forming peptides. Among them are VDAC (voltage-dependent anion channel from the outer membrane of mitochondria), alpha-Hemolysin (toxin from *Staphylococcus aureus*), translocation pores of *Bacillus anthracis* (PA63), *Clostridium botulinum* (C2IIa) and *Clostridium perfringens* (Ib) binary toxins, Epsilon toxin (from *Clostridium perfringens*), OmpF (general bacterial porin from *Escherichia coli*), LamB (sugar-specific bacterial porin from *Escherichia coli*), OprF (porin from *Pseudomonas aeruginosa*), Syringomycin E (lipopeptide toxin from *Pseudomonas syringae*), and the bacterial peptide TisB, which is involved in persister cell biofilm formation. We also use Gramicidin A (linear pentadecapeptide from *Bacillus brevis*) as a molecular sensor of membrane-mechanical properties. To study the channel-forming proteins under controlled conditions, we first isolate them from their



**Sergey M. Bezrukov, PhD, DSci,**  
*Head, Section on Molecular  
Transport*

Philip A. Gurnev, PhD, *Staff  
Scientist*

Tatiana K. Rostovtseva, PhD, *Staff  
Scientist*

Amandine Rovini, PhD, *Visiting  
Fellow*

host organisms, purify them, and then reconstitute them into planar lipid bilayers, a model system with precisely defined physical properties. This allows us to explore channel interactions with the lipid membrane as modified by volatile anesthetics, by cytosolic proteins, such as tubulin and alpha-synuclein, and by newly synthesized drugs, such as blockers of the translocation pores of bacterial toxins. Our motivation is that learning the molecular mechanisms of channel functioning is vital for developing new approaches to treatment of various diseases for which regulation of transport through ion channels plays the key role.

## Partitioning of soft water-soluble polymers into beta-barrel channels in their functional states

The cell is a crowded place. As an example, volume concentration of macromolecules in the cytoplasm of *Escherichia coli* is as high as 30–40%, leading to significant deviations of macromolecular reaction rates and equilibria from those in diluted samples. The current consensus is that the functional outcomes of

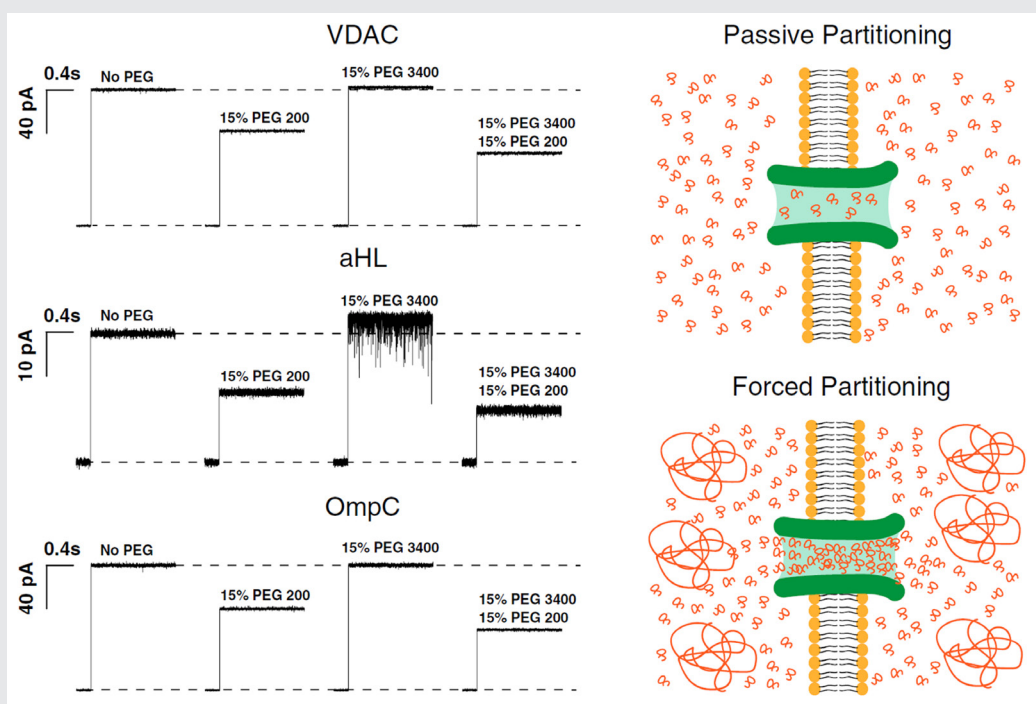
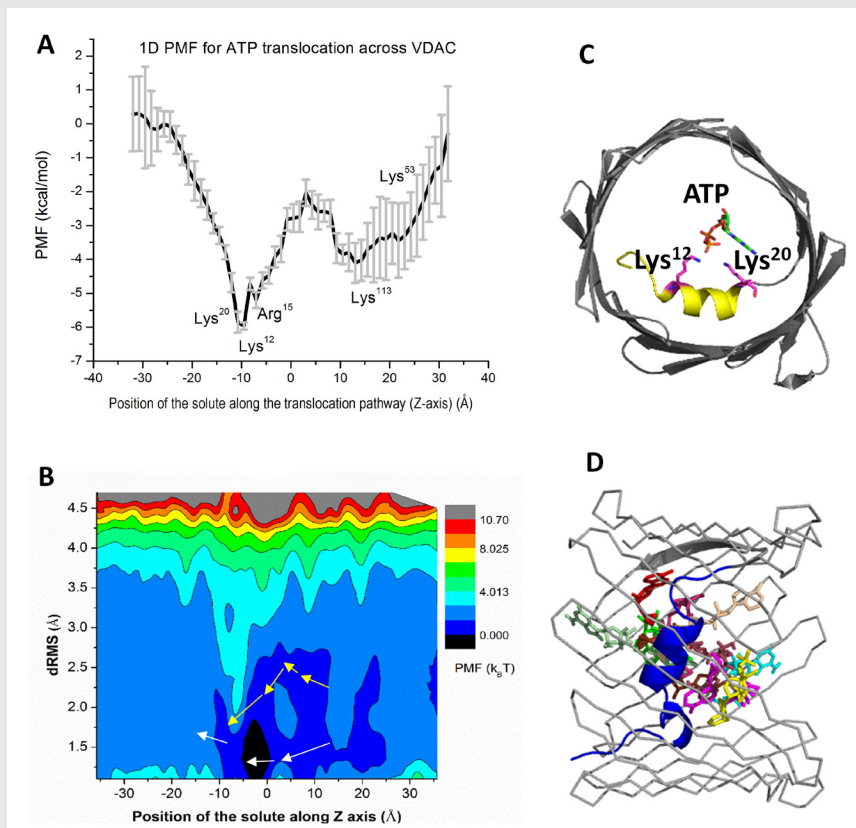

FIGURE 1. Polymers pushing polymers: the effect of differently sized PEGs and their mixtures on channel conductance (Reference 1)

Traces labeled “No PEG” show the current jump immediately after spontaneous channel formation. Addition of 15% (wt/wt) PEG200 causes a significant drop in single-channel conductance: 30% in case of VDAC; 45% in case of alpha-Hemolysin (aHL); and 35% in case of OmpC. Addition of 15% (wt/wt) PEG 3400, which does not penetrate the channel at this concentration, causes an apparent increase in single-channel conductance (VDAC, 2%; aHL, 10%; and OmpC, 2%). Addition of 15% (wt/wt) PEG200 along with 15% (wt/wt) of PEG3400 reduces the channel conductance by an extra 15% as a result of additional PEG200 partitioning into the pore, as it is “pushed” by PEG3400 molecules in the bathing solution. Current jumps after PEG addition correspond to the moments of transmembrane voltage application of 30 mV.



**FIGURE 2. ATP translocation facilitated by interactions with VDAC pore residues (Reference 3)**

One- (A) and two-dimensional (B) Potentials of Mean Force (PMF) for ATP transport across VDAC1 channel. In 2D PMF simulations, each replica (window) makes periodic exchange attempts with its four neighboring replicas. In each exchange cycle, exchange attempts are performed alternatively along the two dimensions to accelerate the travel through the extended ensemble. The permeation pathways mapped from simulations are shown in white arrows, while the pathway 5 from the Markov-State-Model (MSM) analysis is illustrated with yellow arrows. (C) The high-affinity site identified from 1D PMF computations. (D) The top 10 most likely ATP conformations along the permeation pathway are shown.

molecular crowding stem from two phenomena: hard-core repulsions, otherwise referred to as “entropic effects,” and soft chemical interactions. This year, we demonstrated that the entropic effects are generally more subtle than just the hard-core repulsions, because they necessarily include the phenomenon of forced macromolecule partitioning into protein cavities (Reference 1). With consequences for the selective sorting of large molecules in cells, studies of polymer partitioning into nanopores are also instructive for refining single-molecule sensing (Reference 2) as well as for polymer-assisted transport and packaging.

To address these questions, we analyzed forced size-dependent partitioning of binary mixtures of differently sized polyethylene glycols (PEGs) in nanosize pores. We probed three structurally different channels: VDAC from the outer mitochondrial membrane, bacterial porin OmpC (outer membrane protein C), and bacterial channel-forming toxin alpha-Hemolysin (Figure 1). Our interpretation was based on the idea that relatively less-penetrating polymers push the more easily penetrating ones into nanosize channels in excess of their bath concentration. All three channels exhibited forced partitioning that could be understood conceptually as well as quantitatively within a “polymers-pushing-polymers” model, allowing good estimates for the size-dependent pore penetration energy differences. As a result of our work, beyond proof of concept, forced partitioning in cells can now be recognized and used as a new tool in studies of molecule-specific transport and active osmotically regulated packaging. In particular, comparison of the theory with experiments has proven to be excellent for VDAC. Polymer partitioning data for the other two channels were consistent with theory if additional assumptions regarding the energy penalty of pore penetration are included.

However, because of the several implicit assumptions, including those that idealized channel geometry, it is reasonable to expect deviations from the theoretical predictions. The obtained results demonstrate that the general concept of “polymers-pushing-polymers” is helpful in understanding and quantification of concrete examples of size-dependent forced partitioning of polymers into protein clefts and nanopores, with the obvious consequences for interpretation of molecular recognition under crowding conditions.

## Progress in theoretical and experimental studies of the voltage-dependent anion channel of the outer mitochondrial membrane

Present understanding of molecular mechanisms of functioning of beta-barrel channels, such as VDAC, general and specific bacterial porins, and various toxin channels, is far behind the progress in the field of “conventional” highly selective ion channels. Specifically, mitochondrial channels constitute a separate class characterized by unique properties that distinguish them from other channels, including evolutionarily related bacterial porins. Mitochondrial channels are directly involved in regulation of the normal function of mitochondria and in metabolic changes in response to environmental challenges and different kinds of stress, such as apoptosis. For example, VDAC, the channel of the outer mitochondrial membrane, serves as a major pathway for metabolite exchange between the cytosol and mitochondria and thus controls a significant portion of outer-membrane permeability. Small ions and water-soluble mitochondrial metabolites, such as ATP and ADP, all cross the mitochondrial outer membrane through one pathway, the VDAC. Therefore, determination of the molecular basis of VDAC’s ion selectivity, metabolite permeability, and regulation is crucial to understanding its function and physiological role. Our recent progress in VDAC studies (Reference 3) demonstrates that the computational techniques not only complement experimental electrophysiological data but also lead to an a priori identification of binding sites for ATP or for cytosolic regulators of VDAC, thus connecting existing structures to the long-standing proposition that VDAC plays a crucial role in providing and regulating metabolite transport in and out of mitochondria. Using a very promising new computational technology based on the combination of 2-dimensional umbrella sampling simulations with the distributed replica-exchange protocol, we showed that ATP in the VDAC pore exhibits a surprisingly broad distribution of states. For the first time, our analysis accounted for the flexibility of ATP molecule, revealing 10 most probable structural clusters along the pore that define the structure and energetics of permeation pathways (Figure 2). Notably, one of the pathways can be associated with the highest possible ATP flux rates. It appears that, in a majority of cases, the rate-limiting step is dissociation of ATP from the alpha-helix of the VDAC N-terminus. Importantly, all basic residues in the VDAC’s N-terminus, which participate in formation of an ATP-binding site, were also found to bind to the acidic residues in the C-terminal tail of alpha-tubulin, a very efficient regulator of VDAC function. This conclusion is supported by our previous experiments and calculations, which show that ATP is excluded from the tubulin-blocked state of VDAC. Thus, the availability of the recently solved structures, our latest experimental data, and powerful state-of-the-art computational techniques, combined with modern analytical approaches, led to the breakthrough in our understanding of the relationship between VDAC function and structure.

## Physical theory of channel-facilitated transport

Physical theory of channel-facilitated transport gives us a set of rigorous tools for quantitative analysis of experimental findings. This year, we had extended our studies of entropic effects in transport problems. Whenever transport of particles takes place in the presence of three-dimensional non-uniform confining geometries, the description of the particle dynamics in terms of the one-dimensional Smoluchowski equation effectively introduces entropy potentials, which account for the variations in confinement



geometry along a particle's path. Such structures with varying confinement are ubiquitous in both technology and biology. Ion channels offer a class of probably the smallest structures in which the main concepts of confined diffusion are still applicable. One of our studies (Reference 4) addresses the range of validity of the reduction of axial diffusion in two-dimensional channels to the effective one-dimensional description in terms of the modified Fick-Jacobs equation. We demonstrated that such a reduction is applicable when the channel width variation rate does not exceed unity. In another study (Reference 5), we analyzed the diffusion of point particles in linearly corrugated two-dimensional channels. Such geometry allowed us to obtain an approximate analytical expression that gives the particle effective diffusivity as a function of the geometric parameters of the channel. To establish its accuracy and the range of applicability, we tested the expression against Brownian dynamics simulation results. The tests showed that the expression works very well for long channel corrugation periods, but fails when the period is not long enough compared with the minimum width of the channel. To address this deficiency, we proposed a simple empirical correction to the analytical expression: the "structure wavelength" correction. The resulting expression for the effective diffusivity proved to be in excellent agreement with the simulation results for all values of the channel corrugation period.

## Publications

1. Aksoyoglu MA, Podgornik R, Bezrukov SM, Gurnev PA, Muthukumar M, Parsegian VA. Size-dependent forced PEG partitioning into channels: VDAC, OmpC, and Alpha-Hemolysin. *Proc Natl Acad Sci USA* 2016 113:9003–9008.
2. Kasianowicz JJ, Bezrukov SM. On "Three decades of nanopore sequencing". *Nat Biotech* 2016 34:481-482.
3. Noskov SY, Rostovtseva TK, Chamberlin AC, Teijido O, Jiang W, Bezrukov SM. Current state of theoretical and experimental studies of the voltage-dependent anion channel (VDAC). *Biochim Biophys Acta* 2016 1858:1778-1790.
4. Berezhkovskii AM, Dagdug L, Bezrukov SM. Range of applicability of modified Fick-Jacobs equation in two dimensions. *J Chem Phys* 2015 143:164102.
5. Verdel R, Dagdug L, Berezhkovskii AM, Bezrukov SM. Unbiased diffusion in two-dimensional channels with corrugated walls. *J Chem Phys* 2016 144:084106.

## Collaborators

- Vicente M. Aguilera, PhD, *Universidad Jaume I, Castellón, Spain*
- Alphan Aksoyoglu, MS, *University of Massachusetts Amherst, Amherst, MA*
- Alexander M. Berezhkovskii, PhD, *Division of Computational Bioscience, CIT, NIH, Bethesda, MD*
- Susan K. Buchanan, PhD, *Laboratory of Molecular Biology, NIDDK, Bethesda, MD*
- Leonid V. Chernomordik, PhD, *Section on Membrane Biology, NICHD, Bethesda, MD*
- Leonardo Dagdug, PhD, *Universidad Autónoma Metropolitana-Iztapalapa, Mexico City, Mexico*
- David Hoogerheide, PhD, *National Institute of Standards and Technology, Gaithersburg, MD*
- Jennifer C. Lee, PhD, *Biochemistry and Biophysics Center, NHLBI, Bethesda*
- Ekaterina M. Nestorovich, PhD, *The Catholic University of America, Washington, DC*
- Sergei Y. Noskov, PhD, *University of Calgary, Calgary, Canada*
- Adrian Parsegian, PhD, *University of Massachusetts Amherst, Amherst, MA*
- Olga Protchenko, PhD, *Liver Diseases Branch, NIDDK, Bethesda, MD*

- Dan Sackett, PhD, *Section on Cell Biophysics, NICHD, Bethesda, MD*
- Gerhard Wagner, PhD, *Harvard Medical School, Cambridge, MA*
- Michael Weinrich, MD, *Director, National Center for Rehabilitation Research, NICHD, Bethesda, MD*
- David L. Worcester, PhD, *National Institute of Standards and Technology, Gaithersburg, MD*
- Joshua Zimmerberg, MD PhD, *Section on Cellular and Membrane Biophysics, NICHD, Bethesda, MD*

## Contact

For more information, email [bezrukov@helix.nih.gov](mailto:bezrukov@helix.nih.gov) or visit <http://smt.nichd.nih.gov>.

## Protein Sorting in the Endosomal-Lysosomal System

We investigate the molecular mechanisms by which transmembrane proteins (referred to as cargo) are sorted to different compartments of the endo-membrane system in eukaryotic cells. The system consists of an array of membrane-enclosed organelles including the endoplasmic reticulum (ER), the Golgi apparatus, the trans-Golgi network (TGN), endosomes, lysosomes, lysosome-related organelles (LROs) (e.g., melanosomes), and various domains of the plasma membrane in polarized cells (e.g., in epithelial cells and neurons). Transport of cargo between the compartments is mediated by carrier vesicles or tubules, which bud from a donor compartment, translocate through the cytoplasm, and eventually fuse with an acceptor compartment. Work in our laboratory focuses on the molecular machineries that mediate these processes, including (1) sorting signals and adaptor proteins that select cargo proteins for packaging into the transport carriers, (2) microtubule motors that drive movement of the transport carriers and other organelles through the cytoplasm, and (3) tethering factors that promote fusion of the transport carriers to acceptor compartments. We study the machineries in the context of different intracellular transport pathways, including endocytosis, recycling to the plasma membrane, retrograde transport from endosomes to the TGN, biogenesis of lysosomes and LROs, and polarized sorting in epithelial cells and neurons. We apply knowledge gained from this research to the elucidation of protein trafficking diseases such as the Hermansky-Pudlak syndrome (HPS), a pigmentation and bleeding disorder, and the MEDNIK syndrome, a neuro-cutaneous disorder. In addition, we study how the molecular mechanisms of protein transport are exploited by intracellular pathogens such as HIV-1.

### An AP-1/clathrin pathway for the sorting of transmembrane receptors to the somato-dendritic domain of hippocampal neurons

A major focus of research in our laboratory is on processes mediated by recognition of sorting signals in the cytosolic tails of transmembrane proteins by adaptor proteins (APs) that are components of protein coats (e.g., clathrin coats). Two types of sorting signal, referred to as tyrosine-based and dileucine-based, participate in various sorting events, including endocytosis,

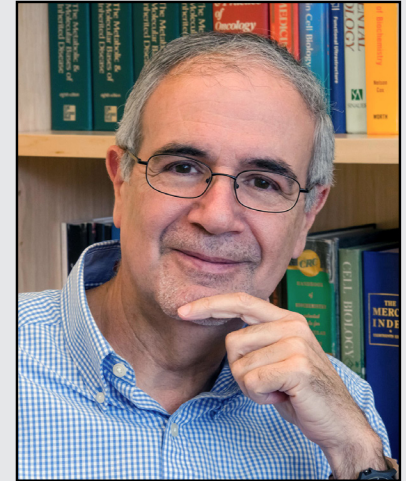

**Juan S. Bonifacino, PhD, Head,**  
*Section on Intracellular Protein Trafficking*

Rafael Mattera, PhD, *Staff Scientist*

Xiaolin Zhu, RN, *Technician*

Raffaella De Pace, PhD, *Visiting Fellow*

Atena Farkhondeh, PhD, *Visiting Fellow*

David Gershlick, PhD, *Visiting Fellow*

Carlos M. Guardia, PhD, *Visiting Fellow*

Rui Jia, PhD, *Visiting Fellow*

Tal Keren-Kaplan, PhD, *Visiting Fellow*

Sang-Yoon Park, PhD, *Visiting Fellow*

Jing Pu, PhD, *Visiting Fellow*

Amra Saric, PhD, *Visiting Fellow*

David Kolin, BS, *Postbaccalaureate Student*

Jeffrey Mercurio, BS,  
*Postbaccalaureate Student*

Abby Moskowitz, BS,  
*Postbaccalaureate Student*

transport to lysosomes and melanosomes, and sorting to the basolateral surface of polarized epithelial cells. In recent years, we extended our studies to the role of signal-adaptor interactions in the process of polarized sorting in neurons. We found that many of these proteins are sorted to the somatodendritic domain by interaction of tyrosine-based or dileucine-based signals with the adaptor protein complex AP-1. More recently, in collaboration with Morten Nielsen, we found that the intracellular sorting receptor SorLA is sorted to the somatodendritic domain of neurons and the basolateral domain of polarized epithelial cells by virtue of an acidic cluster in its cytosolic tail that interacts with AP-1. Together with previous work, the findings establish the AP-1 complex as a global regulator of polarized sorting in different cell types. Defects in polarized sorting likely underlie the pathogenesis of several neuro-cutaneous disorders caused by mutation in sigma1 subunit isoforms, such as the MEDNIK syndrome (sigma1A), Fried/Pettigrew syndrome (sigma1B), and pustular psoriasis (sigma1C).

## Polarized organelle segregation in neurons by differential interactions with microtubule motors

Polarized sorting of newly synthesized proteins to the somato-dendritic and axonal domains of neurons occurs by selective incorporation into distinct populations of vesicular transport carriers. We recently found that segregation of the carriers to their corresponding neuronal compartments occurs at a region in the axon hillock named the pre-axonal exclusion zone (PAEZ) through coupling to different microtubule motors. We also discovered a chain of interactors, including the small GTPase Rab5, the FHF complex, and dynein-

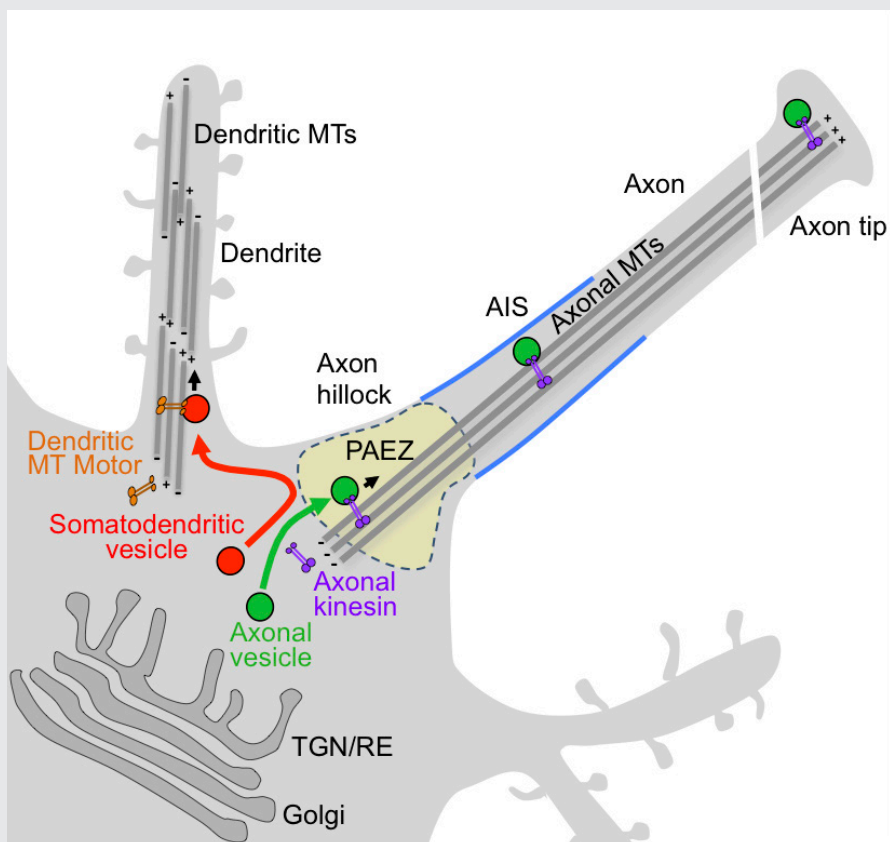

FIGURE 1. Sorting of somato-dendritic and axonal vesicles at the pre-axonal exclusion zone (PAEZ)

dynactin, that retrieves somatodendritic proteins from the axon, thus contributing to their somatodendritic distribution at steady state.

## A role for AP-1 in sorting presenilin-2 to late endosomes and lysosomes

In collaboration with Wim Annaert, we demonstrated an additional role for the AP-1 complex in the sorting of a novel form of gamma-secretase to late endosomes and lysosomes. Gamma-secretases are a family of intramembrane-cleaving proteases involved in the pathogenesis of Alzheimer's disease. A sorting motif in the cytosolic tail of the presenilin-2 (PSEN2) subunit of gamma-secretase targets this enzyme to late endosomes and lysosomes. The motif is recognized in a phosphorylation-dependent manner by AP-1. PSEN2 selectively cleaves late endosomal/lysosomal-localized substrates and generates a prominent pool of longer, more pathogenic amyloid-beta peptide. The findings reveal potentially important roles for lysosome-generated amyloid-beta peptide in Alzheimer's disease.

## Biochemical and functional studies of AP-4

Another adaptor protein complex named AP-4 is a component of a non-clathrin coat involved in protein sorting at the TGN. Considerable interest in this complex has arisen from the recent discovery that mutations in each of its four subunits are the cause of a congenital intellectual disability and movement disorder in humans. We discovered that an accessory protein named tepsin interacts with AP-4 via interaction of two phylogenetically conserved peptide motifs with the beta4 and epsilon ear domains of AP-4. The bivalency of the interactions increases the avidity of tepsin for AP-4 and may enable cross-linking of multiple AP-4 hetero-tetramers, thus contributing to the assembly of the AP-4 coat. The findings extend the paradigm of peptide-ear interactions, previously established for clathrin-AP-1/AP-2 coats, to a non-clathrin coat. Furthermore, in collaboration with Dennis Drayna, we identified rare sequence variants of the epsilon subunit of AP-4 in individuals with persistent developmental stuttering. We also demonstrated that AP-4 interacts with NAGPA, another protein previously linked to developmental stuttering. Our findings thus implicate deficits in intracellular trafficking in persistent stuttering.

## Identification of TSSC1 as a novel component of the endosomal retrieval machinery

Endosomes function as a hub for several protein sorting events, including retrograde transport to the TGN and recycling to the plasma membrane. These processes are mediated by tubular-vesicular carriers that bud from early endosomes and fuse with a corresponding acceptor compartment. We previously investigated the role of two multi-subunit tethering complexes named GARP and EARP, which participate in SNARE (soluble *N*-ethylmaleimide-sensitive-factor attachment receptor)-dependent fusion of endosome-derived carriers with the TGN and recycling endosomes, respectively. More recently, we discovered that a previously uncharacterized WD40/beta-propeller protein named TSSC1 is a specific interactor of both GARP and EARP and a novel component of the endosomal retrieval machinery. Interference with TSSC1 impairs both retrograde transport to the TGN and retrieval to the plasma membrane. The findings contribute to the understanding of the pathogenesis of progressive cerebello-cerebral atrophy type 2, a neurodegenerative disorder caused by mutations in the shared Vps53 subunit of GARP and EARP.

## Mechanisms of CD4 downregulation by HIV-1 Nef

Primate immunodeficiency viruses target helper T cells and macrophages/monocytes by binding of the viral envelope glycoprotein to a combination of CD4 and a chemokine receptor (CCR4 or CXCR5) on the surface

of the host cells. Strikingly, infection results in rapid and sustained downregulation of CD4 and, to a lesser extent, of the chemokine receptors. Downregulation of these viral co-receptors prevents superinfection, promotes virion release and interferes with the immune response, leading to the establishment of a robust infection. CD4 downregulation is so important to the life cycle of human immunodeficiency virus-1 (HIV-1) that two accessory proteins, Nef and Vpu, encoded by the viral genome, are devoted to this task. Indeed, Nef and Vpu are critical for the progression from infection to AIDS, a fact that is best illustrated by the existence of long-term non-progressors who are infected with HIV-1 strains bearing inactivating mutations in the genes encoding these proteins. Therefore, pharmacologic or biologic perturbation of Nef and/or Vpu has the potential to prevent the pathogenic effects of HIV-1. To date, however, this potential has not been realized, mainly because Nef and Vpu have no enzymatic activity and their mechanisms of action are insufficiently understood.

In previous work, we found that the HIV-1 accessory protein Nef connects surface CD4 to both the endocytic and lysosomal targeting machineries, leading to efficient and sustained removal of CD4 from host cells early during infection. The role of Nef in CD4 internalization involves an interaction with the AP-2 clathrin adaptor. Subsequent to induction of CD4 internalization by an AP-2/clathrin pathway, Nef promotes delivery of internalized CD4 to the multivesicular body pathway (MVB) for eventual degradation in lysosomes. In collaboration with Luis da Silva, we recently found that this targeting depends on a direct interaction of Nef with Alix/AIP1, a protein associated with the Endosomal Sorting Complexes Required for Transport (ESCRT) machinery, which assists with cargo recruitment and intra-luminal vesicle formation in MVBs. We showed that Nef interacts with both the Bro1 and V domains of Alix. Depletion of Alix or overexpression of the Alix V domain impaired lysosomal degradation of CD4 induced by Nef. In contrast, V-domain overexpression did not prevent cell-surface removal of CD4 by Nef or protein targeting to the canonical, ubiquitination-dependent MVB pathway. We also showed that the Nef-Alix interaction occurs in late endosomes that are enriched in internalized CD4. Together, the results indicated that Alix functions as an adaptor for the ESCRT-dependent, ubiquitin-independent targeting of CD4 to the MVB pathway induced by Nef.

## Additional Funding

- Intramural AIDS Targeted Antiviral Program (IATAP)

## Publications

1. Farias GG, Guardia CM, Britt DJ, Guo X, Bonifacino JS. Sorting of dendritic and axonal vesicles at the pre-axonal exclusion zone. *Cell Rep* 2015 10:1221-1232.
2. Pu J, Schindler C, Jia R, Jarnik M, Backlund P, Bonifacino JS. BORC, a multisubunit complex that regulates lysosome positioning. *Dev Cell* 2015 33:176-188.
3. Schindler C, Chen Y, Pu J, Guo X, Bonifacino JS. EARP is a multisubunit tethering complex involved in endocytic recycling. *Nat Cell Biol* 2015 17:639-650.
4. Mattera R, Guardia CM, Sidhu SS, Bonifacino JS. Bivalent motif-ear interactions mediate the association of the accessory protein tepsin with the AP-4 adaptor complex. *J Biol Chem* 2015 290:30736-30749.
5. Sannerud R, Esselens C, Ejsmont P, Mattera R, Rochin L, Tharkeshwar AK, De Baets G, De Wever V, Habets R, Baert V, Vermeire W, Michiels C, Groot AJ, Wouters R, Dillen K, Vints K, Baatsen P, Munck S, Derua R, Waelkens E, Basi GS, Mercken M, Vooijs M, Bollen M, Schymkowitz J, Rousseau F, Bonifacino JS, Van Niel

- G, De Strooper B, Annaert W. Restricted location of PSEN2/gamma-secretase determines substrate specificity and generates an intracellular Abeta pool. *Cell* 2016 166:193-208.
6. Gershlick DC, Schindler C, Chen Y, Bonifacino JS. TSSC1 is novel component of the endosomal retrieval machinery. *Mol Biol Cell* 2016 27:2867-2878.
  7. Guo X, Farías GG, Mattera R, Bonifacino JS. Rab5 and its effector FHF contribute to neuronal polarity through dynein-dependent retrieval of somatodendritic proteins from the axon. *Proc Natl Acad Sci USA* 2016 113:E5318-5327.

## Collaborators

- Wim Annaert, PhD, *VIB Center for the Biology of Disease, Katholieke Universiteit, Leuven, Belgium*
- Luis L. P. da Silva, PhD, *Universidade de São Paulo, São Paulo, Brazil*
- Dennis Drayna, PhD, *Section on Genetics of Communication Disorders, NIDCD, Bethesda, MD*
- Eric O. Freed, PhD, *HIV Drug Resistance Program, Center for Cancer Research, NCI, Frederick, MD*
- Aitor Hierro, PhD, *CIC-bioGUNE, Bilbao, Spain*
- Morten S. Nielsen, PhD, *Aarhus Universitet, Aarhus, Denmark*
- Abdul Waheed, PhD, *Retroviral Replication Laboratory, Center for Cancer Research, NCI, Frederick, MD*

## Contact

For more information, email [bonifacinoj@helix.nih.gov](mailto:bonifacinoj@helix.nih.gov) or visit <https://irp.nih.gov/pi/juan-bonifacino>.

## Child and Family Development Across the First Three Decades

The Child and Family Research (CFR) Section investigates dispositional, experiential, and environmental factors that contribute to physical, mental, emotional, and social development in human beings across the first three decades of life. The research goals of the CFR are to describe, analyze, and assess (1) the capabilities and proclivities of developing children and youth, including their physiological functioning, perceptual and cognitive abilities, emotional and social growth, and interactional styles; (2) the nature and consequences of interactions within the family and the social world for offspring and parents; and (3) influences on development of children's exposure to and interactions with the natural and designed environments.

The CFR pursues two integrated multi-age, multi-informant, multi-variate, and multi-cultural research programs that are supplemented by a variety of ancillary investigations. The research programs represent an en bloc effort. The first includes a prospective longitudinal study designed to explore several aspects of child development in the context of major socio-demographic comparisons. As a part of this program, investigations in developmental neuroscience (cardiac function and EEG in psychological development; eye-tracking, perception, and cognition; and categorization) and behavioral pediatrics (developmental sequelae of cancer in infancy; children's understanding and coping with medical experiences; parental depression, preterm birth, deaf culture and child development; and behavior problems in adolescence) are carried out, addressing questions at the interface of child development, biology, and health.

The second CFR program broadens the perspectives of the first to encompass cultural influences on development within the same basic longitudinal framework. Cultural study sites include Argentina, Belgium, Brazil, Cameroon, Chile, England, France, Israel, Italy, Japan, Kenya, Peru, and the Republic of South Korea, as well as the United States; in all places, intra-cultural as well as cross-cultural comparisons are pursued. In this effort, the CFR collaborates with the Parenting Across Cultures project, which studies 8- to-16-year-olds and their families longitudinally in 11 cultural groups in nine countries and makes use of the UNICEF Multiple Indicator Cluster



**Marc H. Bornstein, PhD, Head,**  
*Child and Family Research  
Section*

Clay Mash, PhD, *Psychologist*

Joan Suwalsky, MS, *Research  
Psychologist*

Charlene Hendricks, PhD,  
*Statistician*

Diane Putnick, PhD, *Statistician*

Sarah Racz, PhD, *Postdoctoral  
Fellow*

Chun-Shin Hahn, PhD, *Contractor*



Survey of about 50 low- and middle-income countries globally. Overall, CFR research topics concern the origins, status, and development of psychological constructs, structures, functions, and processes across the first three decades of life; effects of child characteristics and activities on parents; and the meaning of variations in parenting and in the family across a wide variety of socio-demographic and cultural groups. The ultimate aims of both CFR research programs are to promote aware, fit, and motivated children who will, it is hoped, eventually grow into knowledgeable, healthy, happy, and productive adults.

## The child, the parent, and the family across the first three decades

Command of language is a cornerstone of development and necessary for successful adjustment. A four-wave 10-year prospective longitudinal study evaluated stability of core language skill in 1,780 children in varying categories of biological and social risk. Structural equation modeling supported loadings of diverse measures of child language on single latent variables of core language skill at 15 and 25 months and 5 and 11 years. Core language skill was stable over the first decade of life; we obtained significant and comparable stability coefficients for children with diverse biological and social risks, including poor health, welfare status, teen motherhood, ethnicity, gender, birth order, and families that changed in income and maternal education over the study period; stability in language was strong, even accounting for child nonverbal intelligence and social competence, maternal education and language, and the family home environment.

Separation from parents in adolescence is normative and a prerequisite for healthy functioning in adulthood, while adolescent detachment from parents, a radical and developmentally premature emotional distancing, is linked to unhealthy functioning in adulthood. Peer relationships may play a role in how adolescents separate and/or detach from their parents. Using a latent variable approach, we examined how, among 190 14-year-olds, adolescents' separation and detachment from mother related to adolescent peer relationships and whether peer relationships moderated how separation and detachment related to adolescent internalizing and externalizing behavior problems. Detachment from parents was associated with less positive peer relationships and more internalizing and externalizing problems. Positive peer relationships sharply attenuated relations between detachment and higher internalizing and externalizing problems. Healthy separation from parents was unrelated to peer relationships, internalizing, and externalizing. Our findings indicate that peers are an important but often unavailable resource for detached adolescents.

Temperament in infancy, defined as individual differences in attentional, motor, and emotional reactivity, is expected to remain relatively constant over development, although it can change in response to the environment. Two studies focused on the child's first year and considered infant age, gender, birth order, term status, and socio-economic status (SES) as moderators of temperament stability. Study 1 consisted of 73 mothers of firstborn term girls and boys at 2, 5, and 13 months of age. Study 2 consisted of 335 mothers of infants of different gender, birth order, term status, and SES at 6 and 12 months. At all time-points across both studies, different aspects of temperament organized into positive and negative affectivity factors. Infant temperament proved stable and robust across gender, birth order, term status, and SES. Stability coefficients for temperament factors and scales were medium to large for shorter (less than nine-month) inter-assessment intervals and small to medium for longer (greater than 10-month) intervals. However, the range of shared variance in average stability between adjacent time-points across both studies was only 20–29%, suggesting that 71–80% of the variance in temperament at a later time point was not explained

by temperament at an earlier time point, thus indicating a great deal of instability in temperament. Interventions to adjust infant temperament could be beneficial because temperament affects children's interactions with the world, colors how they interpret their experiences, shapes how they compare themselves with others, and the manner in which others perceive and respond to them.

## Child development and parenting in multicultural perspective

UNICEF estimates that one in six children aged 5–14 years is involved in child labor. Child labor may be a barrier to achieving universal education because poor families need children to work, which prevents school attendance. However, the empirical link between child labor and schooling has been incompletely documented. We explored relations of child labor with school enrollment in 186,795 7- to 14-year-old children in 30 low- and middle-income countries. We controlled for child age and caregiver education and examined moderating effects of country and child gender. At the country level, a strong significant relation emerged between child labor and school enrollment. Relations between child labor and schooling at the country level are suggestive, but they do not help to explain whether child labor is consistently related to schooling at the family level. Aggregating across boys and girls at the family level, child labor was associated with a lower probability of school enrollment in 15 countries. Although most countries in this study have policies to provide free education, their implementation may be incomplete because of inadequate funding, infrastructure, and availability of qualified teachers. Programs to promote universal education and reduce child labor in each country will likely need to be tailored to specific country, neighborhood, and family conditions.

Adult appropriate responding to infant signals is vital to healthy child development. We investigated how infant crying, compared with infant laughing or adult crying, captures adults' brain resources in a sample of nulliparous women and men, e.g., the effects of different sounds on cerebral activation of the medial prefrontal cortex and posterior cingulate cortex of the default mode network (DMN) and reaction times (RTs) while listeners engaged in self-referential decision and syllabic counting tasks, which, respectively, require the activation or deactivation of the DMN. In women, infant crying deactivated the DMN during the self-referential decision task; in men, female adult crying interfered with the DMN during the syllabic counting task. The findings point to different brain processes underlying responsiveness to crying in women and men and show that cerebral activation is modulated by situational contexts in which crying occurs.

For decades, the United Nations has recognized that physical growth and survival of young girls and boys in developing countries are compromised, although the role that gender plays in growth outcomes and mortality remains unclear. We assessed differences between girls and boys in growth in 139,614 children under age five, and child mortality of girls and boys collected from 226,798 childbearing women between the ages of 15 and 49 in 34 developing countries. Where there were gender differences in height for age (stunting), weight for age (underweight), weight for height (wasting), and mortality, boys were at a greater disadvantage than girls. Further, correlations of gender effect sizes with the HDI (Human Development Index) indicated that boys were at a greater disadvantage than girls in countries with fewer socioeconomic resources. In sum, the disadvantages in growth and mortality found for boys reflect known biological/genetic differences in susceptibility to environmental conditions. The genetic advantage present for girls tends to be less protective with respect to health conditions that reflect transient circumstances and discretionary behavior. Achievement of Millennium Development Goals pertaining to child health and equity will require continued efforts to modernize community infrastructure and health services and increase economic well-being.

## Additional Funding

- Bench to Bedside Award NHD16004-001: "Mirror neuron network dysfunction as an early biomarker of neurodevelopment," funded by Office of Behavioral & Social Sciences Research (OBSSR) 2016; ongoing.
- Interagency Agreement #CPSC-I-14-0016: "Interagency Agreement between the U.S. Consumer Product Safety Commission and the National Institute of Child Health and Human Development", 2015; ongoing.

## Publications

1. Jager J, Yuen CX, Putnick DL, Hendricks D, Bornstein MH. Adolescent-peer relationships, separation and detachment from parents, and internalizing and externalizing behaviors: linkages and interactions. *J Early Adolescence* 2015 35:511-537.
2. Bornstein MH, Putnick DL, Garstein MA, Hahn C-S, Auestad N, O'Connor DL. Infant temperament: stability of by age, gender, birth order, term status, and socioeconomic status. *Child Dev* 2015 86:844-863.
3. Rigo P, De Pisapia N, Bornstein MH, Putnick D, Serra M, Esposito G, Venuti P. Brain processes in women and men in response to emotive sounds. *Soc Neurosci* 2016; Epub ahead of print.
4. Bornstein MH, Putnick DL, Bradley RH, Deater-Deckard K, Lansford JE. Gender in low- and middle-income countries: introduction. *Monogr Soc Res Child Dev* 2016 81:1-144.
5. Bornstein MH, Hahn CS, Putnick DL. Stability of core language skill across the first decade of life in children at biological and social risk. *J Child Psychol Psychiatry* 2016 57(12):1434-1443.

## Collaborators

- Martha E. Arterberry, PhD, *Colby College, Waterville, ME*
- Roger Bakeman, PhD, *University of Georgia, Athens, GA*
- Erin Barker, PhD, *Concordia University, Montreal, Quebec, Canada*
- Yvonne Bohr, PhD, *York University, Toronto, Canada*
- Robert Bradley, PhD, *Arizona State University, Phoenix, AZ*
- Laura Caulfield, PhD, *The Johns Hopkins University, Baltimore, MD*
- Linda Cote, PhD, *Marymount University, Arlington, VA*
- Kirby Deater-Deckard, PhD, *Virginia Tech, Blacksburg, VA*
- Rodolfo de Castro Ribas, Jr, PhD, *Universidade Federal do Rio de Janeiro, Rio de Janeiro, Brazil*
- Annick De Houwer, PhD, *Universität Erfurt, Erfurt, Germany*
- Nicola De Pisapia, PhD, *Univesità degli Studi di Trento, Rovereto, Italy*
- Hirokazu Doi, PhD, *University of Nagasaki, Nagasaki, Japan*
- Xiaoxia Du, PhD, *East China Normal University, Shanghai, China*
- Gianluca Esposito, PhD, *RIKEN Brain Science Institute, Saitama, Japan*
- Celia Galperín, PhD, *Universidad de Belgrano, Buenos Aires, Argentina*
- Merideth Gattis, PhD, *Cardiff University, Cardiff, United Kingdom*
- Samuel Greiff, PhD, *Institute of Cognitive Science and Assessment, Luxembourg, Belgium*
- Derya Güngör, PhD, *Katholieke Universiteit Leuven, Leuven, Belgium*
- Chun-Shin Hahn, PhD, *Contractor*
- David W. Haley, PhD, *University of Toronto Scarborough, Scarborough, Canada*
- Justin Jager, PhD, *Arizona State University, Phoenix, AZ*
- Celestine Kish, MSc, *Consumer Product Safety Commission, Rockville, MD*

- Jennifer E. Lansford, PhD, *Duke University, Durham, NC*
- Emiddia Longobardi, PhD, *Università di Roma La Sapienza, Rome, Italy*
- Sharona Maital, PhD, *University of Haifa, Haifa, Israel*
- Nanmathi Manian, PhD, *Westat, Inc., Rockville, MD*
- A. Bame Nsamennang, PhD, *The Institute of Human Sciences, Bamede, Cameroon*
- Liliana Pascual, PhD, *Universidad de Buenos Aires, Buenos Aires, Argentina*
- Rebecca Pearson, PhD, *University of Bristol, Bristol, United Kingdom*
- Marie-Germaine G. Pecheux, PhD, *Centre National de la Recherche Scientifique, Paris, France*
- Khalisa Phillips, EdM, PhD, *Consumer Product Safety Commission, Rockville, MD*
- David P. Pisoni, PhD, *Indiana University Bloomington, Bloomington, IN*
- Sara Scrimin, PhD, *Università degli Studi di Padova, Padua, Italy*
- Maria Lucia Seidl-de-Moura, PhD, *Universidade do Estado do Rio de Janeiro, Rio de Janeiro, Brazil*
- Vincenzo Paolo Senese, PhD, *Seconda Università degli Studi di Napoli, Caserta, Italy*
- Kazuyuki Shinohara, MD, *Nagasaki University, Nagasaki, Japan*
- Beate Sodian, PhD, *Ludwig-Maximilian-Universität, Munich, Germany*
- Alan L. Stein, MBBCh, *University of Oxford, Oxford, United Kingdom*
- Xueyun Su, PhD, *East China Normal University, Shanghai, China*
- Catherine Tamis-LeMonda, PhD, *New York University, New York, NY*
- Audrey Thurm, PhD, *Pediatric and Developmental Neuroscience Branch, NIMH, Bethesda, MD*
- Miguel Vega, PhD, *University of Santiago, Santiago, Chile*
- Paola Venuti, PhD, *Università degli Studi di Trento, Rovereto, Italy*
- Dieter Wolke, PhD, *University of Warwick, Coventry, United Kingdom*

## Contact

For more information, email [marc\\_h\\_bornstein@nih.gov](mailto:marc_h_bornstein@nih.gov) or visit <http://www.cfr.nichd.nih.gov>.

## Neuregulin–ErbB Signaling in Neuronal Development and Psychiatric Disorders

Failure of cortical microcircuits to properly regulate excitatory/inhibitory (EI) balance is a key feature in the etiology of several developmental psychiatric disorders and neurological diseases, such as schizophrenia, autism, ADHD, and epilepsy. EI balance is important to synchronize the firing pattern of local neuron ensembles, and its dysregulation can degrade cognitive functions and, in extreme cases, result in epileptiform activity. Network activity, in particular oscillatory activity in the gamma-frequency range (30–80 Hz), is altered in psychiatric disorders and may account for their cognitive and behavioral symptoms. We are interested in how Neuregulin and its receptor ErbB4, which are both genetically linked to psychiatric disorders, function in rodents in an activity-dependent fashion (i.e., experience) in the developing brain to regulate synaptic plasticity, neuronal network activity, and behaviors that model features of psychiatric disorders. We identified a functional interaction among Neuregulin/ErbB4, GABAergic, and dopamine signaling in GABAergic interneurons that is critical for understanding how Neuregulin can regulate EI balance and synchronous activity in neuronal networks, two processes that are important for cognitive functions altered in psychiatric disorders.

Our earlier studies demonstrated that, in the hippocampus and neocortex, expression of ErbB4, the major Neuregulin neuronal receptor, is restricted to GABAergic interneurons, particularly the parvalbumin-positive (Pv+) fast-spiking interneurons, which are critically important for modulating gamma oscillation induction and strength (i.e., power). Using genetically targeted mouse mutant models, we went on to show that Neuregulin–ErbB4 signaling regulates synaptic plasticity, neuronal network activity (i.e., gamma oscillations), and behaviors associated with psychiatric disorders. More recently, our group has been investigating other aspects of Neuregulin expression throughout the brain, its processing in response to neuronal activity, and its function in distinct neuronal populations of the developing and maturing nervous system. To achieve these goals, we are using a combination of techniques, including electrophysiological recordings in acute brain slices prepared from normal and genetically altered mice, multi-electrode field recordings from brains of freely moving rats, reverse-microdialysis neurochemistry, confocal fluorescence microscopy in



**Andres Buonanno, PhD,**  
*Head, Section on Molecular  
Neurobiology*

Detlef Vullhorst, PhD, *Staff  
Scientist*

Irina Karavanova, PhD, *Research  
Assistant*

Tanveer Ahmed, PhD, *Postdoctoral  
Fellow*

Lalitha Kurada, PhD, *Postdoctoral  
Fellow*

Miguel Skirzewski, PhD,  
*Postdoctoral Fellow*

Larissa Erben, MS, *Graduate  
Student*

fixed and live tissue, proteomics analyses, and behavioral testing. The ultimate goal of this multi-disciplinary approach is to generate holistic models to investigate the developmental impact of genes that modulate EI balance and neuronal network activity and that consequently affect behaviors and cognitive functions altered in psychiatric disorders.

## Subcellular distribution of Neuregulin isoforms in central neurons

Numerous Neuregulins (NRGs) are generated by four different genes (*NRG1-NRG4*), distinct promoters (NRG1 types I, II and III), and alternative splicing, but the functional significance of this evolutionarily conserved diversity has, for over two decades, remained poorly understood. Our recent studies reveal that NRGs can be categorized by their distinct transmembrane topologies, which impart fundamentally different subcellular trafficking properties. As discussed in more detail in the sections below, NRGs whose pro-forms contain a single-pass transmembrane domain (TMD), such as NRG1 (types I and II) and NRG2, target the cell-body plasma membrane, where they accumulate at specialized contact sites with the underlying endoplasmic reticulum. Their ectodomains are cleaved by sheddases in an NMDA receptor activity-dependent manner

**FIGURE 1. Transmembrane topology of unprocessed pro-NRGs determines their neuronal subcellular targeting and processing in central neurons.**

A. Single-pass NRGs accumulate at subsurface cistern (SSC)-type ER-PM contact sites on the cell body and proximal dendrites to promote local NRG-ErbB signaling, whereas dual-pass NRGs accumulate on axons and axon terminals to drive long-range signaling.

B. Single-pass NRGs are trafficked through the secretory pathway as unprocessed pro-forms and accumulate at SSC-type ER-PM contact sites. Ectodomain shedding in response to glutamate signaling via NMDA receptors occurs at the plasma membrane at the neuronal cell surface. By contrast, unprocessed dual-pass NRGs are retained in the Golgi, and intracellular BACE (beta-secretase) processing releases the amino-terminal proteolytic fragment and enables anterograde transport into axons.

Both single- and dual-pass NRGs are processed by gamma-secretase to release carboxyl-terminal proteolytic fragments that can “back signal” to acutely regulate TRPV and alpha7-containing nACh receptors in axons (Hancock ML *et al. J Cell Biol* 2008;181:511; Canetta SE *et al. PLoS One* 2011;6:e2510) and gene expression in the nucleus (Bao J *et al. J Cell Biol* 2003;161:1133; Bao J *et al. Nat Neurosci* 2004;7:1250).

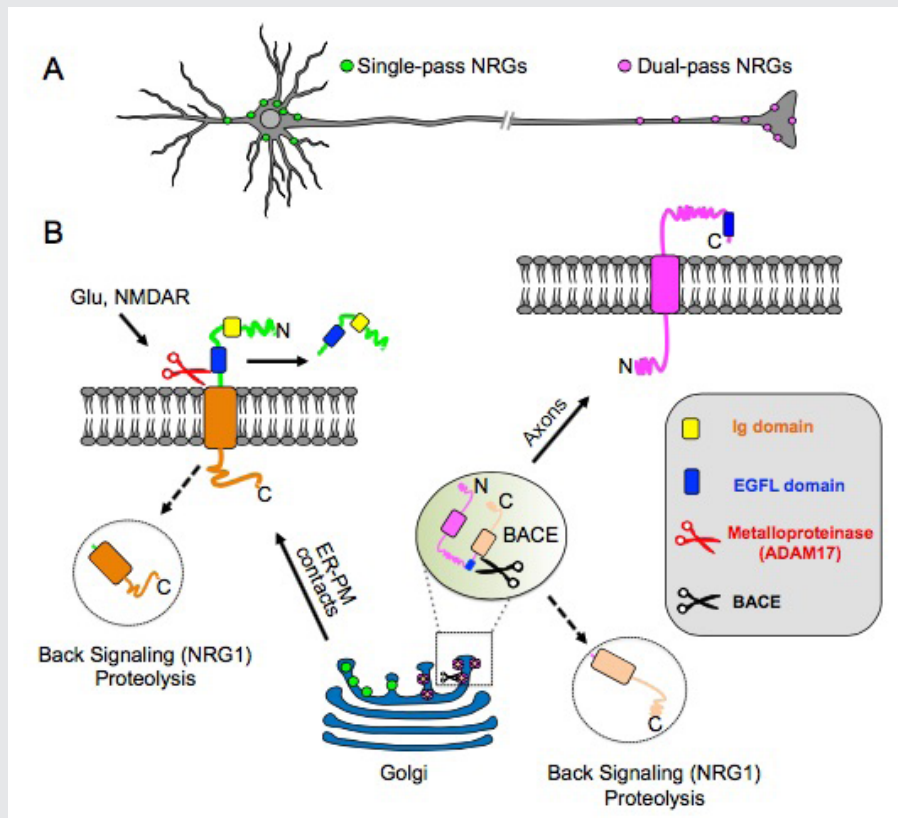

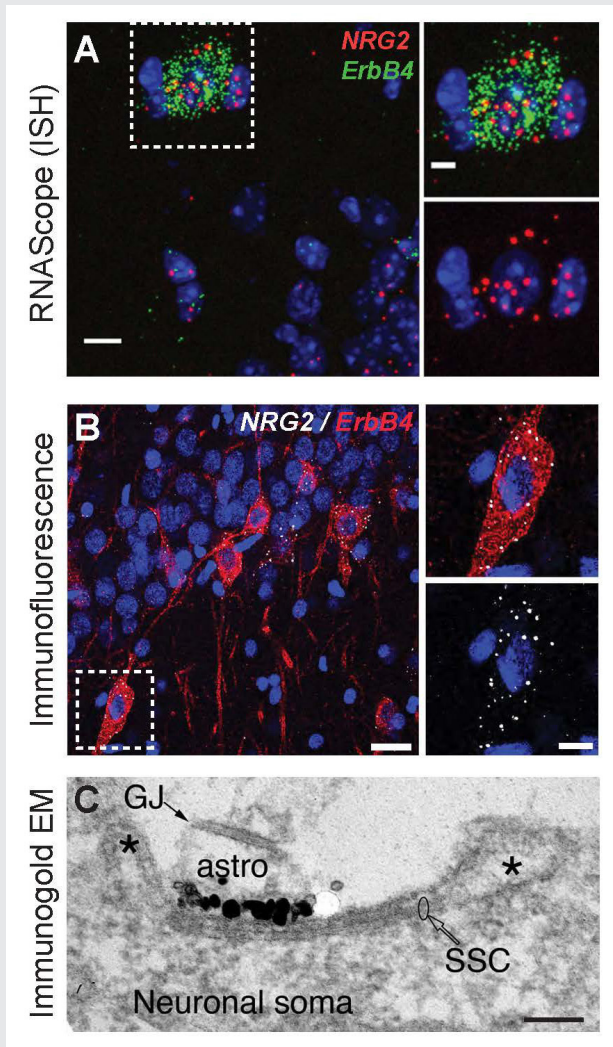

**FIGURE 2.** Neuregulin-2 is expressed in ErbB4-positive GABAergic interneurons and accumulates at SSCs.

A. Double fluorescence *in situ* hybridization (ISH) of NRG2/Gad67 and NRG2/ErbB4 in the mouse *stratum oriens* of CA1.

B. NRG2 immunoreactivity in ErbB4<sup>+</sup> interneurons in rat CA1 *strata pyramidale* and *radiatum*.

C. Silver-enhanced immunogold EM of a DIV 35 hippocampal neuron with a patch of concentrated label for NRG2 at the plasma membrane atop intracellular membrane stacks characteristic of SSCs.

and are then shed to signal in paracrine or autocrine fashion. Contrary to prior studies reporting NRG3 as a single-pass type I TMD protein, our analysis revealed that NRG3 is a dual-pass TMD protein. Interestingly, we found that, by contrast to the single-pass TMD NRGs, dual-pass NRG3 and NRG1 [type III; cysteine-rich domain (CRD)] are instead targeted to axons where they signal in juxtacrine mode (see Figure 1 for summary). The findings reveal a previously unknown functional relationship between membrane topology and subcellular targeting and suggest that single- and dual-pass TMD NRGs regulate neuronal functions in fundamentally different ways (Ahmed T, Vullhorst D *et al. J Neurosci*, in review). This work was supported by a Director's Investigator Award.

## Unprocessed proNRG2 accumulates on top of subsurface cisterns, and its processing and shedding are regulated by NMDA receptor activity.

We found that proNRG2 localizes on top of subsurface cisterns (SSCs), a site of endoplasmic reticulum-plasma membrane junctions, where it accumulates at the center of doughnut-shaped Kv2.1 (a voltage-

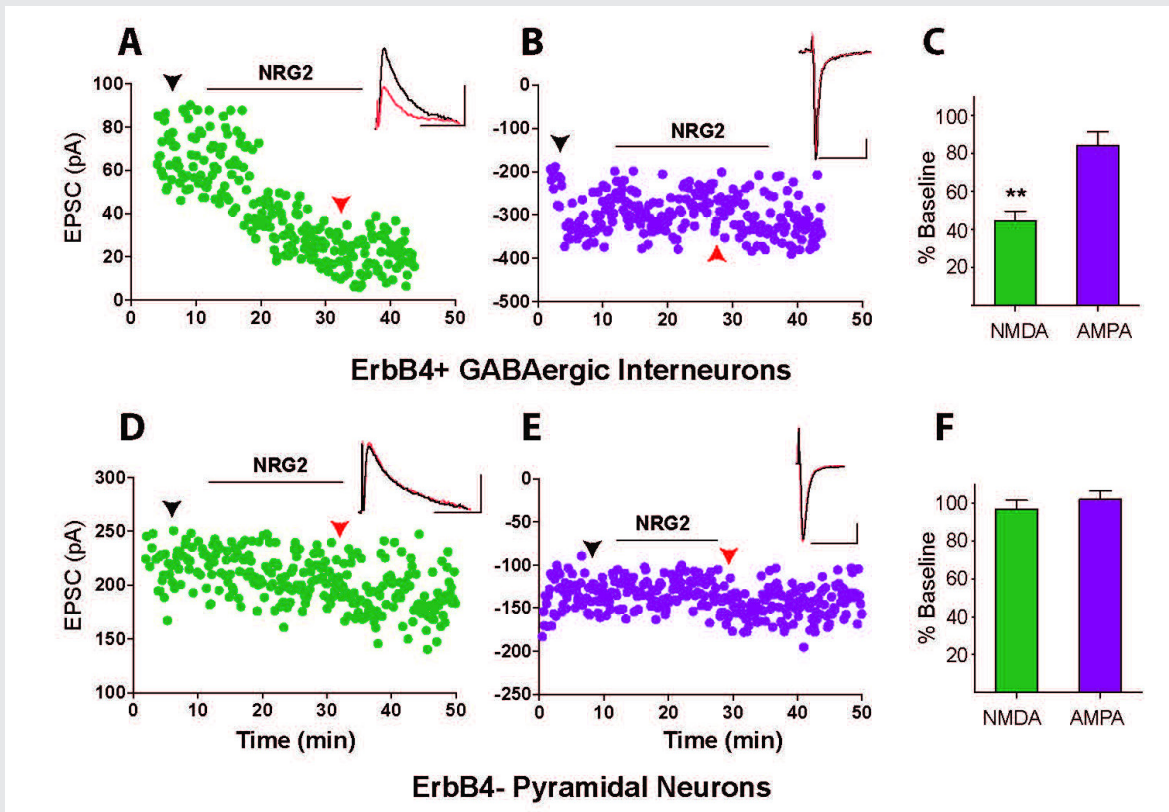
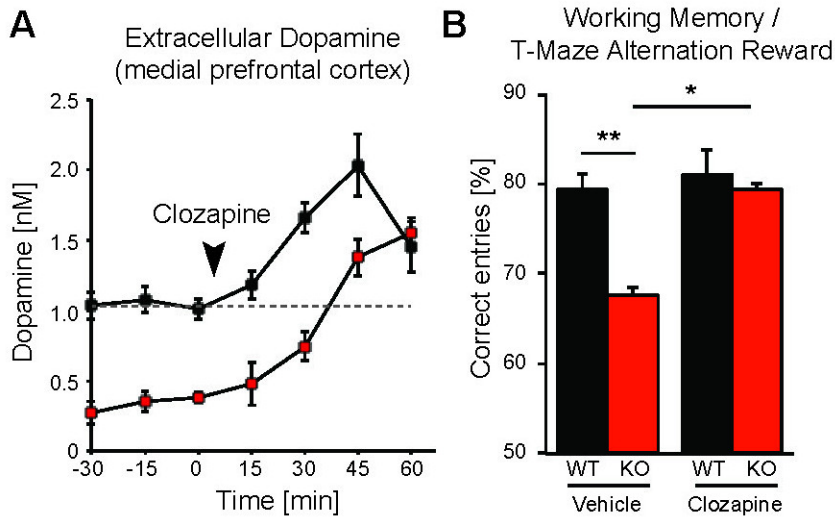

FIGURE 3. Neuregulin-2 selectively reduces NMDAR currents, but not AMPAR currents, in GABAergic interneurons.

A and B. Representative scatter plots of NMDAR- and AMPAR-mediated evoked EPSCs recorded from an ErbB4-positive GABAergic interneuron and (D and E) recorded from a pyramidal neuron. C and F. Summary graphs of NRG2 effects on NMDA and AMPA evoked excitatory postsynaptic currents (eEPSCs). Data normalized to baseline.

gated potassium channel) clusters at the edges of SSCs (Figure 2). Interestingly, treatment of neuronal cultures with glutamate or *N*-methyl-D-aspartate (NMDA) causes the rapid dispersal of both proteins from the SSC and processing of proNRG2 by sheddases to release the signaling-competent NRG2. We wished to determine the function of released NRG2 from GABAergic interneurons, which are known to express the ErbB4 receptor. In collaboration with Sanford Markey's group, we used ErbB4 immunoprecipitation from the soluble fraction of metabolically active synaptosomes followed by LC/MS/MS (liquid chromatography/tandem mass spectrometry) to characterize the ErbB4 proteome. Using this approach, we identified the GluN2B subunit of the NMDA receptor (NMDAR) as an ErbB4-interacting protein. We confirmed the interaction in cultured hippocampal neurons, where NRG2 treatment was shown to enhance the internalization of GluN2B-containing, but not GluN2A-containing, NMDARs (Figure 3). Consistent with this observation, we found that NRG2 also caused a dramatic reduction of whole-cell NMDAR currents in dissociated hippocampal ErbB4-positive interneurons, but not in ErbB4-negative glutamatergic neurons. Lastly, using whole-cell voltage-clamp recordings in acute medial prefrontal cortical slices, we found that NRG2 selectively reduced NMDAR synaptic currents (EPSCs), but not AMPAR EPSCs, at glutamatergic synapses onto GABAergic interneurons. The results are consistent with the idea that the bidirectional





**FIGURE 4.** Administration of antipsychotic clozapine restores dopamine levels in the pre-frontal cortex of Neuregulin-2 knockout mice and improves performance on a cognitive task.

A. Extracellular dopamine levels in the mPFC of *Nrg2* knockout (KO) mice and wild-type (WT) littermates before and after clozapine injection (arrowhead). B. Poorer performance by *Nrg2* KO mice in a T-maze reward alternation task than by WT littermates (left) can be restored by clozapine treatment (right).

signaling between NRG2/ErbB4 and NMDAR activity can play a major role in modulating the activity of GABAergic neurons and cortical E/I balance (Reference 1).

## Neuregulin-2 ablation results in dopamine dysregulation and severe behavioral phenotypes relevant to psychiatric disorders.

While the neurophysiological and behavioral phenotypes of *Nrg1*-mutant mice have been investigated extensively, little is known about the function of NRG2 (see above), the closest NRG1 homolog. We found that NRG2 expression in the adult rodent brain does not fully overlap with NRG1 and is more extensive than originally reported, including expression in the striatum and medial prefrontal cortex (mPFC). We therefore generated *Nrg2* knockout (KO) mice to study the homolog's function. *Nrg2* KO mice have elevated extracellular dopamine levels in the dorsal striatum but reduced levels in the mPFC, similar to schizophrenia subjects. *Nrg2* KOs also performed abnormally in a battery of behavioral tasks relevant to psychiatric disorders. The mutant mice exhibit hyperactivity in the open field, hypersensitivity to amphetamine, deficits in prepulse inhibition, reduced anxiety-like behavior in the elevated plus-maze, and antisocial behavior. Acute administration of clozapine (1mg/kg) increased the concentration of mPFC dopamine and improved performance in the T-maze alteration reward task (Figure 4). We also demonstrated that, in *Nrg2* KOs, NMDA receptor synaptic currents are augmented at hippocampal glutamatergic synapses and more sensitive to ifenprodil, indicating an increased contribution of GluN2B-containing NMDARs (Yan *et al. Mol Psychiatry*, in review). Our findings reveal a novel role for NRG2 in the modulation of behaviors relevant to the core symptoms of schizophrenia.

## Analysis of ErbB4 function in mice harboring targeted mutations in GABAergic and dopaminergic neurons

Dysfunctional Neuregulin-ErbB4 signaling in the hippocampus, pre-frontal cortex (PFC), or striatum may contribute to alterations in dopamine (DA) function associated with several schizophrenia symptoms. Given

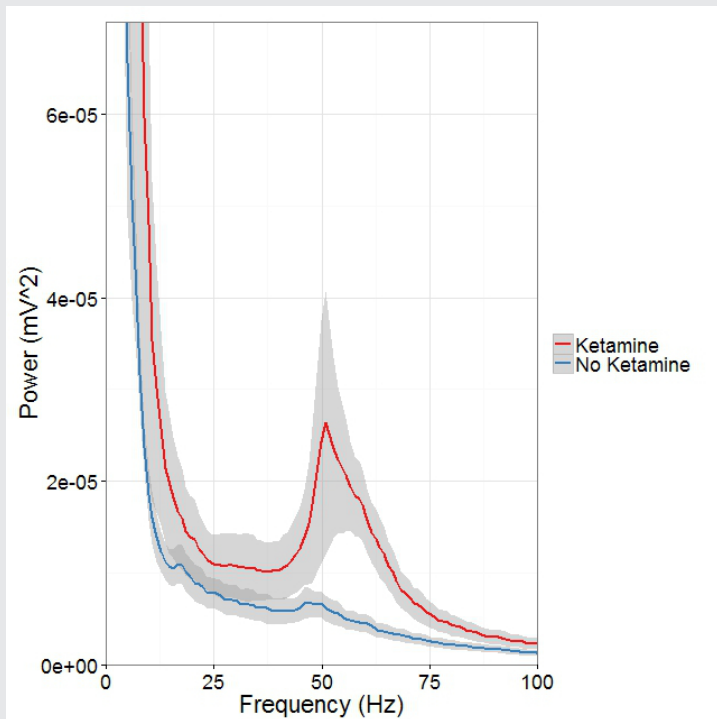

**FIGURE 5. Ketamine raises gamma (40–65Hz) frequency power in the medial prefrontal cortex (mPFC) during controlled movement.**

Multi-electrode recordings in the mPFC revealed an over three-fold increase in gamma (40–65Hz) frequency power while rats walked counter-clockwise at 9–10 revolutions per minute on a circular treadmill. Blue traces come from an epoch 30 minutes before ketamine administration and the red trace comes from epochs 15 minutes after ketamine administration.

that we showed NRG1 to acutely raise extracellular DA levels to regulate long-term potentiation (LTP) and gamma oscillations and that ErbB4 receptor expression is confined to GABAergic interneurons (cortex) and tyrosine hydroxylase positive (TH+) mesocortical DAergic neurons, we used genetic, biochemical, and behavioral approaches to measure DA function in the hippocampus, PFC, and striatum in mice harboring targeted mutations of *ErbB4* in either PV+ or TH+ neurons. Interestingly, we found that, in contrast to GABAergic neurons, *ErbB4* is highly expressed on the axons of DA neurons, suggesting that NRG/ErbB4 signaling may directly regulate the presynaptic function of these neurons. In collaboration with the laboratories of Susan Amara and Veronica Alvarez, we found that NRG regulates the increase in extracellular DA levels, at least in part, by DA transporter function. In contrast to mice harboring CNS-wide or GABAergic-restricted mutation of *ErbB4*, which show sensory-motor gating deficits and increases in motor activity, mice with ablation of *ErbB4* in TH+ neurons only manifest behavioral deficits in cognitive-related tasks, such as performance on the T-maze, Y-maze, and Barnes maze (Skirzewski *et al.*, in preparation). Our findings suggest that, in combination, direct effects of NRG/ErbB4 signaling in GABAergic and DAergic neurons regulate cortical circuits and DA homeostasis to affect numerous behaviors relevant to schizophrenia.

## Effects of ketamine on cortical gamma oscillations and the role of dopamine receptors

Mounting evidence suggests that gamma oscillations are atypically high at baseline in disorders that affect attention, such as schizophrenia and ADHD. Ketamine, an antagonist of the NMDAR, elicits psychosis and affects cognitive functions in healthy individuals that phenocopy schizophrenia. In collaboration with the lab of Judith Walters, we are using multi-electrode recordings from the medial prefrontal cortex

and dorsomedial thalamus of rats acutely treated with ketamine to analyze the effects of ketamine on gamma oscillations *in vivo* (Figure 5) and to determine whether and how D4 and ErbB4-targeting drugs can affect gamma oscillations in this rodent model with "face validity" for schizophrenia (Furth *et al. Psychopharmacology*, in review). We are also performing experiments to evaluate the effects of drugs targeting dopamine D4 receptors on attention and impulsivity behaviors in mice, using the five-choice serial-reaction time task (5CSRTT).

## Additional Funding

- Bench-to-Bedside Award (NHD15003-001-00001) "Selective Dopamine D4 Receptor-Targeting Compounds as Pro-Cognitive Drugs"
- NICHD DIR Director's Investigator Award (RRC# D-14-07). PI: Andres Buonanno; Co-PI: Juan Bonifacino. "Exploring the functional role of Neuregulin isoform diversity in CNS"

## Publications

1. Vullhorst D, Mitchell RM, Keating C, Roychowdhury S, Karavanova I, Tao-Cheng JH, Buonanno A. A negative feedback loop controls NMDA receptor function in cortical interneurons via neuregulin 2/ErbB4 signalling. *Nat Commun* 2015 6:7222.
2. Canfield K, Li J, Wilkins OM, Morrison MM, Ung M, Wells W, Williams CR, Liby KT, Vullhorst D, Buonanno A, Hu H, Schiff R, Cook RS, Kurokawa M. Receptor tyrosine kinase ERBB4 mediates acquired resistance to ERBB2 inhibitors in breast cancer cells. *Cell Cycle* 2015 14:648-655.

## Collaborators

- Veronica Alvarez, PhD, *Section on Neuronal Structure, NIAAA, Rockville, MD*
- Susan G. Amara, PhD, *Laboratory of Molecular and Cellular Neurobiology, NIMH, Bethesda, MD*
- Jung Hwa (Susan) Cheng, PhD, *EM Facility, NINDS, Bethesda, MD*
- Jennie Garcia-Olivares, PhD, *Laboratory of Molecular and Cellular Neurobiology, NIMH, Bethesda, MD*
- Idit Golani, MD, *Technion-Israel Institute of Technology, Haifa, Israel*
- Ilana Kremer, MD, *Technion-Israel Institute of Technology, Haifa, Israel*
- Sanford P. Markey, PhD, *Laboratory of Neurotoxicology, NIMH, Bethesda, MD*
- Alon Shamir, PhD, *Mazra Mental Health Center, Akko, Israel*
- Jung-Hoon Shin, PhD, *Section on Neuronal Structure, NIAAA, Rockville, MD*
- Judith R. Walters, PhD, *Experimental Therapeutics Branch, NINDS, Bethesda, MD*

## Contact

For more information, email [buonanno@mail.nih.gov](mailto:buonanno@mail.nih.gov) or visit <http://smn.nichd.nih.gov>.

## Neuronal Circuits Controlling Behavior: Genetic Analysis in Zebrafish

Our goal is to understand how, under diverse environmental contexts, the nervous system selects appropriate behavioral actions in a way that best satisfies internal motivational objectives. We use the zebrafish as a model because, in the larval stage, its brain exhibits the basic architecture of the vertebrate brain but is much less complex than the mammalian brain. Despite the relative simplicity of the nervous system, larvae have a sophisticated repertoire of sensory-guided and internally driven behaviors. Furthermore, the optical clarity of the embryo facilitates visualization of individual neurons and their manipulation with genetic techniques. Behavior in larvae is innate and therefore exhibits minimal variability between fish. Subtle alterations in behavior can therefore be robustly scored, making it possible to quickly assess the contribution of identified neurons to a variety of motor behaviors.

We focus on two aspects of behavioral regulation: the mechanisms by which sensory context regulates behavioral decisions (Reference 1) and pathways that sustain changes in behavioral state (Reference 2). In addition, we are developing a suite of genetic tools and behavioral assays to probe the nexus between neuronal function and behavior at single-cell resolution (References 3–5). The neuronal connections that allow the brain to integrate sensory and internal-state information are established through genetic interactions during development. We aim to identify genes and neurons that are required for the functional development of such connections. In vertebrates, neuronal circuits situated in the brainstem form the core of the locomotor control network and are responsible for balance, posture, motor control, and arousal. Accordingly, many neurological disorders stem from abnormal formation or function of brainstem circuits. Insights into the function of brainstem circuits in health and disease have come from genetic manipulation of neurons in zebrafish larvae in combination with computational analysis of larval behavior.

### Molecular identification of neurons that mediate prepulse inhibition

Startle responses are rapid reflexes that are triggered by sudden sensory stimuli; they help animals to defend against and escape from potentially threatening stimuli. In both fish and mammals, startle

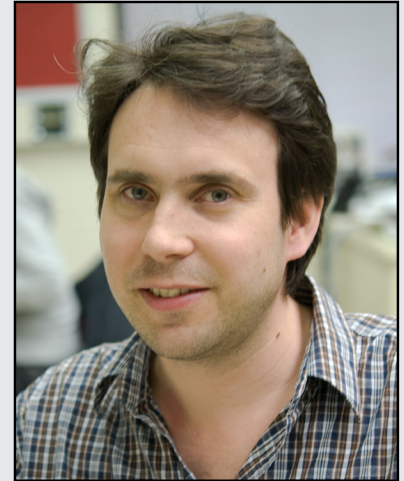

**Harold Burgess, PhD, Head,**  
*Section on Behavioral  
Neurogenetics*

Ashwin A. Bhandiwad, PhD,  
*Postdoctoral Fellow*

Eric J. Horstick, PhD, *Postdoctoral  
Fellow*

Abhignya Subedi, PhD,  
*Postdoctoral Fellow*

Kathryn M. Tabor, PhD,  
*Postdoctoral Fellow*

Gregory Marquart, BSc, *Graduate  
student*

Yared Bayleyen, BSc,  
*Postbaccalaureate Fellow*

Trevor S. Smith, BSc,  
*Postbaccalaureate Fellow*

Jennifer L. Strykowski, MSc,  
*Zebrafish Technician*

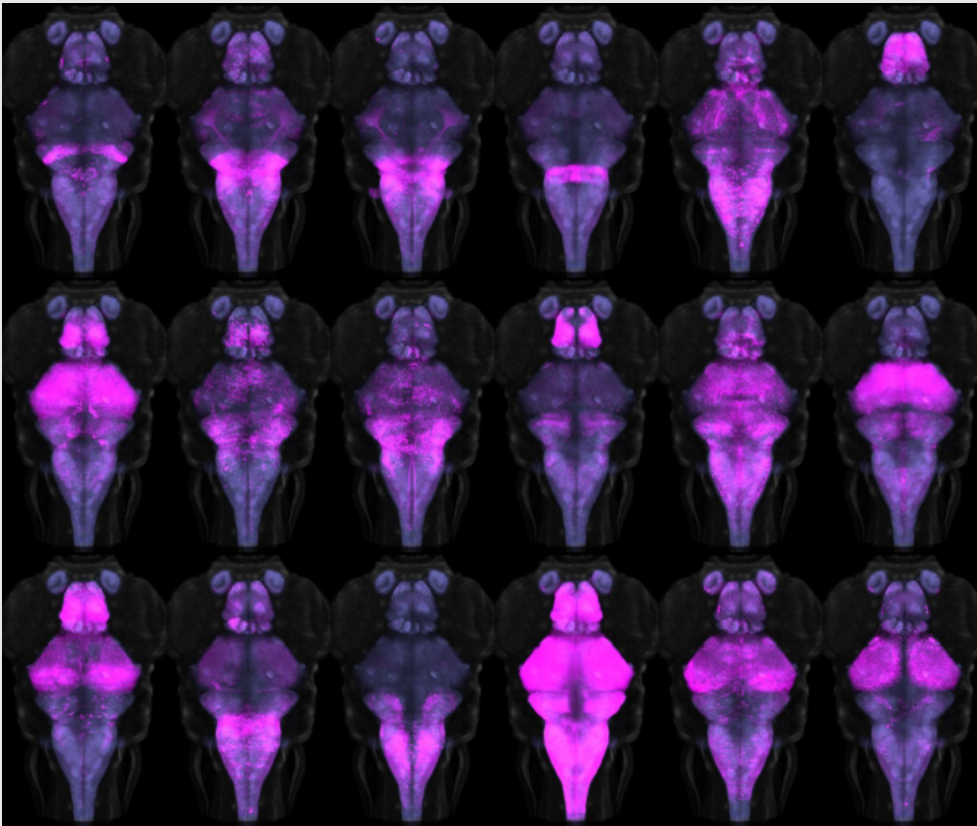

**FIGURE 1. Cre transgenic lines for intersectional genetic targeting**

Montage of 18 transgenic and enhancer trap lines that express Cre in discrete subsets of neurons. A UAS:Switch transgenic line ensures that only neurons expressing both Gal4 and Cre are labeled by a reporter gene.

responses are initiated by giant reticulo-spinal neurons in the medulla, which receive short-latency sensory input from diverse sensory modalities. Although highly stereotyped, startle responses are nevertheless modulated by sensory context and behavioral state and are therefore an excellent system in which to understand how such information is integrated with behavioral selection.

In mammals, including humans, the startle response to a strong auditory stimulus can be inhibited by pre-exposure to a weak acoustic 'prepulse.' This form of startle modulation, termed prepulse inhibition, is diminished in several neurological conditions, including schizophrenia. The precise pattern of neuronal connections that enable prepulse inhibition is not known, yet understanding the mechanism of prepulse inhibition would permit rational investigation into the mechanism by which schizophrenia risk factors influence neuronal circuitry. Vibrational stimuli trigger rapid-escape swims in zebrafish, which are mediated by giant reticulo-spinal neurons, in a manner similar to the central neurons controlling startle responses in mammals. Escape swims are suppressed by pre-exposure to a prepulse, allowing us to apply the powerful suite of genetic tools available in zebrafish to identify neurons that mediate prepulse inhibition.

To identify a transgenic zebrafish line that genetically labels neurons required for prepulse inhibition, we conducted a circuit-breaking screen. In this screen, we first generated a library of neuron-specific Gal4-enhancer trap lines marking distinct populations of neurons in the brain; we then ablated the neurons in each enhancer trap line before testing for prepulse inhibition. We identified a transgenic line, *y252*, that

labeled a discrete population of neurons in the hindbrain whose ablation or opto-genetic inhibition led to dysregulation of prepulse inhibition. We discovered that the neurons genetically labeled in *y252* are specified by the gene *Gsx1*, a transcription factor previously implicated in differentiation of both excitatory and inhibitory interneurons in the spinal cord. *Gsx1* was expressed in the mouse brainstem in the proliferative zone, which gives rise to regions previously implicated in prepulse inhibition. We obtained *Gsx1* knockout mice and performed behavioral testing. Knockout mice showed normal startle sensitivity but a strong reduction in prepulse inhibition. The results thus show that *Gsx1* expression defines neurons that are required for prepulse inhibition across vertebrate species. Given that prepulse inhibition is abnormal in neuropsychiatric disorders with developmental origins, including schizophrenia and autism, our work will help identify and probe fundamental defects in circuitry that is abnormal in these conditions (Reference 1).

A major outstanding question remains the specific identity of the *Gsx1* neurons responsible for prepulse inhibition, given that these neurons are located in several regions of the brain. To tackle this question, we developed new methods for monitoring and manipulating subgroups of *Gsx1* neurons. First, we use volumetric calcium imaging to simultaneously visualize the activity in thousands of *Gsx1* neurons during a prepulse inhibition paradigm. At the same time, we record tail movement responses to startle stimuli, with and without prepulse exposure. This is enabling us to locate specific *Gsx1* neurons whose activity correlates strongly with behavioral prepulse inhibition. To demonstrate that such neurons are causally related to prepulse inhibition, we established an intersectional genetic method to ablate subgroups of *Gsx1* neurons, by developing a library of Cre lines (Figure 1) and a UAS vector that requires both Gal4 and Cre expression in the same cell for reporter expression (UAS:KillSwitch).

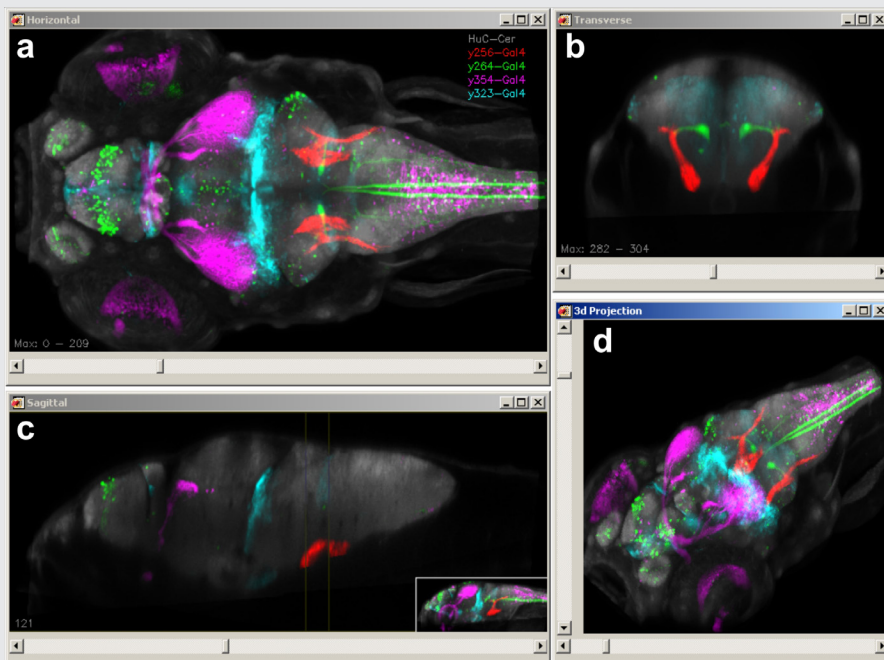

**FIGURE 2. A transgene expression atlas for zebrafish**

We imaged more than 100 transgenic lines at high resolution and computationally registered images to a common reference brain, so that expression patterns could be overlaid. New Brain Browser software allows transgenic lines that label selected brain regions to be quickly identified and permits prediction of transgenic lines that co-express in the same cell populations. Users browse the atlas by simultaneously viewing horizontal (a), transverse (b) and sagittal (c) views of brain sections or projections (a–b), which display expression data for co-registered transgenic lines. In addition, a 3D projection view helps reveal the spatial relationships of brain regions and expression patterns (d).

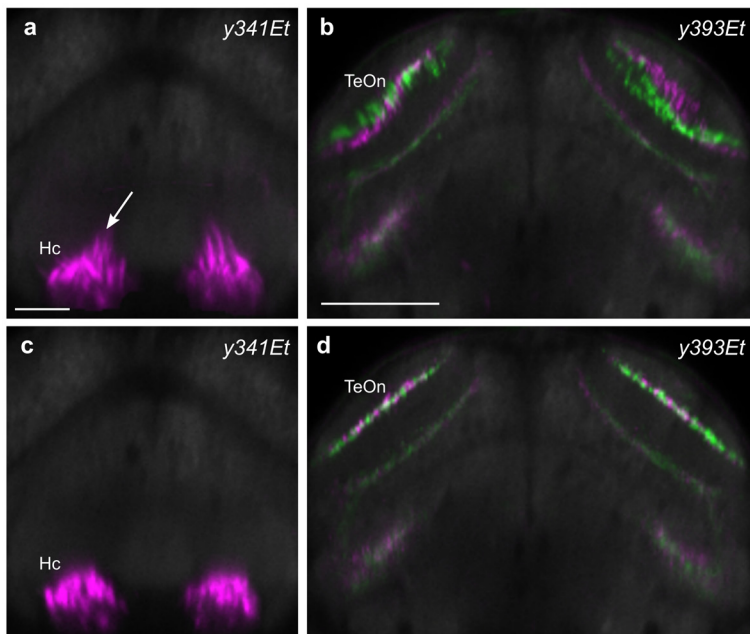

**FIGURE 3. Improved brain registration for larval zebrafish**

We compared several algorithms for deformable image registration to optimize brain alignment in larval zebrafish. Our previous studies employed elastic registration using a b-spline-based transformation, which resulted in distortion of cell morphology in several brain regions, such as the caudal hypothalamus (a), and imprecise registration in other parts of the brain, including the tectal neuropil (b). In contrast, symmetrical diffeomorphic transformation using ANTs better preserved cell morphology (c) and increased the precision of registration in areas such as the tectal neuropil (d).

Pharmacological experiments in mammals suggest that prepulse inhibition is likely to be mediated by several mechanisms with overlapping temporal profiles. Our genetic experiments support this idea. Inactivation of *Gsx1* neurons in zebrafish leads only to a deficit in prepulse inhibition at inter-stimulus intervals between prepulse and startle stimulus of greater than 100 ms, indicating that a separate group of neurons instantiate prepulse inhibition at short inter-stimulus intervals. We therefore established a new circuit-breaking screen to locate these neurons.

## Tools for analyzing neuronal circuits that control behavior

We previously described a new method for restricting transgene expression to the nervous system, by incorporating a neuronal-restrictive silencing element. Using this method, we constructed a library of 240 Gal4 enhancer-trap transgenic fish with unique and restricted patterns of neuronal expression. By performing high-resolution brain imaging on more than 300 larvae—including 80 of these lines and 29 other transgenic lines—and applying software developed for human brain imaging, we aligned the brain scans to a common reference, so that the expression in any of these lines can be compared at cellular-level resolution (Figure 2). This database, with associated *Brain Browser* software, formed the basis for a new atlas of the larval brain, a powerful resource for neurobiological studies (Reference 3).

A unique feature of brain imaging in zebrafish is the possibility of visualizing the overall architecture of the brain, while simultaneously recording the position and morphology of constituent labeled neurons. Thus, a particular challenge for deformable brain registration in larval zebrafish is to achieve highly precise global registration, without severely distorting the shape of individual cells. In the first release of our Brain Browser, we used an elastic brain registration algorithm that co-aligned brains with a precision of about 1 cell diameter but also produced salient abnormalities in cell morphology in several brain regions. More recently, we calibrated parameters for the symmetric diffeomorphic normalization algorithm in ANTs

(Advanced Normalization Tools) and found that it was possible to achieve similar, or better precision, without sacrificing cell morphology (Figure 3). In fact, multi-channel registration with ANTs allowed us to integrate our database of transgene expression patterns with an independent zebrafish brain atlas, Z-Brain, that contains additional gene expression patterns and neuroanatomical annotations (Reference 4).

The more than 100 lines included in the *Brain Browser* database together provide a way to transgenically target at least 70% of neurons in the larval brain. Most of these lines express Gal4 allowing activation of reporters downstream of a UAS (upstream activating sequence) element. We therefore also worked to improve existing UAS reporters for ablating and activating neurons. Specifically, we developed new reagents and protocols that allow for highly efficient neuronal ablation or for sensitizing neurons to excitatory input in the context of their normal neuronal functions (Reference 5). Together, these genetic tools allow us to target highly specific neurons within the larval brain for visualizing activity or altering function, helping us and others decode their role within neuronal circuits.

## Additional Funding

- US Israel Binational Fund 2013433 (2014): Ongoing, with Yoav Gothilf, Tel Aviv University

## Publications

1. Bergeron SA, Carrier N, Li GH, Ahn S, Burgess HA. Gsx1 expression defines neurons required for prepulse inhibition. *Mol Psychiatry* 2015 20:974-985.
2. Horstick EJ, Mueller T, Burgess HA. Motivated state control in larval zebrafish: behavioral paradigms and anatomical substrates. *J Neurogenet* 2016 30:122-132.
3. Marquart GD, Tabor KM, Brown M, Strykowski JL, Varshney GK, LaFave MC, Mueller T, Burgess SM, Higashijima I, Burgess HA. A 3D searchable database of transgenic zebrafish Gal4 and Cre lines for functional neuroanatomy studies. *Front Neural Circuits* 2015 9:78.
4. Marquart GD, Tabor KM, Horstick EJ, Brown M, Burgess HA. High precision registration between zebrafish brain atlases using symmetric diffeomorphic normalization. *bioRxiv* 2016 081000:1-26.
5. Horstick EJ, Tabor KM, Jordan DC, Burgess HA. Genetic silencing and selective activation using nitroreductase and TTX insensitive channels. *Methods Mol Biol: Zebrafish* 2016 1451:355-361.

## Collaborators

- Kevin Briggman, PhD, *Circuit Dynamics and Connectivity Unit, NINDS, Bethesda, MD*
- Yoav Gothilf, PhD, *Tel-Aviv University, Tel-Aviv, Israel*
- Shin-ichi Higashijima, PhD, *National Institutes of Natural Sciences, Aichi, Japan*
- Thomas Mueller, PhD, *Kansas State University, Manhattan, KS*
- Ralph Nelson, PhD, *Basic Neurosciences Program, NINDS, Rockville, MD*
- Forbes Porter, MD, PhD, *Section on Molecular Dysmorphology, NICHD, Bethesda, MD*

## Contact

For more information, email [haroldburgess@mail.nih.gov](mailto:haroldburgess@mail.nih.gov) or visit <http://ubn.nichd.nih.gov>.



## Global Regulation of Gene Expression by ppGpp

Our research is aimed at a fundamental molecular understanding of the regulatory connections between stress and bacterial growth (in *E. coli*, for example) that are mediated by two signal nucleotide analogs, pppGpp and ppGpp, abbreviated as (p)ppGpp. The analogs differ from GTP and GDP simply by the presence of a pyrophosphate esterified on the 3'-ribose hydroxyl of GTP or GDP. When these analogs were discovered nearly 50 years ago, they represented a new structural family of nucleotide second messengers, the first being the cyclic purines c-AMP and c-GMP. Additional cyclic dinucleotides (c-diGMP, c-diAMP, and c-GAMP) are found in prokaryotes and eukaryotes. Together, these comprise extensive nucleotide-centric regulatory networks that function to sense damaged DNA or RNA, leading to protecting hosts from foreign invasions of nucleic acids (Burroughs AM *et al. Nucleic Acids Res* 2015;43:1063; Burroughs AM, Aravind L. *Nucleic Acids Res* 2016;44:8525). In contrast, (p)ppGpp seems to have arisen to address more primordial functions, namely protecting bacterial cells from nutritional and physical sources of stress that impair growth.

The importance of ubiquitous (p)ppGpp in bacteria is that accumulation of these compounds is triggered by exquisitely sensitive sensing of even minor disturbances in fundamental metabolism of amino acids, carbohydrates, or lipids. The ensuing response is often called the stringent response, which operates incrementally over about a 100-fold range of elevated (p)ppGpp concentrations, to reach a maximum equivalence with GTP levels. As a first approximation, the full-blown stringent response dramatically slows bacterial growth and renders cells semi-dormant. One common physiological effect is to limit synthesis of the translational apparatus. The benefit of this adjustment can be thought of as conserving resources not needed when growth slows or stops. The change is accompanied by coordinating many other stress-specific adjustments of global gene expression to form elements that minimize damage and ultimately adapt to overcome the stress.

The fundamental understanding of (p)ppGpp regulation has emerged to be important for clinical microbiology. Almost all bacterial pathogens survive in cellular hosts because they can overcome the stress conditions occasioned by intracellular host defenses. The

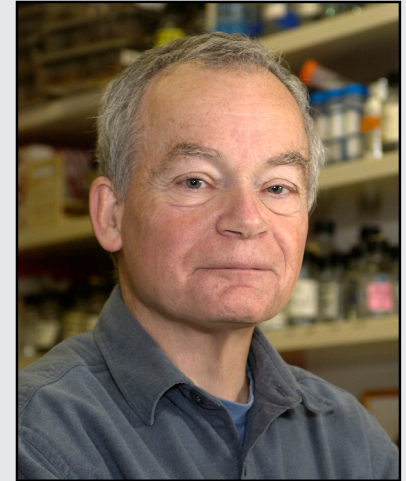

**Michael Cashel, MD, PhD, Head,**  
*Section on Molecular Regulation*  
Llorenc Fernandez-Coll, PhD,  
*Postdoctoral Intramural*  
*Research Training Award Fellow*  
Suanam Vij, AB, *Postbaccalaureate*  
*Intramural Research Training*  
*Award Fellow*

stringent response is triggered by many such stresses. Together with the apparent absence of (p)ppGpp in animal cells, this has given rise to efforts to screen for novel chemical agents that eliminate (p)ppGpp, thereby immobilizing bacterial adaptation to stress and compromising pathogenicity. Anti-biofilm D-amino acid-containing peptides with amphipathic helices can block (p)ppGpp accumulation (Pletzer D *et al. Curr Opin Microbiol* 2016;33:35). Some of these peptides have emerged as effective therapy for model subcutaneous abscesses caused by methicillin-resistant (MRSA) *Staphylococcus aureus* (de la Fuente-Núñez C *et al. PLoS Pathog* 2014;10:e1004152). More generally, pharmacological targets of almost all antibiotics are typically inhibitors of essential metabolic pathways that are robust in growing cells. Given that (p)ppGpp occasions a semi-dormant state, as a first approximation, this is taken to explain how very rare instances of random cells with spontaneous high (p)ppGpp in a growing population of sensitive cells become antibiotic tolerant (Hauryliuk V *et al. Nat Rev Microbiol* 2015;13:298), leading to the persistence of the tolerant pathogens during antibiotic treatment, which resume growth and host damage when the antibiotic is removed. The phenomenon of pathogen persistence is probably related to carrier states of pathogens that persist even in the absence of antibiotics, although the mechanism is less clear. For example, in *M. tuberculosis*, the frequencies of the carrier state in animal models can be shown to be reduced in the absence of (p)ppGpp (Primm TP *et al. J Bacteriol* 2000;182:4889). Our research last year involved pGpp and (p)ppApp, described in earlier reports as a potentially new member of the noncyclic (p)ppGpp family. Progress on the (p)ppApp work has come through collaboration with a former lab member, Katarzyna Potrykus. This year, we collaborated in uncovering a facilitating role for ppGpp in the process of transcription-coupled repair of DNA damage.

## (p)ppApp

Initial studies that led to a focus on (p)ppApp were presented in earlier reports. The studies were prompted by the existence of small single-domain hydrolases, called MESH (Metazoan E. coli Spot Homologs), shown by another laboratory. The enzymes are single-domain hydrolases with structural homology to known (p)ppGpp hydrolase domains present in bifunctional synthetases. As mentioned, all (p)ppGpp hydrolases remove a pyrophosphate residue and also are dependent on  $Mn^{++}$ . A pivotal discovery made by Katarzyna Potrykus was that the MESH hydrolases display a degenerate substrate specificity in that they cleave (p)ppApp as well as (p)ppGpp. A concerted effort of ours, reported earlier, was to exploit the known crystal structures of MESH hydrolases with (p)ppGpp-specific hydrolase in order to derive a protein that could hydrolyze (p)ppApp but not (p)ppGpp. This was not, however, successful. Potrykus identified bacterial genomes that encoded MESH homologs. Several of these proteins were purified and, indeed, one was found that actively hydrolyzes (p)ppApp but not (p)ppGpp. The characterization of the enzymes used new NAD(P)-coupled spectrophotometric assays to measure hydrolysis rates of the nucleotides. The assays were devised here and developed further by Nathan Thomas, a postbaccalaureate fellow, whose work won a first prize NICHD poster award last year. The existence of the (p)ppApp-specific enzyme now permits one to screen for the cellular targets of the hydrolase. Such targets should validate (p)ppApp as an addition to the (p)ppGpp family of nucleotides. Many potential targets exist, given that they include any adenylate derivative with a free 3'-ribose hydroxyl; examples include Coenzyme A, FAD, and NAD, all known to be synthesized *in vitro* by a pyrophosphoryl transferase from a species of *Streptomyces*.

## ppGpp facilitates transcription-dependent DNA repair.

Earlier reports from other labs suggested that maintenance of genomic integrity falls within the realm of (p)ppGpp-centric regulation. We collaborated in a study that further defined one aspect of these effects.

The first clue was finding that high cellular basal levels of ppGpp conferred resistance to UV damage or to genotoxic bulky DNA adducts, when compared with ppGpp-deficient (ppGpp<sup>0</sup>) cells. Similar exposures of wild-type cells with low basal levels resulted in a transient ppGpp accumulation with levels increased far above basal values by 15 min, which thereafter decayed with a half-life of about 10 min. Evidence that repair of the DNA damage is directly linked to transcription came from the observation that repair of thymine dimers formed by UV irradiation occurred predominantly on the transcribed strand. The Mfd protein is known to participate in transcription-coupled repair through binding to the leading surface of RNA polymerase (RNAP). The binding event is thought to position the stalled enzyme near bulky DNA lesion, which allows recruitment of the proteins that initiate nucleotide excision repair. Subsequent binding of the UvrD helicase allows the RNAP to back up on the template to expose the DNA damaged region. The “backtracking” allows entry of additional nucleotide excision repair enzymes. Epistasis studies with ppGpp<sup>0</sup> mutants deleted also for either *mfd* or *uvrD* revealed additive effects of deleting *mfd* but not *uvrD*, which would suggest that ppGpp and UvrD affect the same mechanism, as if the backtracking function known for UvrD is likely to be the ppGpp contribution as well.

The transcription elongation factors GreA and GreB are even better known for their backtracking functions. When *greA* and *greB* are deleted, the otherwise sensitive ppGpp<sup>0</sup> cells become resistant to DNA damage. DksA is another transcription factor often required for (p)ppGpp regulation. We showed previously that deletion of both *greAB* and *dksA* are (synthetic) lethals. It is consistent that deleting *dksA* sensitizes wild-type cells to damage, while overexpressing DksA makes them more resistant. These many inferences could be verified at the level of *in vitro* transcription with purified components. Adding UvrD potentiated backtracking, visualized as enhanced pausing in single-round runoff transcripts. The effect was further enhanced by adding ppGpp with or without DksA but not by adding DksA alone. Others have reported a modest cleft opening of the DNA clamp of RNA polymerase (sometimes called a crab claw) when ppGpp is added. It is plausible that this effect of ppGpp might weaken the grip of polymerase on the DNA template and favor backtracking. Such a mechanism could explain how ppGpp might couple transcription to DNA repair. Again *in vitro* studies provide supportive evidence. RNAP can be assembled in elongation complexes at a fixed position then probed with exonuclease III digestion to observe that the presence of ppGpp shifts the position backward. Consistent changes could also be found *in vivo* footprints with or without ppGpp as well as by deleting or overexpressing *uvrD*. Finally, effects of ppGpp could be shown to be mimicked by an RNA polymerase mutant (RpoB\*35, H1244Q), previously found to phenocopy several regulatory effects of ppGpp. The proposed model for ppGpp facilitation of transcription-coupled repair involves transient ppGpp accumulation, which may be of advantage to avoid possible complications of more permanent effects, such as excessive slippage or collisions with replication forks. Exactly how DNA damage provokes ppGpp accumulation and why it is transient remains a puzzle. Future approaches might be to measure the effect of *relA* or *spoT* mutants on ppGpp accumulation during exposures to DNA-damaging agents. These genes are known to mediate specific sensing systems that provoke ppGpp.

## Publications

1. Gaca AO, Kudrin P, Colomer-Winter C, Beljantseva J, Liu K, Anderson B, Wang JD, Rejman D, Potrykus K, Cashel M, Hauryliuk V, Lemos JA. From (p)ppGpp to (pp)pGpp: characterization of regulatory effects of pGpp synthesized by the small alarmone synthetase of *Enterococcus faecalis*. *J Bacteriol* 2015 197(18):2908-2919.

2. Kamarthapu V, Epshtein V, Benjamin B, Proshkin S, Mironov A, Cashel M, Nudler E. ppGpp couples transcription to DNA repair in *E. coli*. *Science* 2016 352:993-936.
3. Potrykus K, Cashel M. Preferential cellular accumulation of ppGpp or pppGpp in *Escherichia coli*. In: *de Bruijn FJ, ed. Stress and Environmental Regulation of Gene Expression and Adaptation in Bacteria. John Wiley and Sons, Inc.* 2016 7:1-8.

## Collaborators

- Katarzyna Potrykus, PhD, *University of Gdansk, Gdansk, Poland*
- Evgeny Nudler, PhD, *New York University School of Medicine, New York, NY*
- Agnieszka Szalewska-Palasz, PhD, *University of Gdansk, Gdansk, Poland*

## Contact

For more information, email [cashel@mail.nih.gov](mailto:cashel@mail.nih.gov) or visit <http://smr.nichd.nih.gov>.

## Variability Between the Degrees of Maturation in Individual Dengue Virions

Disparate membrane remodeling reactions are tightly controlled by protein machinery but are also dependent on the lipid composition of the membranes. Whereas each kind of protein has its own individual personality, membrane lipid bilayers have rather general properties manifested by their resistance to disruption and bending. Our long-term goal is to understand how proteins break and reseal membrane lipid bilayers in important cell biology processes, such as membrane fusion and crossing cell membranes by water-soluble drugs on their way to intracellular targets. We expect that the analysis of the molecular mechanisms of different membrane rearrangements will clarify the generality of emerging mechanistic insights. Better understanding of these mechanisms will bring about new ways of controlling them and lead to new strategies for quelling diseases involving cell invasion by enveloped viruses, intracellular trafficking, and intercellular fusion.

In addition to our on-going work on poorly understood examples of cell-to-cell fusion processes, such as fusion stages of formation of multinucleated myotubes and osteoclasts, where even identities of the proteins involved remain to be clarified, in a recent study we focused on one of the best characterized fusion machineries, dengue virus envelope (E) protein. The important human pathogen dengue virus is a mosquito-borne single positive-stranded RNA virus, which enters cells via fusion between viral envelope and endosomal membrane. The protein network at the surface of the dengue viral particle is formed by the E protein and either membrane (M) protein in mature virus or prM, the uncleaved precursor of M in the immature virus. We examined the variability between the degrees of maturation in different virions within the same population.

### The human pathogen dengue virus and its maturation

Dengue virus (DENV) causes the most prevalent mosquito-borne viral disease, with an estimated 3.6 billion people living in risk areas. Control of the growing threat of DENV is hindered by the lack of effective therapies and vaccines. Newly assembled DENV particles undergo maturation to become infectious. The proteins present on the surface of the dengue immature virus are the envelope (E)



**Leonid V. Chernomordik, PhD,**  
*Head, Section on Membrane  
Biology*

Eugenia Leikina, DVM, *Senior  
Research Assistant*

Kamram Melikov, PhD, *Staff  
Scientist*

Elena Zaitseva, PhD, *Staff Scientist*

Santosh K. Verma, PhD, *Visiting  
Fellow*

Berna Uygur, PhD, *Postdoctoral  
Intramural Research Training  
Award Fellow*

Harold Shin, BS, *Postbaccalaureate  
Fellow*

protein, which is responsible for viral entry, and prM, which consists of an N-terminal pr domain followed, via a furin cleavage site, by the M protein. Interactions between the pr portion of prM and E-protein prevent premature viral fusion or inactivation in the acidic intracellular compartments through which virions traffic. The mature DENV envelope contains E protein and M protein, a cleaved derivative of prM. The maturation is required for formation of pre-fusion conformation of E-protein. Following E-protein binding to cell surface receptors, the virus is internalized by endocytosis.

In earlier studies, we dissected the pathway of DENV entry and fusion and identified an anionic lipid specific for late endosomes as an essential lipid cofactor of E-protein fusion machinery. Our findings explained why DENV fuses not in early but in late endosomes, where a combination of acidic pH and anionic lipids facilitates fusogenic restructuring of E from homodimer to homotrimer, which brings about fusion between viral envelope and endosomal membrane and thus effectively delivers viral RNA into cytosol in the vicinity of the translation-replication sites. Our work also explained why earlier attempts by different laboratories to develop fusion assays for DV fusion failed. We proceeded to develop an arsenal of high-throughput assays for DENV cell-surface binding, internalization, and intracellular fusion.

In our most recent study, in collaboration with Leonid Margolis's lab, we focused on the surface protein composition of DENV particles and developed an assay to characterize the maturation status of individual virions. We examined whether there are any DENV particles that are fully matured, i.e., in which all prM molecules are cleaved, or all the virions are either fully immature with all prM molecules in uncleaved form or "mosaic", with the same virions carrying both M protein and prM. To answer this question, we analyzed these proteins on the surface of single virions using a novel high-throughput flow-virometry technique to characterize the degree of maturation of individual virions in a preparation of infectious DENV. We labeled DENV with a fluorescent lipid probe and then with fluorescent antibody to prM protein, and captured labeled virions (operationally defined as a membrane particle that carries E protein) with small MNPs coupled with an antibody against E protein. We then separated the DENV-MNPs complexes from unbound antibodies using magnetic columns and eluted DENV-MNPs complexes from the columns. Finally, we analyzed the eluted complexes with a flow cytometer. We found that, in the DENV population produced by BHK-21 cells, approximately half the virions are fully mature as no prM could be detected on their surface. In contrast, furin-deficient LoVo cells produced a DENV population in which only about 15% are mature virions. Detailed characterization of the maturation status of DENV released by infected cells is especially important given that immature DENV has been found to play a significant role in disease pathogenesis. It is worth noting that our approach characterizes the variability between virions within the same population and thus complements the existing bulk techniques, which describe the composition and properties of an average virion in the preparation. Given that the heterogeneity of viral particles may impact their biological properties, we expect that the high throughput approach we developed will help produce a vaccine and antivirals against DENV and possibly against other viruses.

## *Additional Funding*

- United States - Israel Binational Science Foundation (BSF) grant "Machinery of myoblast fusion" 2015-2019
- NICHD FY16 NICHD Intramural DIR/DIPHR HIV/AIDS Research Award, 2016, 2017

## Publications

1. Kozlov MM, Chernomordik LV. Membrane tension and membrane fusion. *Curr Opin Struct Biol* 2015 33:61-67.
2. Chernomordik LV, Kozlov MM. Myoblast fusion: playing hard to get. *Dev Cell* 2015 32:529-530.
3. Zicari S, Arakelyan A, Fitzgerald W, Zaitseva E, Chernomordik LV, Margolis L, Grivel J-Ch. Evaluation of the maturation of individual dengue virions with flow virometry. *Virology* 2016 488:20-27.
4. Leikina E, Defour A, Melikov K, Van der Meulen JH, Nagaraju K, Bhuvanendran S, Gebert C, Pfeifer K, Chernomordik LV, Jaiswal JK. Annexin A1 deficiency does not affect myofiber repair but delays regeneration of injured muscles. *Sci Rep* 2015 5:18246.

## Collaborators

- Anush Arakelyan, PhD, *Section on Intercellular Interactions, NICHD, Bethesda, MD*
- Aurelia Defour, PhD, *Children's National Medical Center, Washington, DC*
- Claudia M. Gebert, PhD, *Section on Genome Imprinting, NICHD, Bethesda, MD*
- Jyoti Jaiswal, PhD, *George Washington University School of Medicine and Health Sciences, Washington, DC*
- Michael M. Kozlov, PhD, *Dhakil, Sackler Faculty of Medicine, Tel Aviv University, Tel Aviv, Israel*
- Leonid Margolis, PhD, *Section on Intercellular Interactions, NICHD, Bethesda, MD*
- Karl Pfeifer, PhD, *Section on Genomic Imprinting, NICHD, Bethesda, MD*
- Benjamin Podbilewicz, PhD, *Technion-Israel Institute of Technology, Haifa, Israel*
- Sonia Zicari, PhD, *Section on Intercellular Interactions, NICHD, Bethesda, MD*

## Contact

For more information, email [chernoml@mail.nih.gov](mailto:chernoml@mail.nih.gov) or visit <https://irp.nih.gov/pi/leonid-chernomordik>.

## Building the Zebrafish Lateral Line System

Our current studies examine how the posterior lateral line system is built in the zebrafish nervous system. Our goal is to define the genetic regulatory network that coordinates cell fate and morphogenesis in the lateral line system and to build computational models that help us understand how this relatively simple and extremely accessible sensory system in zebrafish builds itself.

The lateral line is a mechanosensory system that detects water flow and consists of sensory organs called neuromasts, which are distributed in a stereotypic pattern over the surface of the zebrafish. Each neuromast has sensory hair cells at its center, which are surrounded by support cells that serve as progenitors for the production of more hair cells during growth and regeneration of neuromasts. The development of this superficial sensory system in zebrafish can be easily observed in live embryos with transgenic lines expressing fluorescent proteins in specific subsets of cells of the lateral line system. In addition, a range of genetic and cellular manipulations can be used to investigate gene function.

The function of sensory hair cells in fish neuromasts is remarkably similar to that of hair cells in the vertebrate ear. Furthermore, the gene-regulatory network that determines specification of neuromast hair cells is very similar to the one specifying hair-cell fate in the human ear. Like the hair cells in our ears, neuromast hair cells can be damaged by exposure to drugs such as aminoglycosides, to copper ions, and to noise. However, unlike our ears, in which the loss of hair cells can be permanent, neuromast hair cells have a remarkable ability to regenerate. Hence, the lateral line system serves as an excellent model system for understanding development and for developing strategies to engineer regeneration of sensory hair cells.

The posterior lateral line system is initially established by the posterior lateral line (pLL) primordium, a cluster of about a 100 cells that migrate from the ear to the tip of the tail, periodically depositing neuromasts. Recent studies showed that the mechanisms that determine and guide collective migration and deposition of cells from the pLL primordium are remarkably similar to those that determine the collective migration of metastatic cancer cells. Hence, the lateral line system has also recently emerged as an excellent



**Ajay Chitnis, MBBS, PhD, Head,**  
*Section on Neural Developmental Dynamics*

Damian E. Dalle Nogare, PhD,  
*Staff Scientist*

Gregory Palardy, BS, *Research Technician*

Chongmin Wang, MS, *Research Technician*

Harsha Mahabaleshwar, PhD,  
*Postdoctoral Fellow*

Uma Neelathi, PhD, *Postdoctoral Fellow*

Caitlin Fox, BS, *Graduate Student*

Alexandria Bikker, BS,  
*Postbaccalaureate Intramural Research Training Award Fellow*

Marci Rosenberg, BS,  
*Postbaccalaureate Intramural Research Training Award Fellow*



system for studying the biology of metastatic cancer cells.

Our expectation is that understanding the genetic regulatory network that coordinates cell fate in and morphogenesis of the zebrafish lateral line system will ultimately have a profound impact on translational studies that address a wide range of issues, including the development and regeneration of sensory systems and therapies directed at limiting the spread of cancer through metastasis.

## Self-organization of the zebrafish lateral line primordium

Interactions between the Wnt, FGF (fibroblast growth factor), Notch, BMP (bone morphogenetic protein), and chemokine signaling pathways in the pLL primordium provide a framework for understanding how cell fate and morphogenesis are coordinated in this group of about a hundred cells, as they collectively migrate under the skin from the ear to the tip of the tail. We combined an experimental approach with computational modeling to define the mechanisms that determine both the periodic formation of neuromasts and their deposition along with inter-neuromast cells, as the pLL primordium migrates along a path defined by chemokine expression.

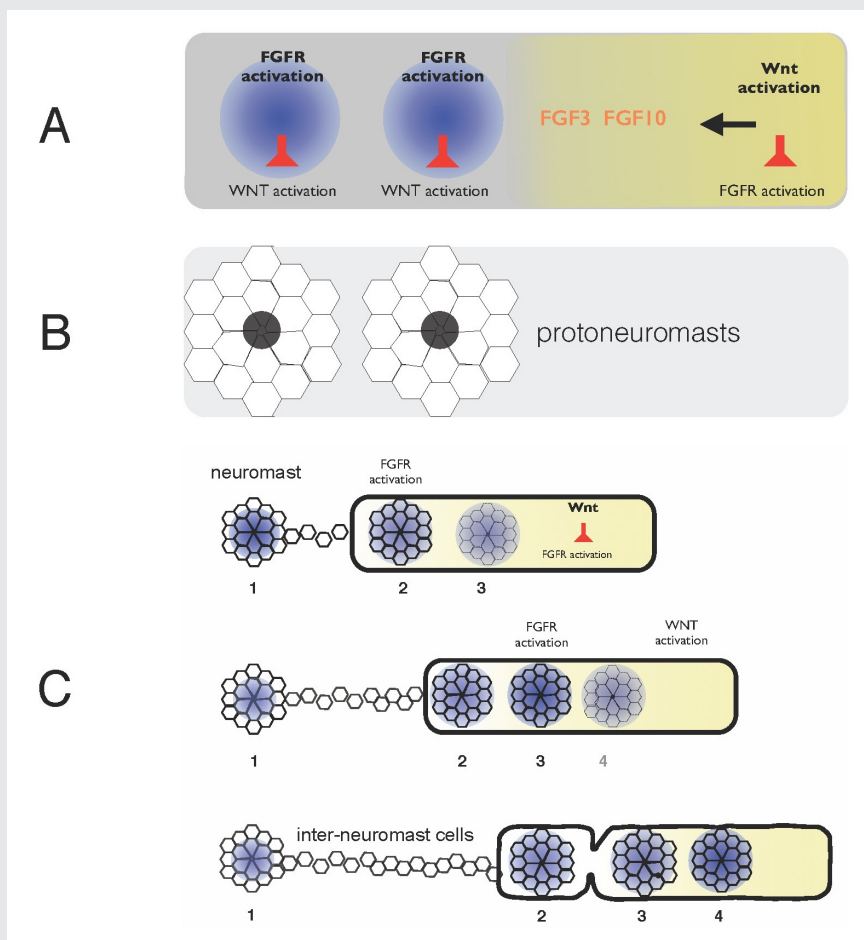

**FIGURE 1. Self-organization of zebrafish lateral line primordium**

A) FGFs secreted in response to Wnt activity in a leading zone (*yellow*) activate FGFRs in the trailing zone (*blue*). Wnt activity inhibits FGFR activation, and FGFR activation induces expression of a secreted factor that inhibits Wnt activity. B) Activation of FGFRs coordinates formation of protoneuromasts, in which cells reorganize to form epithelial rosettes, and a central cell (*black*) is specified as a sensory hair-cell precursor. C) Once about two neuromasts form, the primordium starts migrating. The Wnt zone (*yellow*) progressively shrinks as new protoneuromasts form progressively closer to the leading end. As the Wnt system shrinks, so does the primordium, and neuromasts and interneuromast cells are shed from the trailing end.

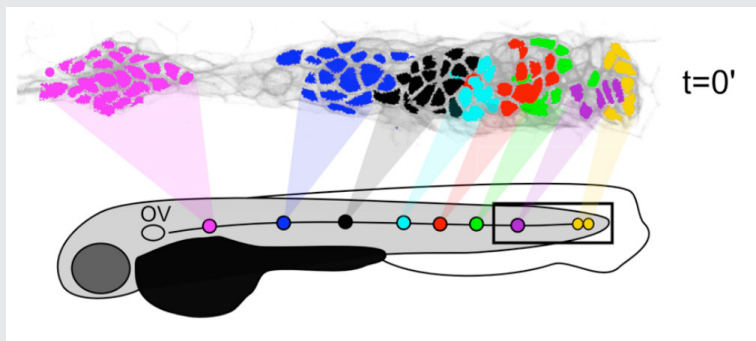

**FIGURE 2.** Neuromasts are formed by the local proliferation of cells along the length of the primordium.

Filled circles represent sequentially deposited neuromasts. Corresponding colors of cells in the PLLp at time  $t=0'$  show which populations underwent local expansion to give rise to each of these neuromasts.

Wnt proteins initially activate Wnt-beta catenin in a broad leading zone of the primordium. Cells with Wnt activity respond by becoming a source of FGF ligands. At the same time, they express factors that prevent a response to these FGFs. As leading cells with relatively high levels of Wnt activity are prevented from responding to the FGFs, an FGF-responsive center is initially established at the trailing end of the pLL primordium, where Wnt activity is weakest. The activation of FGF receptors in these trailing cells coordinates the formation of nascent neuromasts, where cells reorganize to form epithelial rosettes, and a central cell is specified as a sensory hair-cell progenitor. However, the FGF-responsive center also becomes the source of a secreted Wnt antagonist, which progressively restricts the domain of active Wnt activity to the smaller leading zone. The shrinking Wnt system allows the formation of another FGF signaling-dependent 'protoneuromast' in its wake. In this manner, as the Wnt system shrinks, new protoneuromasts are formed, progressively closer to its leading end. After about the first two protoneuromasts form, the primordium starts migrating toward the tail.

As the pLL primordium migrates, cells are deposited from its trailing end, and the pLL primordium progressively shrinks. Cells that were incorporated into protoneuromasts are deposited as neuromasts, while cells that were not effectively incorporated into epithelial rosettes are deposited as interneuromast cells. Interestingly, shrinkage of the pLL primordium correlates with shrinking of the Wnt system, and the length of the Wnt active zone is always roughly 60% of the length of the primordium. While the reason for this correlation is still unclear, knowing the initial size of the Wnt system, and the rate at which it shrinks, provides a way to predict the permitted length of the primordium at any point during the course of migration. Trailing cells in a position that exceeds the permitted length of the primordium slow down, stop migrating, and are shed from the trailing end. The rate at which cells leave the migrating primordium depends on the rate at which the Wnt system shrinks and on the cell proliferation rate, as addition of cells adds to the length of the primordium, and hence to the possibility that trailing cells will fall outside the permitted length of the migrating primordium.

While the framework described above provides a broad description of the early self-organization of the PLLp system, many questions remain. In recent years we have focused on the following questions: (1) What is the precise lineage of cells in the migrating primordium and how do cells in different locations contribute to the sequential formation of neuromasts and to specific fates within deposited neuromasts? (2) What are mechanisms that determine the dynamics of Wnt-FGF signaling in the pLL primordium, including those that

determine its initial polarization, progressive shrinking of the leading Wnt system, and sequential formation of trailing FGF signaling centers in its wake? (3) Which signaling mechanisms determine collective migration of the pLL primordium and how are these signaling systems linked to the mechanics of migration? (4) What does the behavior of individual cells within the primordium reveal about the mechanisms of collective migration and cell-cell communication? (5) Can what has been learned from these studies allow us to build computational models and a theoretical framework that helps reconstruct how specific interactions between cells and their environment result in the coordination of morphogenesis, cell fate, and migration of the PLLp? Importantly, does failure of some of our models to recapitulate specific phenomena help identify gaps in our understanding and define questions for future examination?

## Characterizing cell migration, proliferation, lineage, and fate specification in the migrating PLLp at single-cell resolution

Many basic aspects of the biology of the PLLp, including proliferation patterns, lineage relationships, and the dynamics of neuromast deposition remain incompletely characterized. To unambiguously resolve such questions, we conducted time-lapse imaging of the PLLp, first at low resolution for some embryos, and then again for three independent embryos at a resolution that allowed us to track and catalog every single cell in the PLLp from early in migration until termination (approximately 24 hours). From this dataset, we constructed digital models of the PLLp. We could query these models to define the lineages of specific cells or subsets of cells, such as those that form specific neuromasts or that adopt specific fates within the neuromasts. Previous studies had suggested that the leading zone with Wnt activity maintains a proliferative population of progenitor cells that divide to produce a subset of daughter cells that move to a trailing zone, where, under the influence of FGF signaling, they differentiate to sequentially form neuromasts. However, our analysis revealed that proliferation in the PLLp is largely unpatterned and not especially high in the leading zone. Furthermore, protoneuromasts are not formed in the trailing zone from a self-renewing population of progenitors in a leading zone. Instead, they are formed by the local proliferation of cells along the length of the primordium in response to FGF signaling, as the Wnt signaling system, which locally inhibits protoneuromast formation, is progressively restricted to a smaller leading zone of the PLLp. The fate of deposited cells, within neuromasts, as central sensory hair cell progenitors, surrounding support cells, or as interneuromast cells between deposited neuromasts, is not determined by any obvious stereotyped lineages. Instead, their fate is determined, somewhat stochastically, as a function of a cell's distance from the center of a maturing protoneuromast. This observation is consistent with the notion that a cell's fate is determined in the PLLp by its level of exposure to active FGF signaling; the central cell in the protoneuromast, most likely specified earlier as a sensory hair cell progenitor by its exposure to the highest level of FGF signaling and via lateral inhibition mediated by Notch, becomes a source of FGF10. We suggest that proximity to this new central source of FGFs subsequently determines the level of FGF signaling and the eventual fate of surrounding cells in the maturing protoneuromast.

## A role for HSPGS in effective reception and delivery of FGF signals

Given that heparan sulfate proteoglycans (HSPGs) can influence both the range and efficacy of Wnt and FGF signaling, we examined the functions of several HSPG-related molecules that are expressed in a tissue-specific manner in the migrating pLL primordium. These included the HSPG Syndecan4 (Sdc4) and the 3-O-sulfotransferases HS3ST3B1a and HS3ST3B1b. Sdc4 has been described as a co-receptor for FGF, as Sdc4 can increase the affinity with which FGF associates with its primary receptor by forming a ternary complex with Sdc4. HS3ST3B1a and HS3ST3B1b are HSPG-modifying enzymes responsible for the last in a series of

modifications that result in addition of sulfate groups to specific positions on the HSPG sugar chain. It has been suggested that the sulfation step plays a specific role in increasing FGF10 receptor affinity.

We showed that *sdc4* is expressed at the highest level in the most trailing protoneuromasts and that its expression persists in deposited neuromasts. Both Wnt and FGF signaling systems inhibit its expression throughout most of the primordium, ensuring *sdc4* expression is only permitted in the most trailing protoneuromasts. Interference with *sdc4* function, using either morpholinos or CRISPR-generated mutants, reveals that Sdc4 is required for effective FGF signaling and that loss of its function is accompanied by delayed formation of protoneuromasts and slower primordium migration. Together, these observations suggest that *sdc4*, whose expression is restricted to the most trailing part of the PLLp, may be part of a feedback system that ensures optimum levels of FGF signaling at the trailing end, where access to FGFs secreted by leading cells is low.

HS3ST3B1a and HS3ST3B1b are both expressed at the leading end of the pLL primordium, where their expression is dependent on Wnt signaling. Disrupting the function of these sulfotransferases reduces expression of FGF signaling-dependent expression of *pea3* in the primordium, and there is a delay in maturation of nascent protoneuromasts. Together, the findings support a role for the sulfotransferases in determining effective FGF signaling. Given that the sulfotransferases are primarily expressed in a leading zone that is the source of FGF signals, we suggest that HS3ST3B1a and HS3ST3B1b likely play a critical role in determining effective delivery of FGF signals. How, remains a question for future studies.

## Publications

1. Matsuda M, Rand K, Palardy G, Shimizu N, Ikeda H, Dalle Nogare D, Itoh M, Chitnis AB. Epb4115 competes with Delta as a substrate for Mib1 to coordinate specification and differentiation of neurons. *Development* 2016 143(17):3085-3096.
2. Dalle Nogare D, Chitnis AB. Connecting physical cues and tissue patterning. *eLife* 2015 4:e11375.
3. Palardy G, Chitnis AB. Identification of the Mind bomb1 interaction domain in zebrafish DeltaD. *PLoS One* 2015 10(5):e0127864.

## Collaborators

- Hari Shroff, PhD, *Laboratory of Molecular Imaging and Nanomedicine, NIBIB, Bethesda, MD*

## Contact

For more information, email [chitnisa@mail.nih.gov](mailto:chitnisa@mail.nih.gov) or visit <https://irp.nih.gov/pi/ajay-chitnis>.

## Molecular Genetics of Heritable Human Disorders

We conduct research to delineate the pathophysiology of glycogen storage disease type I (GSD-I) and glucose-6-phosphatase-beta (G6Pase-beta or G6PC3) deficiency (GSD-Irs) and to develop novel therapies for these disorders. GSD-I consists of two subtypes, GSD-Ia, deficient in G6Pase-alpha (or G6PC), and GSD-Ib, deficient in the glucose-6-phosphate (G6P) transporter (G6PT or SLC37A4). A third disease, G6Pase-beta deficiency, also known as severe congenital neutropenia syndrome type 4, is not a glycogen storage disease but biochemically a GSD-I-related syndrome (GSD-Irs). G6Pase-alpha and G6Pase-beta are endoplasmic reticulum (ER)-bound G6P hydrolases, with active sites lying inside the lumen, which depend upon G6PT to translocate G6P from the cytoplasm into the ER lumen. The G6PT/G6Pase-alpha complex maintains interprandial glucose homeostasis, while the G6PT/G6Pase-beta complex maintains energy homeostasis and functionality of neutrophil and macrophages. GSD-Ia and GSD-Ib patients manifest a common metabolic phenotype of impaired glucose homeostasis not shared by GSD-Irs. GSD-Ib and GSD-Irs patients manifest a common myeloid phenotype of neutropenia and myeloid dysfunction not shared by GSD-Ia. Neutrophils express the G6PT/G6Pase-beta complex, and inactivation of G6PT or G6Pase-beta leads to the enhanced neutrophil apoptosis that underlies neutropenia in GSD-Ib and GSD-Irs. The G6PT/G6Pase-beta complex is also essential for energy homeostasis in neutrophils. A deficiency in either G6PT or G6Pase-beta prevents recycling of glucose from the ER to the cytoplasm, leading to neutrophil dysfunction. There is no cure for GSD-Ia, GSD-Ib, or GSD-Irs. Animal models of the three disorders are available and are being exploited to both delineate the diseases more precisely and to develop new treatment approaches, including gene therapy.

### Functional analysis of mutations in GSD-Irs

The enzyme G6Pase-beta is embedded in the ER membrane and catalyzes the hydrolysis of G6P to glucose and phosphate. To date, 33 distinct G6Pase-beta mutations have been identified in GSD-Irs patients, but only the p.R253H and p.G260R missense mutations have been characterized functionally for pathogenicity. We functionally characterized 16 of the 19 known missense mutations, using a sensitive assay based on a recombinant adenoviral vector-mediated

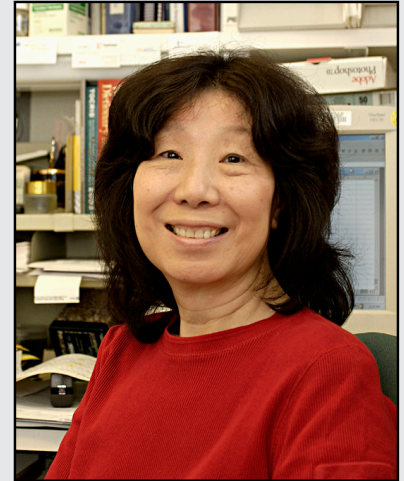

**Janice Y. Chou, PhD, Head, Section on Cellular Differentiation**

*Lisa Zhang, PhD, Staff Scientist*

*Chi-Jiunn Pan, BS, Senior Research Assistant*

*Jun Ho Cho, PhD, Visiting Fellow*

*Goo Young Kim, PhD, Visiting Fellow*

*Joon Hyun Kwon, PhD, Visiting Fellow*

*Javier Anduaga, BS, Technical Intramural Research Training Award Fellow*

*Kurt Berckmueller, BS, Predoctoral Intramural Research Training Award Fellow*

*Vamsi Reddy, BS, Predoctoral Intramural Research Training Award Fellow*

*Young Mok Lee, PhD, Guest Researcher*

*Brian C. Mansfield, PhD, Guest Researcher*

expression system to demonstrate pathogenicity. Twelve missense mutations completely abolish G6Pase-beta enzymatic activity, while the p.M116V, p.T118R, p.S139I, and p.R189Q mutations retain 1.1%, 1.3%, 49%, and 45%, respectively, of wild-type G6Pase-beta activity. A database of residual enzymatic activity retained by the G6Pase-beta mutations will serve as a reference for evaluating genotype-phenotype relationships.

## Mechanisms preventing hepatocellular adenoma/carcinoma in GSD-Ia mice receiving gene therapy

The hallmarks of GSD-Ia are impaired glucose homeostasis and long-term risk of hepatocellular adenoma/hepatocellular carcinoma (HCA/HCC). The predominant subtypes of HCA in GSD-Ia are inflammatory HCA (IHCA, 52%) and  $\beta$ -catenin-mutated HCA (bHCA, 28%). We previously showed that AAV (adeno-associated virus) mice that express more than five units of hepatic G6Pase- $\alpha$  activity maintain glucose homeostasis, demonstrate no HCA/HCC, and live under CR (caloric restriction). We recently showed that 75% of rAAV-treated mice expressing 1.5-4.9 units of hepatic G6Pase- $\alpha$  activity (AAV-low-NT mice) exhibit a similar phenotype. In view of the similarities between AAV-NT (NT, non-tumor) mice and animals living under CR, we examined pathways involved in CR for insights into mechanisms underlying the absence of HCA/HCC in AAV/AAV-low-NT (AAV-NT) mice. The CR mediators 5' adenosine monophosphate-activated protein kinase (AMPK) and sirtuin-1 (SIRT1), which share activators, actions, and targets, were activated in AAV-NT mice. AMPK elicits anti-inflammatory action by inhibiting phosphorylation and activation of STAT3, a transcription factor

**FIGURE 1. Proposed mechanisms that prevent HCA/HCC in *G6pc<sup>-/-</sup>* mice receiving gene therapy**

Several signaling pathways contribute to the anti-tumorigenic liver phenotype of the AAV-NT mice. The increases in total AMPK and p-AMPK-T172 activate AMPK, which suppresses phosphorylation and activation of STAT3 signaling. The increase in hepatic  $\text{NAD}^+$  levels activates SIRT1, which suppresses NF $\kappa$ B signaling via deacetylation of the p65 subunit of NF $\kappa$ B. The down-regulation of hepatic STAT3/NF $\kappa$ B signaling leads to reduced expression of pro-inflammatory mediators and STAT3/NF $\kappa$ B targets. SIRT1 activation also negatively regulates tumor metastasis by increasing the expression of E-cadherin and reducing the expression of mesenchymal markers and the epithelial-mesenchymal transition transcription factors. The increase in E-cadherin also inhibits  $\beta$ -catenin signaling which plays a key role in the pathogenesis of HCC. CR also activates FGF21/ $\beta$ -klotho signaling, which decreases the expression of  $\beta$ -catenin targets and prevents hepatocarcinogenesis.

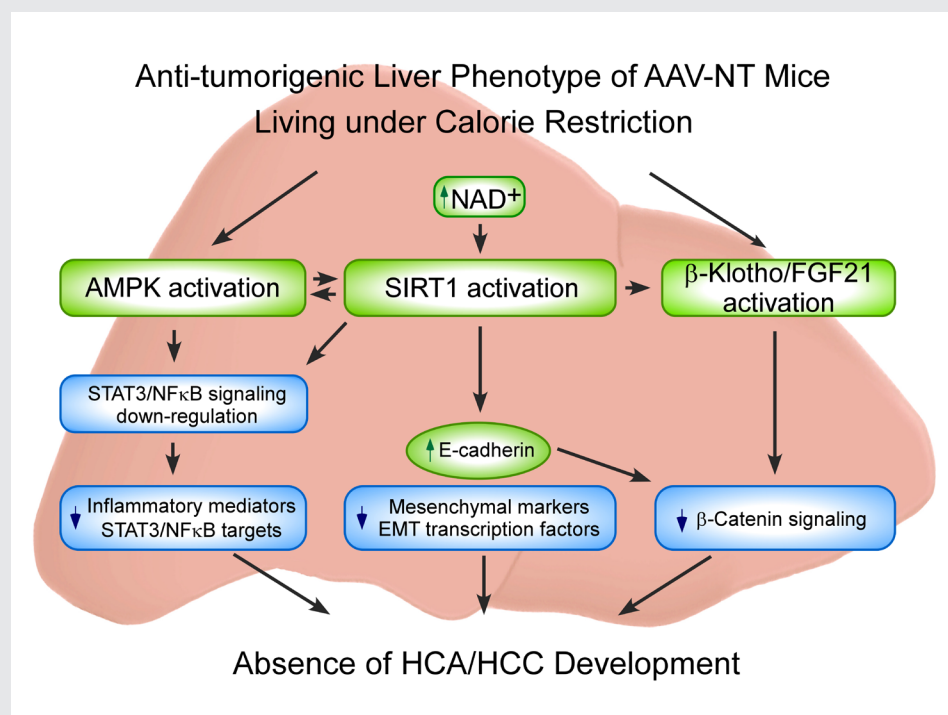

that promotes cancer-causing inflammation. SIRT1 represses NFκB activity via deacetylates of NFκB-p65, a transcription factor that promotes inflammation-associated cancer. The signaling by STAT3 and NF-κB is highly interconnected. Together they regulate several genes involved in tumor proliferation, survival, and invasion. In AAV-NT mice, hepatic levels of active p-STAT3-Y705 and ac-NFκB-p65-K310 were reduced. SIRT1 also inhibits cancer metastasis. We showed that the expression of mesenchymal markers, STAT3 targets, NFκB targets, and β-catenin targets, which all promote tumorigenesis, were also reduced. AAV-NT mice also expressed increased levels of E-cadherin, FGF21, and the tumor suppressor β-klotho. Importantly, treating the mice with the SIRT1 inhibitor EX-527 markedly reversed many of the anti-tumorigenic pathways. In summary, activation of hepatic AMPK/SIRT1 and FGF21/β-klotho signaling combined with down-regulation of STAT3 and NFκB signaling underlie the absence of HCA/HCC in AAV-NT mice.

## Molecular mechanisms underlying the improved metabolic phenotype in GSD-Ia mice receiving gene therapy

We showed that gene therapy mediated by rAAV8-G6PC, a recombinant adeno-associated virus pseudotype 2/8 (rAAV8) vector expressing human G6Pase-alpha directed by the human G6PC promoter/enhancer, normalizes blood glucose homeostasis in *G6pc* knockout (*G6pc*<sup>-/-</sup>) mice for 70-90 weeks. The treated *G6pc*<sup>-/-</sup> mice (AAV mice) expressing 5 units or more of hepatic G6Pase-alpha activity (3% or more of normal hepatic G6Pase-alpha activity) maintain glucose homeostasis, show no evidence of hepatocellular adenoma (HCA)/carcinoma (HCC), and are protected against age-related insulin resistance or obesity. We then undertook studies to delineate the molecular mechanisms underlying this beneficial metabolic phenotype. Studies showed that mice over-expressing hepatic carbohydrate-responsive element-binding protein (ChREBP) exhibit improved glucose and lipid metabolism, resulting from activation of the protein kinase Akt and increased expression of stearoyl-CoA desaturase 1 (SCD1), which converts saturated fatty acids into the beneficial mono-unsaturated fatty acids. In AAV mice, elevated concentrations of hepatic G6P stimulate hepatic ChREBP signaling, leading to increased SCD1 and activation of the protein kinases p-Akt-S473 and p-Akt-T308, consistent with activation of ChREBP signaling, as one mechanism underlying the beneficial phenotype.

We further showed that the AAV mice mimic animals living under CR. The major downstream modulators of CR are AMPK, a master regulator of energy homeostasis, and SIRT1, an NAD<sup>+</sup>-dependent deacetylase. We showed that hepatic NAD<sup>+</sup> concentrations in the AAV mice are higher than in age-matched control mice, consistent with SIRT1 activation. The AAV mice also exhibit increased protein levels of AMPK and active p-AMPK-T172. Given that aging is associated with mitochondrial dysfunction, protection of mitochondria may also contribute to the observed phenotype. Peroxisome proliferator-activated receptor-γ coactivator-1α (PGC-1α) is a master regulator of energy metabolism and mitochondrial biogenesis and plays key roles in the maintenance of mitochondrial integrity, biogenesis, and function. We showed that the expression of *PGC-1α*, which can be activated both by AMPK-mediated phosphorylation and SIRT1-mediated deacetylation, is up-regulated in the AAV mice. Moreover, protein levels of complex I to V of the mitochondrial electron transport chain are up-regulated in AAV mice. Taken together, the underlying mechanisms responsible for the beneficial metabolic phenotype correlate with activation of ChREBP and AMPK/SIRT1/PGC-1α signaling pathways in the livers of AAV mice.

## Molecular mechanisms underlying HCA and HCC in murine GSD-Ia

The most severe complications in GSD-Ia are the development of HCA and HCC of unknown etiology. Global knock-out *G6pc*<sup>-/-</sup> mice die early, well before HCA/HCC can develop, making studies of HCA/HCC mechanisms

difficult. We therefore generated liver-specific *G6pc* knock-out mice (*L-G6pc<sup>-/-</sup>*) that survive to adulthood and develop HCA. Using *L-G6pc<sup>-/-</sup>* mice, we investigated the underlying mechanisms of HCA/HCC in GSD-Ia. Studies have shown that autophagy-deficient mice develop HCA and we looked to this as a guide. We hypothesized that defective autophagy may underlie HCA/HCC development in GSD-Ia.

Autophagy can be regulated directly by SIRT1 through deacetylation of autophagy-related (ATG) proteins and indirectly through deacetylation and activation of FoxO factors, which transactivate autophagy genes. SIRT1 activity can be activated by the cofactor NAD<sup>+</sup>, but levels of NAD<sup>+</sup> were unchanged in *L-G6pc<sup>-/-</sup>* livers. The expression of SIRT1 can be suppressed by lipogenic factors such as ChREBP and peroxisome proliferator-activated receptor gamma (PPAR- $\gamma$ ) and stimulated by FoxO1 (a transcription factor that plays important roles in regulation of gluconeogenesis and glycogenolysis by insulin signaling) and PPAR- $\alpha$  in response to nutrient starvation. In the *G6pc<sup>-/-</sup>* liver, activation of ChREBP signaling was associated with increased lipogenesis and suppressed PPAR- $\alpha$  expression, leading to a marked increase in hepatic steatosis and elevated PPAR- $\gamma$  expression. The net outcome was a lower expression of SIRT1 in *G6pc<sup>-/-</sup>* livers than in controls. In addition, protein levels of FoxO3a were lower in *G6pc<sup>-/-</sup>* livers. Collectively, reduced SIRT1-FoxO signaling appears to contribute to impaired autophagy in *G6pc<sup>-/-</sup>* livers. The G6Pase- $\alpha$ -deficient liver also displays mitochondrial dysfunction characterized by a reduction in oxidative phosphorylation, lower overall mitochondrial numbers, and a decrease in functional mitochondria. The mechanism underlying mitochondrial dysfunction arises from down-regulation of hepatic SIRT1-PGC-1 $\alpha$  signaling pathway.

We further showed that the underlying mechanisms responsible for HCA/HCC formation in GSD-Ia include accumulation of polyubiquitin-binding protein (p62) aggregates, which promotes tumorigenesis, marked mitochondrial, and oxidative DNA damage. Importantly, we showed that restoration of hepatic G6Pase- $\alpha$  expression by rAAV-G6PC-mediated gene transfer normalizes autophagy deficiency and restores SIRT1-FoxO signaling in *L-G6pc<sup>-/-</sup>* mice. Taken together, our study provides the underlying mechanisms for HCA/HCC in GSD-Ia and also suggests that correction of defective autophagy by gene therapy or pharmacological intervention will prevent or slow the chronic development of HCA/HCC in human GSD-Ia patients.

## Liver-directed gene therapy for murine GSD-Ib

We showed that systemic administration of rAAV-CBA-G6PT, a rAAV8 vector expressing human G6PT directed by the chicken b-actin (CBA) promoter/CMV (cytomegalovirus) enhancer, delivered the *G6pt* transgene to the liver and normalized metabolic abnormalities in murine GSD-Ib. However, the five transduced GSD-Ib mice that lived to age 52–70 weeks expressed less than 4% of wild-type hepatic G6PT activity, and two mice developed HCA, with one undergoing malignant transformation. Studies have shown that the choice of transgene promoter not only affects targeting efficiency and tissue-specific expression but also the level of immune response or tolerance to the therapy. We therefore examined the safety and efficacy of rAAV8-G6PT, a rAAV8 vector expressing human *G6PT* directed by the tissue-specific human *G6PC* promoter/enhancer. Among the fifteen 60–78 week-old rAAV-treated *G6pt<sup>-/-</sup>* mice expressing 2–62% of wild-type hepatic G6PT activity, only one mouse expressing 6% of normal hepatic G6PT activity developed HCA. The rAAV-treated mice, including the HCA-bearing mouse, displayed normal hepatic fat storage, normal glucose tolerance profiles, and maintained normoglycemia over a 24-hour fast. The rAAV-treated mice also exhibit a leaner phenotype and are protected against age-related insulin resistance. We further showed that activation of hepatic ChREBP signaling, which improves glucose tolerance and insulin sensitivity, is one mechanism that protects the rAAV-GPE-G6PT-treated *G6pt<sup>-/-</sup>* mice against age-related obesity and insulin resistance.



## Additional Funding

- The Children's Fund for Glycogen Storage Disease Research, 2015
- Dimension Therapeutics (Cambridge, MA) under a Cooperative Research and Development Agreement (CRADA)

## Publications

1. Lin SR, Pan CJ, Mansfield BC, Chou JY. Functional analysis of mutations in a severe congenital neutropenia syndrome caused by glucose-6-phosphatase-beta deficiency. *Mol Genet Metab* 2015 114:41-45.
2. Kim GY, Lee YM, Cho JH, Pa CJ, Jun HS, Springer DA, Mansfield BC, Chou JY. Mice expressing reduced levels of hepatic glucose-6-phosphatase-a activity do not develop age-related insulin resistance and obesity. *Hum Mol Genet* 2015 24:5115-5125.
3. Chou JY, Jun HS, Mansfield BC. Type I glycogen storage diseases: disorders of the glucose-6-phosphatase/ glucose-6-phosphate transporter complexes. *J Inherit Metab Dis* 2015 38:511-519.
4. Lee YM, Kim GY, Pan CJ, Mansfield BC, Chou JY. Minimal hepatic glucose-6-phosphatase-a activity required to sustain survival and prevent hepatocellular adenoma formation in murine glycogen storage disease type Ia. *Mol Genet Metab Rep* 2015 3:28-32.

## Collaborators

- Alessandra Eva, PhD, *Istituto Giannina Gaslini, Genova, Italy*
- Luigi Varesio, PhD, *Istituto Giannina Gaslini, Genova, Italy*
- David A. Weinstein, MD, *University of Florida College of Medicine, Gainesville, FL*

## Contact

For more information, email [chou@helix.nih.gov](mailto:chou@helix.nih.gov) or visit <https://irp.nih.gov/pi/janice-chou>.

## Chromatin Remodeling and Gene Activation

Aberrant gene regulation is the basis of many disease states. Our main objective is to understand how genes are activated for transcription in the context of chromatin structure. Chromatin is not just a packaging system for DNA in eukaryotic cells—it also participates in gene regulation. The structural subunit of chromatin is the nucleosome, which contains nearly two turns of DNA coiled around a central core histone octamer. Nucleosomes are generally quite regularly spaced along the DNA, like beads on a string. Gene regulation involves either attenuation of the inherently repressive properties of nucleosomes to facilitate gene expression, or enhancement of those properties to ensure complete repression. These events are choreographed by DNA sequence-specific transcription factors (activators and repressors) and chromatin-remodeling complexes. The latter can be divided into two groups: histone or DNA-modifying enzymes that implement the “epigenetic code,” and ATP-dependent remodeling machines, which move or displace nucleosomes. Genes encoding subunits of some of these enzymes are often mutated in various cancers.

We are exploiting high-throughput technologies to obtain genome-wide maps of nucleosomes, chromatin-remodeling complexes and RNA polymerase II in budding yeast to determine what happens to nucleosomes on genes when these are activated. We find that transcription results in disruption and loss of some nucleosomes on the gene with re-positioning of the remaining nucleosomes (Figure 1). The current objectives of our yeast studies are to: (1) determine the roles of various chromatin-remodeling complexes (RSC, SWI/SNF, ISW1, ISW2, and CHD1) in chromatin organization and gene expression; (2) understand the dynamics of transcription by RNA polymerase II through chromatin *in vivo*, with an emphasis on potential regulation of the dissociation of polymerase after transcription.

Most of our work involves the use of *Saccharomyces cerevisiae* (budding yeast) as a model organism, but, through collaborations, we are now extending our studies of chromatin remodeling from yeast to mouse. Mammalian systems are much more complex and challenging than yeast. We are investigating the effects of dexamethasone on mouse-cell chromatin in a collaboration with the

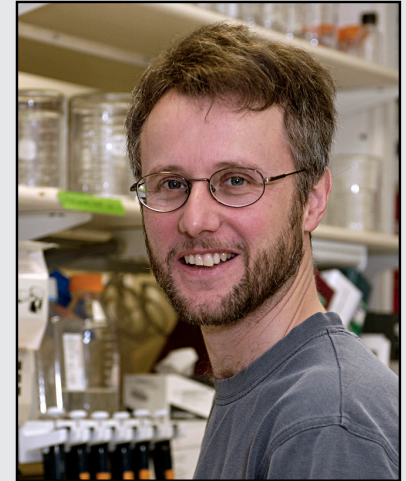

**David J. Clark, PhD, Head,**  
*Section on Chromatin and Gene  
Expression*

Peter Eriksson, PhD, *Staff Scientist*

Razvan V. Chereji, PhD, *Research  
Fellow*

Josefina Ocampo, PhD, *Visiting  
Fellow*

Sean C. Clark, MS,  
*Postbaccalaureate Fellow*

Allison F. Dennis, BS, *Graduate  
Student*

Hager lab. We are also comparing the chromatin structures of neurons, oligodendrocytes, and astrocytes in a collaboration with the Fields lab.

**FIGURE 1. Chromatin structure of a heavily transcribed gene**

The nucleosome-depleted region (NDR) at the promoter is expanded upstream to accommodate additional non-histone complexes (both H4 and H2B are partially lost). RNA polymerase II (Pol II) binds near the transcription start site (TSS) and clears the promoter rapidly (low Pol II at the TSS). Pol II levels over the remainder of the gene are high and coincide with some loss of H4 and heavy loss of H2B, resulting in sub-nucleosomal particles (tetrasomes and hexasomes). Pol II overshoots the transcript end site (TES) and accumulates about 140 bp downstream, sometimes farther ("runaway" Pol II). Accumulation of Pol II downstream of the TES implies that dissociation from DNA is relatively slow, such that more Pol II queues up behind it. Slow dissociation might facilitate transfer of Pol II back to the promoter ("recycling"), increasing the transcription rate. Adapted from Cole HA *et al. Nucl Acids Res* 2014;42:12512.

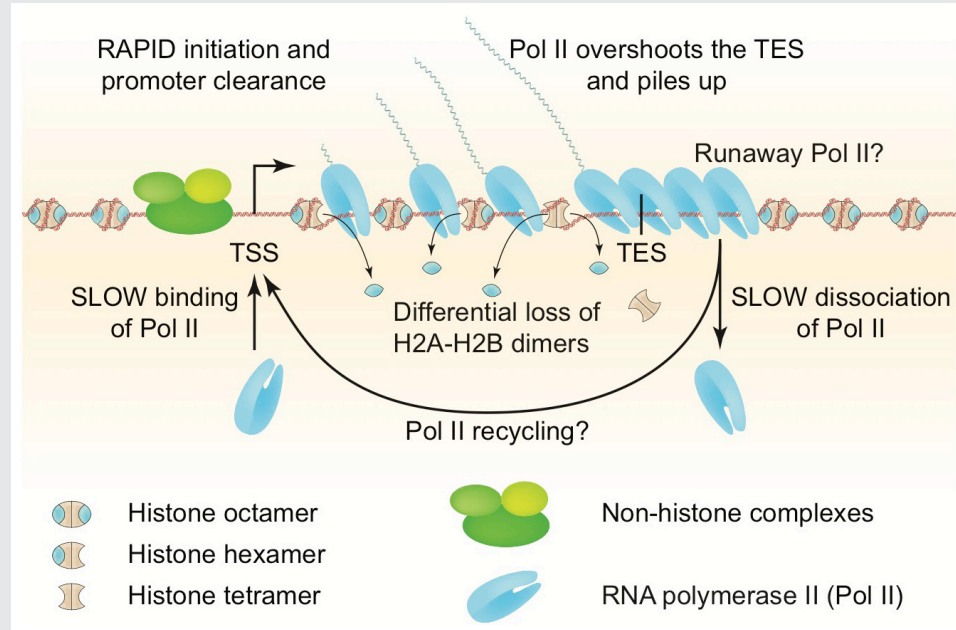

## The ISW1 and CHD1 ATP-dependent chromatin remodelers compete to set nucleosome spacing *in vivo*.

ATP-dependent chromatin-remodeling machines play a central role in gene regulation by manipulating chromatin structure. Most genes have a nucleosome-depleted region at the promoter and an array of regularly spaced nucleosomes phased relative to the transcription start site. *In vitro*, the three known yeast nucleosome-spacing enzymes (CHD1, ISW1, and ISW2) form arrays with different spacing. In this study, we used genome-wide nucleosome sequencing (MNase-seq) to determine whether these enzymes space nucleosomes differently *in vivo*. Specifically, we constructed all combinations of *isw1*, *isw2*, and *chd1* null mutants and compared their chromatin structures. We found that CHD1 and ISW1 compete to set the spacing on most genes, such that CHD1 dominates genes with shorter spacing and ISW1 dominates genes with longer spacing. In contrast, ISW2 plays a minor role, limited to transcriptionally inactive genes. Heavily transcribed genes show weak phasing and extreme spacing, either very short or very long, and are depleted of linker histone (H1). Genes with longer spacing are enriched in H1, which directs chromatin folding. We propose that CHD1 directs short spacing, resulting in eviction of H1 and chromatin unfolding, whereas ISW1 directs longer spacing, allowing H1 to bind and condense the chromatin (Reference 1). Thus, competition

between the two remodelers to set the spacing on each gene may result in a highly dynamic chromatin structure (Figure 2). We are currently testing this model.

## Genome-wide cooperation by HAT Gcn5, remodeler SWI/SNF, and chaperone Ydj1 in promoter nucleosome eviction and transcriptional activation

Gene activation generally involves nucleosome removal and/or nucleosome shifts in the promoter region. Histone chaperones, ATP-dependent nucleosome-remodeling complexes and histone acetyltransferases (HATs) have been implicated in nucleosome disassembly at promoters of particular yeast genes. However, it is unclear whether these co-factors function ubiquitously. Furthermore, the impact of nucleosome eviction at promoters on transcription genome-wide is poorly understood. In a collaboration with the Hinnebusch lab, we used chromatin immunoprecipitation (ChIP-seq) of histone H3 and RNA polymerase II (Pol II) in mutants lacking single or multiple co-factors to address these issues for about 200 genes belonging to the Gcn4 transcriptome. We find that about 70 genes exhibit marked reductions in H3 promoter occupancy on induction by amino-acid starvation. A close examination of four target genes in a panel of mutants indicated that the SWI/SNF ATP-dependent chromatin remodeler, the Gcn5 HAT, a subunit of the SAGA complex, the heat-shock protein Hsp70 co-chaperone Ydj1, and the chromatin-associated factor Yta7 are required downstream of Gcn4 binding, whereas other co-factors (the Asf1 and Nap1 histone chaperones, the Rtt109 HAT, the RSC chromatin remodeler, and the H2AZ histone variant) are dispensable for robust H3 eviction in otherwise wild-type cells. Using ChIP-seq to interrogate all 70 exemplar genes in single, double, and triple mutants, we found that Gcn5, Snf2, and Ydj1 were implicated in H3 eviction at most, but not all Gcn4 target

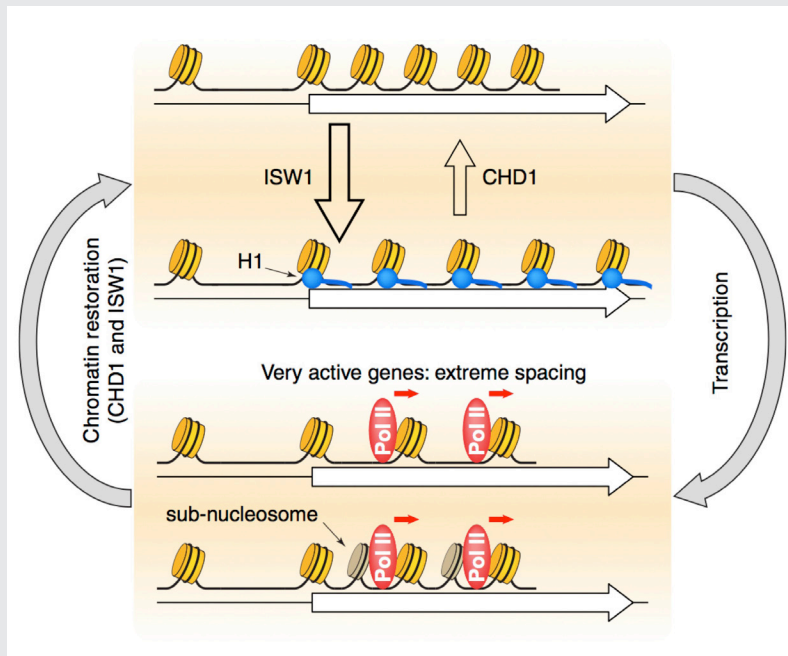

**FIGURE 2. Roles of the CHD1, ISW1, and ISW2 nucleosome spacing enzymes in creating a dynamic chromatin structure**

We propose that CHD1 and ISW1 compete to determine the spacing on most genes. Genes dominated by ISW1 have longer spacing, resulting in linkers long enough to bind to H1 (blue circles) with high affinity and thus in more condensed chromatin. Genes dominated by CHD1 have short spacing, with linkers too short for H1 binding. Competition between CHD1 and ISW1 occurs on most genes, resulting in intermediate spacing, possibly creating a highly dynamic chromatin structure. The most inactive genes are also affected by ISW2, resulting in slightly longer spacing. Heavily transcribed genes have highly disrupted chromatin, including gaps created by loss of some nucleosomes and sub-nucleosomes (darker cylinders) and resulting from displacement of H2A-H2B dimers and thus in extreme spacing.

promoters, with Gcn5 generally playing the greatest role and Ydj1 the least. Remarkably, the three co-factors cooperate similarly in H3 eviction at virtually all yeast promoters. Defective H3 eviction in co-factor mutants was coupled with reduced Pol II occupancies for the Gcn4 transcriptome and the most highly expressed un-induced genes, but the relative Pol II levels at most genes were unaffected or even elevated. The findings indicate that nucleosome eviction is crucial for robust transcription of highly expressed genes, but that other steps in gene activation are more rate-limiting for most other yeast genes (Reference 2).

## MNase-sensitive complexes in yeast: nucleosomes and non-histone barriers

Micrococcal nuclease (MNase) is commonly used to map nucleosomes genome-wide, but nucleosome maps are affected by the degree of digestion. It has been proposed that many yeast promoters are not nucleosome-free but occupied by easily digested, unstable, “fragile” nucleosomes. We analyzed the histone content of all MNase-sensitive complexes by MNase-ChIP-seq and Sonication-ChIP-seq. We found that yeast promoters are predominantly bound by non-histone protein complexes, with little evidence for binding by fragile nucleosomes. We did detect MNase-sensitive nucleosomes elsewhere in the genome, including at transcription termination sites. However, they have high A/T content, suggesting that MNase sensitivity does not indicate instability but a preference of MNase for A/T-rich DNA, such that A/T-rich nucleosomes are digested faster than G/C-rich nucleosomes. We confirmed our observations by analyzing ChIP-exo, chemical mapping, and ATAC-seq data from other laboratories. Thus, histone ChIP-seq experiments are essential to distinguish nucleosomes from other DNA-binding proteins that protect against MNase. A manuscript describing this work has been submitted (Chereji RV, Ocampo J, Clark DJ).

## Chromatin remodeling in neurons and oligodendroglia

The aim of this project, a collaboration with the Fields lab, is to determine the relationship between chromatin organization and gene expression in dorsal root ganglion neurons and oligodendroglial cells. Neuronal chromatin is remarkably atypical: the linker DNA between nucleosomes is much shorter than in other cell types, including oligodendroglial cells, and neurons are deficient in histone H1. The global organization of neuronal chromatin is therefore very different from other cells, but the significance of such organization is unknown. We are testing the relationship between global chromatin organization and transcription. We have mapped nucleosomes genome-wide in isolated mouse neurons and in oligodendroglial cells, using paired-end sequencing, and measured gene expression by RNAseq. We are now correlating their chromatin structures with transcriptional activity. Our experiments should provide insight into why neuronal chromatin organization is so different from that of other cells, including glia.

## Publications

1. Ocampo J, Chereji RV, Eriksson PR, Clark DJ. The ISW1 and CHD1 ATP-dependent chromatin remodelers compete to set nucleosome spacing in vivo. *Nucl Acids Res* 2016 44:4625-4635.
2. Qiu H, Chereji RV, Hu C, Cole HA, Rawal Y, Clark DJ, Hinnebusch AG. Genome-wide cooperation by HAT Gcn5, remodeler SWI/SNF and chaperone Ydj1 in promoter nucleosome eviction and transcriptional activation. *Genome Res* 2016 26:211-225.
3. Ocampo J, Clark DJ. A positive twist to the centromeric nucleosome. *Cell Rep* 2015 13:645-646.
4. Gerasimova NS, Pestov NA, Kulaeva OI, Clark DJ, Studitsky VM. Transcription-induced DNA supercoiling: new roles of intranucleosomal DNA loops in DNA repair and transcription. *Transcription* 2016 7:91-95.

5. Ocampo J, Cui F, Zhurkin VB, Clark DJ. The proto-chromatosome — a fundamental subunit of chromatin? *Nucleus* 2016 7:382-387.

## Collaborators

- Feng Cui, PhD, *Rochester Institute of Technology, Rochester, NY*
- Douglas Fields, PhD, *Section on Nervous System Development and Plasticity, NICHD, Bethesda, MD*
- Gordon L. Hager, PhD, *Laboratory of Receptor Biology and Gene Expression, Center for Cancer Research, NCI, Bethesda, MD*
- Alan G. Hinnebusch, PhD, *Section on Nutrient Control of Gene Expression, NICHD, Bethesda, MD*
- James Iben, PhD, *Section on Molecular Dysmorphology, NICHD, Bethesda, MD*
- Philip Lee, PhD, *Section on Nervous System Development and Plasticity, NICHD, Bethesda, MD*
- Vasily M. Studitsky, PhD, *Fox Chase Cancer Center, Temple University Health System, Philadelphia, PA*
- Victor Zhurkin, PhD, *Laboratory of Cell Biology, Center for Cancer Research, NCI, Bethesda, MD*

## Contact

For more information, email [clarkda@mail.nih.gov](mailto:clarkda@mail.nih.gov) or visit <http://clarklab.nichd.nih.gov>.

## Physiological, Biochemical, and Molecular-Genetic Events Governing the Recognition and Resolution of RNA/DNA Hybrids

Damaged DNA is a leading cause of many human diseases and disorders. We study the formation and resolution of RNA/DNA hybrids, which occur during DNA and RNA synthesis. Such hybrid molecules may lead to increased DNA damage but may also play critical roles in normal cellular processes. We are interested in how RNA/DNA hybrids are resolved and in the role that ribonucleases H (RNases H) play in their elimination. Two classes of RNases H, Class I and Class II, are present in most organisms.

**Human disorders related to RNases H1 and H2.** Human patients with mutations in *RNASEH1* exhibit a typical mitochondrial muscular phenotype (Reference 1). Our studies were the first to show that RNase H1 is essential for maintenance of mitochondrial DNA. Mice deleted for the *Rnaseh1* gene arrest embryonic development at day 8.5 as a result of failure to amplify mitochondrial DNA (Reference 2). Aicardi-Goutières syndrome (AGS), a severe neurological disorder with symptoms appearing at or soon after birth, can be caused by defective human RNase H2 (Reference 3). We are examining mouse models of AGS to gain insight into the human disorder. To understand the mechanisms, functions, substrates, and basic molecular genetics of RNases H, we employ molecular-genetic and biochemical tools in yeast and mouse models.

### Contrasts between Class I and Class II RNases H

Many of our investigations over the past few years focused on RNase H1. RNase H1 recognizes the 2'-OH of four consecutive ribonucleotides, while the DNA strand is distorted to fit into a pocket of the enzyme. Thus, the enzyme requires more than one ribonucleotide for cleavage of RNA in RNA/DNA hybrids. RNases H1 consist of a single polypeptide in both eukaryotes and prokaryotes. In contrast, RNase H2 is a complex of three distinct polypeptides in eukaryotes but is a single polypeptide in prokaryotes. The catalytic subunit of the hetero-trimeric RNase H2 of eukaryotes is similar in its primary amino-acid sequence to the prokaryotic enzyme. RNase H2 can recognize and cleave both RNA/DNA hybrids and a single ribonucleotide (Reference 4) or the transition from the ribonucleotide in the case of RNA-primed DNA

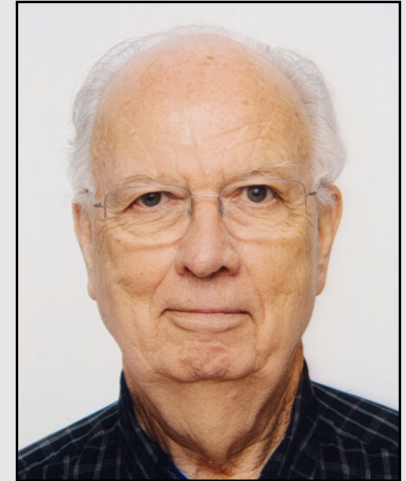

**Robert J. Crouch, PhD, Head,**  
*Section on Formation of RNA*  
Susana M. Cerritelli, PhD, *Staff*  
*Scientist*

Naushaba Hasin, PhD,  
*Postdoctoral Fellow*

Ryo Uehara, PhD, *Postdoctoral*  
*Fellow*

Kiran Sakhuja, MS, MSc, *Biologist*

Kenji Kojima, PhD, *Research*  
*Collaborator*

synthesis (e.g., *rrrrrDDDD* in DNA—italics indicate transition from ribonucleotide to deoxyribonucleotide).

Several types of RNA/DNA hybrid structures are formed, which are processed differently. Simple RNA/DNA hybrids consist of one strand of RNA paired with one strand of DNA. The HIV–AIDS reverse transcriptase (RT) forms such hybrids when copying its genomic RNA into DNA. The RT also has an RNase H domain that is structurally and functionally similar to the class I cellular RNase H and is necessary for several steps of viral DNA synthesis. R-loop hybrids have two separated DNA strands, with one hybridized to RNA while the other is in single-stranded form. These structures sometimes form during transcription and can lead to chromosomal breakage. However, they are also part of the normal recombination process of switching (recombination) from one form of immunoglobulin to another, resulting in different isoforms of antibodies. Another form of hybrid is single or multiple ribonucleotides incorporated into DNA during replication (Reference 4). The first two types of hybrid are substrates for class I and II RNases H. The third is uniquely recognized by type 2 RNases H.

## Dual activities of RNase H2 and Aicardi–Goutières syndrome

Eukaryotic RNases H2 recognize and resolve RNA hybridized or covalently attached to DNA—two chemically distinct structures—using the same catalytic mechanism for hydrolysis. RNase H2 mutations that reduce catalytic activity, or fail to properly interact with *in vivo* substrates, cause Aicardi–Goutières syndrome (AGS). Mutations in seven genes are known to cause AGS, with more than 50% of AGS patients having mutations in any of the three subunits of RNase H2. We previously expressed (in *Escherichia coli*) and purified human RNases H2 with mutations corresponding to several of those seen in AGS patients, one, G37S, with significant loss of RNase H2 activity. Using the 3D structure of the human enzyme that we had determined, we could locate all known mutations in RNase H2 that cause AGS. The wide distribution of the mutations suggests that modest changes in stability, interaction with other unknown proteins, and loss of catalysis can all cause AGS. A mutation near the catalytic center of G37S–mutated RNase H2 found in some AGS patients results in low RNase H2 activity for both embedded ribonucleotides in DNA and RNA/DNA hybrids (Reference 3). We are developing mouse models of AGS to clarify which defects are associated with each RNase H2 activity. Mice bearing the G37S mutation in homozygous form are perinatal lethal, i.e., either dead at birth or die within a few hours of birth (Reference 3).

Mutations in another gene, *TREX1*, also cause AGS, and it has been shown that homozygous knockout (KO) mice are viable but die after a few weeks owing to cardiomyopathy, which can be prevented by either blocking an innate or adaptive immune response. In contrast, the G37S–mutant perinatal lethality and the fact that RNase H2 KO mice die early in embryogenesis suggest a more severe defect than that seen in *Trex1*–KO mice. We attempted to rescue the perinatal phenotype by eliminating one part of the innate immune pathway or by completely inactivating the adaptive immune response. Viability of these mice is no different than the innate or adaptive-competent mice. Perhaps, there are additional defects in G37S mice that are directly related to viability—not innate immunity. However, the expression of several interferon-stimulated genes (ISGs) is elevated in mouse embryonic fibroblasts (MEFs) derived from G37S homozygous embryos, supporting a role for innate immunity the AGS phenotype. Damaged DNA that finds its way to the cytoplasm can be sensed by cyclic GMP-AMP synthase (cGAS) producing the small molecule cGAMP, which interacts with the Sting protein, an important protein for the DNA–sensing innate immune pathway. Mice that are homozygous for G37S and deleted for the *cGAS* or *Sting* genes are mostly perinatal lethal but no longer exhibit increases in ISGs. Interestingly, a small fraction of the double G37S–*Sting* KO are viable, indicating



only limited involvement of ISGs in perinatal lethality (Reference 3). Further studies are under way, which we expect will lead us to the cause of lethality.

To distinguish the defects that persistent RNA/DNA hybrids and single ribonucleotides joined to DNA caused *in vivo*, Hyongi Chon, a former postdoctoral fellow, rationally designed a modified RNase H2 to make an enzyme unable to cleave single ribonucleotides embedded in DNA but that retains RNA/DNA hydrolytic activity. The mutant enzyme, which we call RED (Ribonucleotide Excision Deficient), resolves RNA/DNA hybrids, which are substrates of both RNase H1 and RNase H2. Unlike the mouse and human RNases H2, RNase H2 activity is not required in the yeast *Saccharomyces cerevisiae*. Taking advantage of the ease with which genetic mutation studies can be conducted in yeast, we found that, in yeast producing the RNase H2<sup>RED</sup> enzyme, embedded ribonucleotides (rNMPs) were left in DNA but that the enzyme was potent in removing RNA from RNA/DNA hybrids.

Embryonic lethality of mice *Rnaseh2b*-KO stains has been attributed to accumulation of rNMPs in DNA, but lethality could result from loss of RNA/DNA hydrolysis or a combination of both rNMP and RNA/DNA hydrolysis defects. To distinguish among the possible causes of embryonic lethality, we generated a mouse that produces the RNase H2<sup>RED</sup> enzyme. Mouse embryonic fibroblasts (MEFs) derived from *Rnaseh2*<sup>RED</sup> mice have the same high level of rNMPs as seen in *Rnaseh2b*-KO MEFs. Interestingly, the *Rnaseh2*<sup>RED</sup> mice also die around the same time as the *Rnaseh2b*-KO mice. Therefore, lethality of the KO and RED RNase H2 mouse strains lead to embryonic death. We are continuing to analyze these mice and embryos to understand the relationship between early embryonic lethality and the innate immune character of AGS.

## Steric gate in pol eta limits incorporation of rNMPs during DNA replication.

DNA polymerases are able to limit incorporation of ribonucleotides into DNA by sterically limiting binding of the closely related ribonucleoside triphosphates (rNTPs). However, the cellular concentrations of rNTPs are substantially greater than dNTPs, and it is now clear that all three replicative DNA polymerases do synthesize DNA containing rNMPs. Together with the Woodgate lab, we examined DNA polymerase eta (pol eta), the DNA polymerase important for repair of UV-damaged DNA (Reference 5). Based on other DNA pol steric-gate binding sites, we identified residue Phe35 as a candidate amino acid limiting incorporation of rNMPs in DNA, for discrimination between rNTPs and dNTPs. Substitution of an Ala for Phe35 opened the active site, allowing incorporation rNMPs. Employing the mutation F35A in pol eta together with the mutated RNase H2<sup>RED</sup>, we were able to show that rNMPs are incorporated into DNA generating 2–5 base-pair (bp) deletions in short repetitive sequences characteristically found in RNase H2-null mutations. The defect in RNase H2<sup>RED</sup> permits us to conclude that the mutations are the result of single rNMPs in DNA but not of RNA/DNA hybrids, because RNase H2<sup>RED</sup> retains the ability to hydrolyze RNA of RNA/DNA hybrids. Interestingly, we detected another, new type of mutation in which a deletion of one base pair in a run of seven thymines is much more prevalent than the 2–5 bp deletions. In addition, the overall mutation frequency is lower in the pol eta wild-type strain without active RNase H2. We believe that this is a consequence of recognition of single rNMPs in DNA by the mismatch repair pathway, providing another opportunity to repair any mistakes during UV repair by pol eta.

## Mitochondrial DNA and RNase H1 in the mouse

During embryonic development, RNase H1 is required for progress beyond day E8.5 (References 1 and 2). A single transcript of the mouse *Rnaseh1* gene is translated to make two nearly identical proteins, one

localizing to the nucleus and the other to the mitochondrion. We previously showed that the *Rnaseh1*-deleted embryos fail to amplify mtDNA (mitochondrial DNA), causing developmental arrest, whereas nuclear DNA replicated normally in *Rnaseh1*-KO embryos. We are examining loss of the *Rnaseh1* gene during B cell development to follow the process of RNase H1 depletion in a simpler system. Following conditional deletion of *Rnaseh1* at an early stage of B cell development in mouse B cells, we found that resting, naive B cells are formed but that they are unable to become activated to class-switch to other isotypes (e.g., IgG) and that sera from such mice have a major deficit in antibodies. We are currently determining whether the loss of mitochondrial DNA is the explanation for the inability of the resting B cells to be completely activated, as well as what changes in mRNA levels differ between the conditional KO and WT *Rnaseh1* genes.

J. Brad Holmes, a former graduate student in the NIH-Cambridge graduate student program, co-mentored by myself and Ian Holt, examined the roles of RNase H1 in mitochondrial DNA replication by using, among other techniques, two-dimensional gel analysis of intermediates. Our findings thus far indicate that elevated expression of RNase H1 in mitochondria alters mtDNA replication. In addition, data obtained by Holmes, supporting the existence of RNA/DNA hybrids as replication intermediates, indicate that RNase H1 is important for the removal of RNA primers of mtDNA replication. We concluded that the absence of RNase H1 activity results in accumulation of RNA from the Light Strand Promoter (LSP) fused to DNA, a result that clearly indicates that a transcript from LSP serves to initiate DNA replication of the “H” strand origin of replication (oriH) (Reference 2).

Replication and transcription of mitochondrial DNA are intimately associated with a control region, a displacement D-loop. The loop has a short 7S DNA that is hydrogen-bonded to one strand, thereby displacing the third strand in this region. We recently reported that there is an R-loop complementary to the other (displaced) DNA strand of the control region (Reference 1). The D- and R-loops are independent, i.e., there are few if any four-stranded molecules. The control-region R-loops are potential substrates for RNase H1. In cells with a pathological mutation in *RNASEH1*, R-loops are less abundant in the control region, and mitochondrial DNA is aggregated. The findings implicate RNA and RNase H1 in the physical separation of mitochondrial DNA.

## Publications

1. Akmana G, Desai R, Bailey LJ, Yasukawab T, Rosa ID, Durigon R, Holmes JB, Moss CF, Mennuni M, Houlden H, Crouch RJ, Hanna MG, Pitceathly RDS, Spinazzola A, Holt IJ. Pathological ribonuclease H1 causes R-loop depletion and aberrant DNA segregation in mitochondria. *Proc Natl Acad Sci USA* 2016 113:E4276-E4285.
2. Holmes JB, Akman G, Wood SR, Sakhuja K, Cerritelli SM, Moss C, Bowmaker MR, Jacobs HT, Crouch RJ, Holt IJ. Primer retention owing to the absence of RNase H1 is catastrophic for mitochondrial DNA replication. *Proc Natl Acad Sci USA* 2015 112:9334-9339.
3. Pokatayev V, Hasin N, Chon H, Cerritelli SM, Yan N, Crouch RJ. RNase H2 catalytic core Aicardi-Goutières syndrome-related mutant invokes cGAS-STING innate immune sensing pathway in mice. *J Exp Med* 2016 213:329-336.
4. Cerritelli SM, Crouch RJ. The balancing act of ribonucleotides in DNA. *Trends Biochem Sci* 2016 41:434-445.
5. Donigan KA, Cerritelli SM, McDonald JP, Vaisman A, Crouch RJ, Woodgate R. Unlocking the steric gate of DNA polymerase eta leads to increased genomic instability in *Saccharomyces cerevisiae*. *DNA Repair* 2015 35:1-12.

## Collaborators

- Patricia J. Gearhart, PhD, *Laboratory of Molecular Biology and Immunology, NIA, Baltimore, MD*
- Ian Holt, PhD, *MRC-Mill Hill, London, United Kingdom*
- Herbert C. Morse, MD, *Laboratory of Immunopathology, NIAID, Bethesda, MD*
- Roger Woodgate, PhD, *Section on DNA Replication, Repair, and Mutagenesis, NICHD, Bethesda, MD*
- Nan Yan, PhD, *UT Southwestern Medical Center, Dallas, TX*

## Contact

For more information, email [crouchr@helix.nih.gov](mailto:crouchr@helix.nih.gov) or visit <http://sfr.nichd.nih.gov>.

## Chromosome Segregation in Higher Eukaryotes

We are interested in mechanisms of chromosome segregation, defects in which lead to aneuploidy, that is, an abnormal number of chromosomes. Several common birth defects, such as Down's syndrome, result from aneuploidy arising during meiotic cell divisions. Moreover, aneuploidy arising from mitotic divisions is a hallmark of many types of solid tumors. During interphase, chromosomes are enclosed within nuclei, and exchange of all molecules between this compartment and the rest of the cell occurs through nuclear pore complexes (NPCs). Surprisingly, NPC proteins and proteins involved in trafficking of molecules into and out of the nucleus have important roles in chromosome segregation; we are investigating these roles at a molecular level. Our studies have concentrated on a GTPase called Ran and on a family of small ubiquitin-like modifiers (SUMOs), which are indispensable for mitotic chromosome segregation.

We also recently reported that the IRBIT protein is an inhibitor of ribonucleotide reductase; IRBIT works through a novel mechanism and is vital for genomic integrity.

The ultimate goals of our studies are to understand how these pathways enable accurate chromosome segregation and to discover how they are coordinated with each other and with other aspects of cell physiology.

### Mitotic roles of nuclear pore complex proteins

NPCs consist of about thirty distinct proteins called nucleoporins. Kinetochores are proteinaceous structures that assemble at the centromere of each sister chromatid during mitosis and serve as sites of spindle microtubule attachment. The relationship between NPCs and mitotic kinetochores is surprisingly intimate but poorly understood. During interphase, several kinetochore proteins stably bind to NPCs (e.g., Mad1, Mad2, Mps1). During mitosis, metazoan NPCs disassemble, and at least a third of nucleoporins, including the RanBP2 complex and the Nup107-160 complex, associate with kinetochores. We showed that the complexes play important roles in kinetochore function. Additional nucleoporins that do not associate with kinetochores have also been shown to have important mitotic roles, including Nup214, Nup98, and TPR.



**Mary Dasso, PhD, Head, Section on Cell Cycle Regulation**

Alexei Arnaoutov, PhD, *Staff Scientist*

Vasilisa Aksenova, PhD, *Visiting Fellow*

Sarine Markossian, PhD, *Visiting Fellow*

Maia Ouspenskaia, DVM, *Biologist*

Shane Chen, PhD, *Postdoctoral Intramural Research Training Award Fellow*

Saroj Regmi, PhD, *Postdoctoral Intramural Research Training Award Fellow*

Joseph Bareille, BA, *Predoctoral Visiting Fellow*

Ka Chun Yau, BS, *Predoctoral Visiting Fellow*

Carlos Echeverria, BS, *Postbaccalaureate Intramural Research Training Award Fellow*

Alexandra Smith, BA, *Postbaccalaureate Intramural Research Training Award Fellow*

Elizabeth Turcotte, BA, BS, *Postbaccalaureate Intramural Research Training Award Fellow*

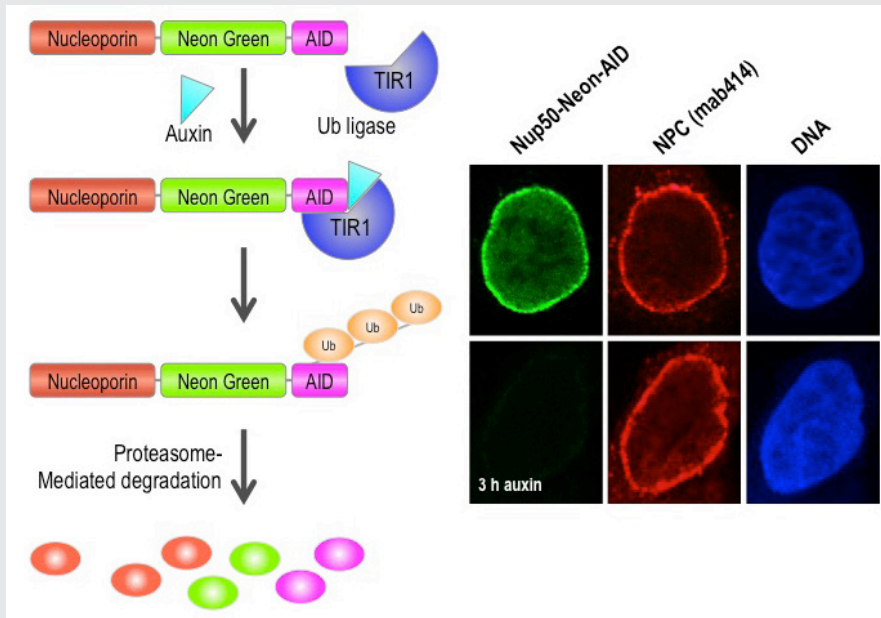

**FIGURE 1. Auxin-induced degradation of AID-tagged nucleoporins**

Cells expressing the TIR1 protein recognize proteins tagged with auxin-induced degron (AID) domains upon the addition of the plant hormone auxin. This leads to their rapid ubiquitination and destruction. We took advantage of this system by homozygously targeting endogenous nucleoporin genes with the AID tag and a fluorescent marker (neon green) in TIR1-expressing DLD1 cells. As shown on the right for the nucleoporin Nup50, we observe rapid and uniform degradation after auxin addition (left panels). Note that the nuclear pore is not generally disrupted, as indicated by staining with an antibody that recognizes a family of nucleoporins (mab414, middle panels).

The dual role of nucleoporins in controlling nuclear transport in interphase and spindle assembly in mitosis makes it difficult to precisely study their mitotic role. Nucleoporin depletion by RNAi knockdown both disrupts nuclear transport and, in many cases, causes cells to arrest in mitosis with disrupted kinetochore structures. Given that nucleoporins are long-lived proteins, a fast-reacting protein degradation system that depletes proteins at a post-translational level would be a preferable method to study their activities at discrete points during the cell cycle. To address this problem, we are currently constructing and testing auxin-induced degron (AID)-tagged lines for each of the human nucleoporin proteins in human cells that stably express the Transport Inhibitor Response 1 (TIR1) protein. Auxin family hormones bind to TIR and promote its interaction with the AID domain. TIR acts as a substrate-recognition subunit for ubiquitination by the ubiquitin ligase SCF, resulting in rapid (within 30 min) auxin-dependent proteasomal degradation of AID-tagged substrates in a manner that is reversible and tunable (Figure 1). By eliciting programmed degradation of nucleoporins at different cell-cycle stages, their functions in interphase and mitosis can be differentiated and characterized.

We are validating each of the AID-tagged lines to ensure they are homozygously tagged for each nucleoporin and that the tag moiety does not disrupt function in the absence of auxin. These tests include assays of cell proliferation, chromosome segregation, and nuclear trafficking (Figure 2). After validation, we plan to analyze the roles of individual nucleoporins and of nucleoporin subcomplexes in kinetochore function, mitotic progression, and spindle assembly.

## Mitotic regulation of the Ran GTPase

Ran is a Ras-family GTPase that plays critical roles in many cellular processes, including nucleo-cytoplasmic transport, nuclear envelope assembly, and mitotic spindle assembly. Ran alternates between GDP- and GTP-

**FIGURE 2. AID tagging of nucleoporins does not disrupt nuclear trafficking in the absence of auxin.**

In order to validate the study of tagged nucleoporins, we assayed the capacity of cells expressing these proteins to import a model substrate that is imported to the nucleus by the transport receptor importin beta (A). Cell lines with tagged nucleoporins Nup50 (B) or Nup153 (C) show import rates similar to DLD1 parental cell lines. For both nucleoporins (D, E), import rates are slower after auxin addition (dotted lines) than in the absence of auxin (solid lines).

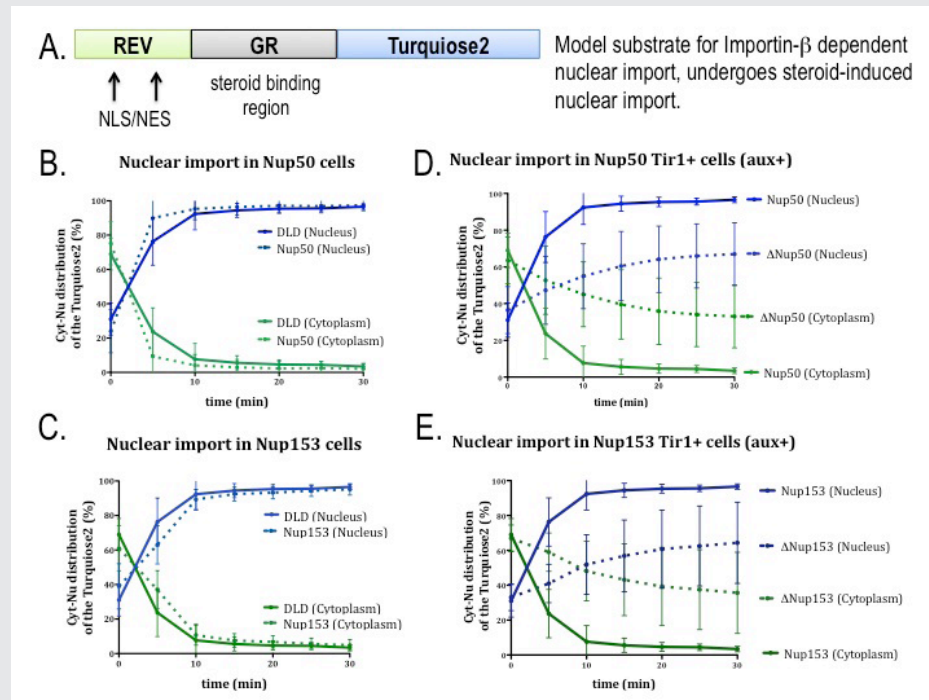

bound forms. In interphase cells, GTP-bound Ran (Ran-GTP) is the major form in nucleus while GDP-bound Ran (Ran-GDP) is the predominant form in cytoplasm. The asymmetrical distribution of Ran-GTP and Ran-GDP drives cargo transport between the nucleus and cytoplasm through karyopherins, a family of nuclear transport carrier proteins that bind to Ran-GTP. In mitosis, after nuclear envelope breakdown, Ran-GTP is concentrated in the region close to mitotic chromatin, while Ran-GDP is the major form distal to chromatin. The Ran-GTP gradient guides mitotic spindle assembly by releasing spindle assembly factors (SAFs) from karyopherins based on local Ran-GTP concentrations. In cells, the conversion of Ran-GDP to Ran-GTP is catalyzed by a Ran-specific guanine exchange factor (RanGEF) called RCC1 (Regulator of chromosome condensation 1) in vertebrates. The capacity of RCC1 to bind to chromatin establishes the asymmetrical distribution of Ran-GTP in interphase as well as the chromatin-centered Ran-GTP gradient in mitosis. Interestingly, RCC1's association with chromatin is not static during the cell cycle and is regulated in a particularly dramatic fashion during anaphase in vertebrate systems. The regulation has not been correlated with post-translational modifications of RCC1, and the underlying molecular mechanism has not been reported.

RanBP1 is a highly conserved Ran-GTP-binding protein that acts as co-activator of RanGAP1 and can form a heterotrimeric complex with Ran and RCC1 *in vitro*. We found that RCC1 not associated with chromosomes during mitosis is sequestered and inhibited in RCC1/Ran/RanBP1 heterotrimeric complexes and that the sequestration is crucial for normal mitotic spindle assembly. In addition, RanBP1 complex formation competes with chromatin binding to regulate the distribution of RCC1 between the chromatin-associated and soluble fractions. Moreover, we identified a cell cycle-dependent phosphorylation on RanBP1 that modulates RCC1/Ran/RanBP1 heterotrimeric complex assembly and releases RCC1 to bind to chromatin; the phosphorylation is directly responsible for controlling RCC1 dynamics during anaphase. Together, our findings demonstrate novel

roles of RanBP1 in spindle assembly and RCC1 regulation in mitosis. We are currently extending these findings to analyze whether RanBP1 plays an analogous role in mammalian cells during mitosis.

## SUMO–family small ubiquitin–like modifiers in higher eukaryotes

SUMOs are ubiquitin-like proteins (Ubls) that become conjugated to substrates through a pathway that is biochemically similar to ubiquitination (Figure 3). SUMOylation is involved in many cellular processes, including DNA metabolism, gene expression, and cell-cycle progression. Vertebrate cells express three major SUMO paralogs (SUMO-1–3): mature SUMO-2 and SUMO-3 are 95% identical, while SUMO-1 is 45% identical to SUMO-2 or SUMO-3 (where they are functionally indistinguishable, we collectively call SUMO-2 and SUMO-3 SUMO-2/3). Like ubiquitin, SUMO-2/3 can be assembled into polymeric chains through the sequential conjugation of SUMOs to each other. Many SUMOylation substrates have been identified. SUMOylation promotes a variety of fates for individual targets, dependent upon the protein itself, the conjugated paralog, and whether the conjugated species contains a single SUMO or SUMO chains.

SUMOylation is dynamic owing to rapid turnover of conjugated species by SUMO proteases. Both post-translational processing of SUMO polypeptides and deSUMOylation are mediated by the same family of proteases, which play a pivotal role in determining the spectrum of SUMOylated species. This group of proteases is called Ubl-specific proteases (Ulp) in yeast and Sentrin-specific proteases (SENp) in vertebrates.

**FIGURE 3. The SUMO pathway**

SUMO proteins are post-translationally processed (step 1). Processed SUMO polypeptides possess a C-terminal diglycine motif, which is activated to form an ATP-dependent thioester linkage with the SUMO E1 enzyme, the Aos1/Uba2 heterodimer (step 2). The activated SUMO is transferred to thioester linkage on a conserved cysteine of the SUMO E2 enzyme Ubc9 (step 3). Finally, the activated SUMO becomes covalently linked through an isopeptide bond to lysine residues within cellular target proteins, a reaction that is typically promoted by SUMO ligases (E3 enzymes) acting in conjunction with Ubc9 (step 4). For some substrates, additional SUMOs can be added to form SUMO chains that can act as a signal for proteolytic degradation (step 5). Both mono-SUMOylation (step 6) and poly-SUMOylation (step 7) can be reversed by a family of SUMO-specific proteases that are also major catalysts of post-translational SUMO processing, called UlpS (Ubiquitin-like protein proteases) in yeast and SENPs (Sentrin-specific protease) in vertebrates. The inserted table provides the names of proteins involved in each of these steps in budding yeast and human cells. Note that many of these enzymes (Ubc9, RanBP2, Ulp1, SENP1, SENP2) associate to the nuclear pore complex.

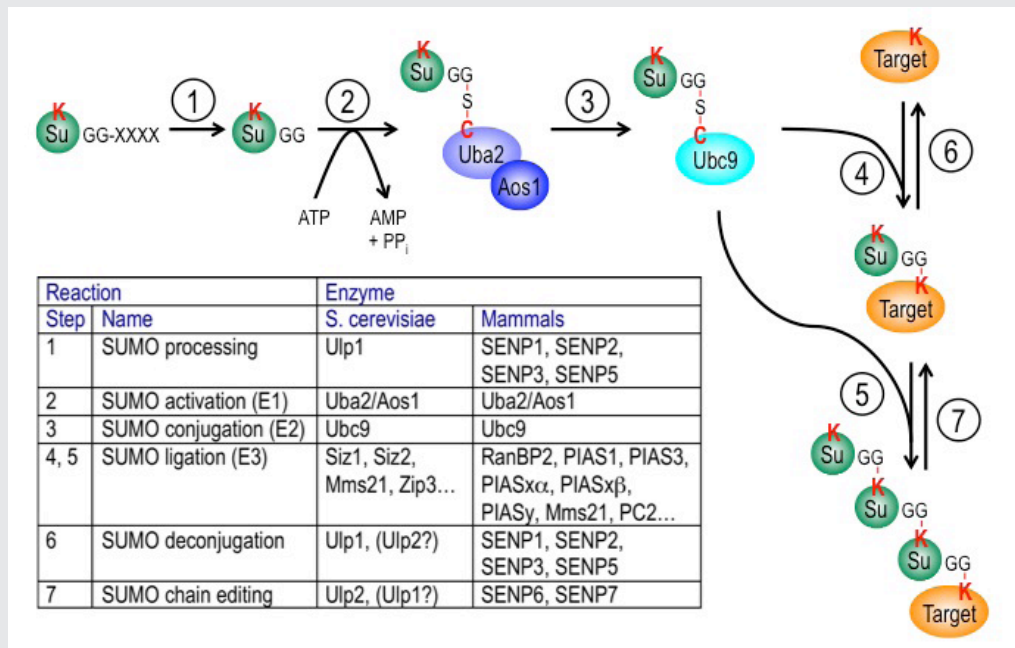
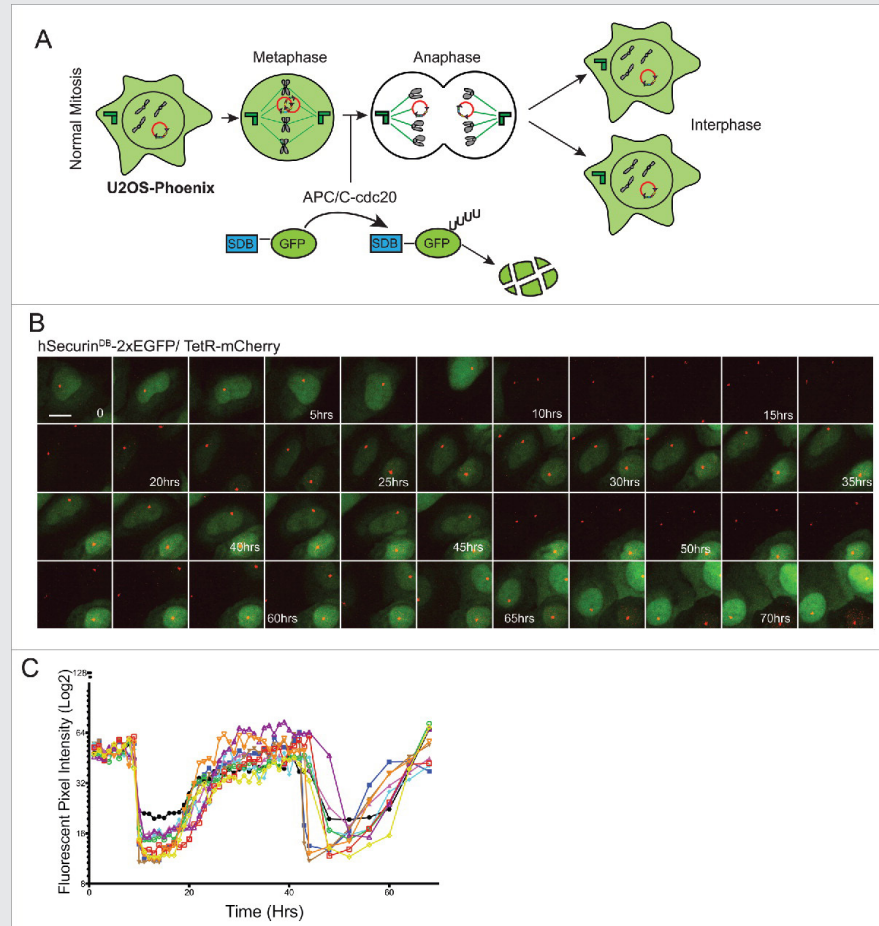

**FIGURE 4. GFP expression in U2OS-Phoenix cells is coupled to the cell cycle.**

A) Cartoon depicting U2OS-Phoenix cells undergoing one round of error-free mitosis. At the onset of anaphase, active APC/C-cdc20 recognizes and ubiquitinates DB-containing proteins, promoting their degradation. Thus, hSecurinDB-2xeGFP fusions expressed from HACs are rapidly degraded at the onset of anaphase, and re-accumulate in the two daughter cells after G1 phase.

B) Still images from a live cell-imaging experiment following hSecurinDB-2xGFP and TetR-mCherry signals in U2OS-Phoenix cells, using a spinning disc confocal microscope. The images follow one cell in two rounds of consecutive mitosis. The GFP levels in the imaged cell and its daughter are coupled to the cell cycle. Size bars = 30  $\mu\text{m}$ .

C) The mean fluorescent intensity of the GFP signal was quantified in 10 cells from movies such as in (B) and plotted against time.



There are two yeast Ulp (Ulp1p and Ulp2p/Smt4p) and six mammalian SENPs (SENP1, SENP2, SENP3, SENP5, SENP6, and SENP7). SENP1, SENP2, SENP3, and SENP5 form a Ulp1p-related sub-family, while SENP6 and SENP7 are more closely related to Ulp2p. Yeast Ulp1p has important roles in mitotic progression and chromosome segregation. We defined the enzymatic specificity of the vertebrate SENP proteins and analyzed their key biological roles.

Ulp1p localizes to NPCs, is encoded by an essential gene, and is important for SUMO processing, nucleocytoplasmic trafficking, and late steps in the ribosome biogenesis pathway. Humans possess two NPC-associated SENPs: SENP1 and SENP2. While SENP2 is dispensable for cell division, mammalian SENP1 was recently shown to play an essential role in mitotic progression. We are currently analyzing AID-tagged alleles of both SENP1 and SENP2 to assess their roles in both interphase (nuclear trafficking and gene expression) and during mitosis (kinetochore function and mitotic progression), as well as their dependence upon individual nucleoporins for their targeting to the interphase NPC.

## Phosphorylation of *Xenopus* p31<sup>comet</sup> by IKK-beta potentiates mitotic checkpoint exit.

Given that it prevents chromosome mis-segregation and averts genomic instability, the spindle assembly



checkpoint (SAC) is among the most important cellular surveillance pathways. To do this, the SAC inhibits premature separation of mitotic sister chromatids by monitoring interactions between kinetochores (KTs) and spindle microtubules (MTs). SAC components are essential in vertebrate cells because organisms that undergo open mitosis must re-establish KT-MT attachments after nuclear envelope breakdown (NEBD) in each cell division. During the process, unattached KT-MT attachments transiently invoke the SAC during the interval between NEBD and MT attachment, so that subsequent SAC silencing plays a key role in determining the timing of anaphase onset. While SAC silencing is thus critical for mitotic progression in metazoan cells, it remains poorly understood. Found in higher eukaryotes, the p31<sup>comet</sup> protein plays an important role in SAC silencing. We used *Xenopus* egg extracts (XEEs) to investigate the mitotic roles and regulation of p31<sup>comet</sup>. Our observations suggest that endogenous p31<sup>comet</sup> is important for anaphase timing in this system and is regulated through mitotic phosphorylation. While several well established mitotic kinases did not efficiently modify p31<sup>comet</sup> *in vitro*, IKK-beta (Inhibitor of nuclear factor k-B kinase-beta) was an effective p31<sup>comet</sup> kinase. Depletion or inhibition of IKK-beta delayed mitotic exit of XEEs, and a phosphomimetic p31<sup>comet</sup> mutant showed increased activity in SAC silencing. Together, our experiments suggest that p31<sup>comet</sup> contributes to the timing of anaphase onset in XEE through antagonism of the SAC and that IKK-beta modifies p31<sup>comet</sup> to enhance its activity. Several previous reports established that IKK-beta plays a clear but under-appreciated role of within mitosis, a role that is distinct from its function in cellular stress and inflammatory signaling pathways. Our findings are among the first mechanistic insights into the nature of this role (Reference 1).

## Development of novel assays for the quantitative assessment of chromosome instability

Most solid tumors are aneuploid, that is, they carry an abnormal number of chromosomes, and they missegregate whole chromosomes in a phenomenon termed chromosome instability (CIN). CIN is associated with poor prognosis in many cancer types, and targeting of CIN is an attractive strategy for anti-cancer therapeutics. The mechanisms causing CIN and its contributions to tumor initiation and growth are not well defined, partly because there is no straightforward, quantitative assays for CIN in human cells. To address this problem, we developed the first Human Artificial Chromosome (HAC)-based quantitative live-cell assay for mitotic chromosome segregation in mammalian cells, with which we can easily score the rates of CIN within one cell division under different experimental conditions (Reference 3). We constructed a HAC encoding copies of enhanced green fluorescent protein (eGFP) fused to the destruction box (DB) of hSecurin, a substrate of the anaphase-promoting complex/cyclosome (APC/C) ubiquitin ligase, which becomes active during anaphase to catalyze the proteolysis of critical mitotic target proteins. This HAC also contains tetracycline operator (tetO) arrays and sequences encoding the tetracycline repressor fused to monomeric cherry fluorescent protein (tetR-mCherry). We produced human U2OS cells (U2OS-Phoenix) carrying this HAC, in which we monitor HAC segregation in two ways. First, APC/C degrades the DB-eGFP fusion expressed from the HAC at anaphase onset, and DB-eGFP re-accumulates in the daughter cells after G1 phase, when APC/C becomes inactive. Daughter cells that do not obtain a copy of the HAC will thus be GFP-negative in the subsequent interphase (Figure 4). Second, because tetR-mCherry binds to the tetO arrays, the HAC itself could be followed by live imaging. Following the HAC by live-cell imaging experiments, we showed that U2OS-Phoenix cells have low inherent levels of CIN, but that HAC mis-segregation is markedly increased by treatment with Reversine, an inhibitor of the mitotic monopolar spindle 1 kinase (Mps1), and the microtubule agents Nocodazole and Taxol. In summary, we developed new assays to score CIN levels in human cells and showed that CIN levels increase upon chemical disruption of mitotic progression, demonstrating the utility of this assay for chemical screens of CIN-inducing compounds. The development

of additional assays for CIN is ongoing, as are efforts to use the assays in high-throughput screens for genes and chemical compounds that can modulate CIN frequency.

## Analysis of IRBIT function in *Drosophila*

We discovered that the vertebrate IRBIT protein inhibits the catalytic activity of ribonucleotide reductase (RNR), the enzyme that catalyzes the production of deoxynucleotides for DNA synthesis. Similar biochemical relationships are conserved between mammalian and *Drosophila melanogaster* homologs of both proteins, allowing us to employ flies as a genetic system to analyze IRBIT biology. We generated flies lacking *Drosophila* IRBIT (*dIRBIT*<sup>-/-</sup> flies), which superficially appeared normal and were viable but sickly. In collaboration with the laboratories of Mihaela Serpe and Brian Oliver, we are particularly analyzing the role of IRBIT in tissue homeostasis within the fly midgut.

## Additional Funding

- NICHD DIR Director's Investigator Award

## Publications

1. Mo M, Arnaoutov A, Dasso M. Phosphorylation of Xenopus p31comet potentiates mitotic checkpoint exit. *Cell Cycle* 2015 14:3978-3985.
2. Ryu H, Yoshida MM, Sridharan V, Kumagai A, Dunphy WG, Dasso M, Azuma Y. SUMOylation of the C-terminal domain of DNA topoisomerase IIa regulates the centromeric localization of Claspin. *Cell Cycle* 2015 14:2777-2784.
3. Markossian S, Arnaoutov A, Saba NS, Larionov V, Dasso M. Quantitative assessment of chromosome instability induced through chemical disruption of mitotic progression. *Cell Cycle* 2016 15:1706-1714.
4. Dasso M, Fontoura BM. Gating immunity and death at the nuclear pore complex. *Cell* 2016 166:1364-1366.
5. Dasso M. Kar9 controls the cytoplasm by visiting the nucleus. *Dev Cell* 2016 36:360-361.

## Collaborators

- Yoshiaki Azuma, PhD, *University of Kansas, Lawrence, KS*
- Vladimir Larionov, PhD, *Developmental Therapeutics Branch, Center for Cancer Research, NCI, Bethesda, MD*
- Brian C. Oliver, PhD, *Laboratory of Cellular and Developmental Biology, NIDDK, Bethesda, MD*
- Mihaela Serpe, PhD, *Unit on Cellular Communication, NICHD, Bethesda, MD*

## Contact

For more information, email [mdasso@helix.nih.gov](mailto:mdasso@helix.nih.gov) or visit <http://sccr.nichd.nih.gov>.

## Molecular Genetics of Embryogenesis in Zebrafish and *Xenopus*

The laboratory uses the frog *Xenopus laevis* and the zebrafish *Danio rerio* as experimental systems in which to study molecular-genetic mechanisms of early vertebrate development. Recently, we focused on the mechanisms and role of protein stability in regulating early pancreas development and on the function of the BTB domain-containing protein Kctd15 in development. The BTB domain is a protein-protein interaction domain that is part of many proteins. Understanding its function in many contexts will help elucidate the mechanisms of protein interactions.

### The BTB-domain protein Kctd15 is an inhibitor of neural crest formation and of the transcription factor AP-2.

Our laboratory has a long-standing interest in the formation of the neural crest (NC), a group of cells with stem-cell properties that arise at the dorsal neural tube and migrate to many locations in the embryo to give rise to a large number of varied differentiated derivatives. A recent focus has been the role of the BTB domain-containing protein Kctd15, which is capable of inhibiting NC formation. In pursuing the molecular mechanism of Kctd15 action, we found that Kctd15 regulates the activity of the transcription factor AP-2. AP-2 is known to play a key role in the induction and differentiation of NC cells. We found that AP-2 and Kctd15 can interact when co-expressed in cultured cells. Further, Kctd15 is a highly effective inhibitor of AP-2 activity in a reporter assay (Figure 1). In studying the mechanism of inhibition of AP-2 by Kctd15, we found that Kctd15 interacts with the activation domain of AP-2. We further analyzed this system using a fusion product between the Gal4 DNA-binding domain and the AP-2-activation domain. Within the latter domain, a conserved proline-rich motif proved critical for Kctd15 interaction: mutation of proline 59 to alanine (P59A) in the Gal4-AP-2 fusion resulted in a protein that was active but could not bind and was insensitive to inhibition by Kctd15 (Figure 2). The proline residue was also essential for Kctd15 sensitivity in the context of the full-length AP-2 molecule. Thus, we conclude that Kctd15 inhibits AP-2 by binding to a specific site in its activation domain (Reference 1).

Recently, we tested for Kctd15 function by overexpressing this protein

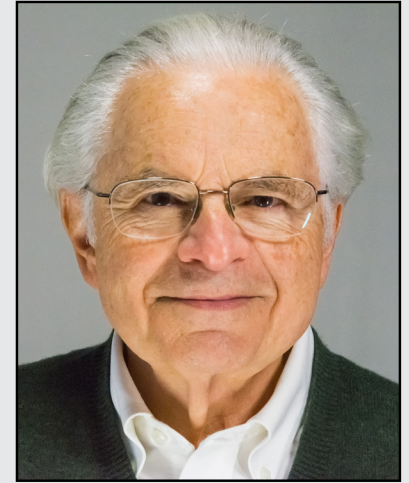

**Igor B. Dawid, PhD**, *Head, Section on Developmental Biology*

Alison M. Heffer, PhD, *Intramural Research Training Award Fellow*

Allisan Aquilina-Beck, MS, *Fish Technician*

Nabil Saleem, BS, *Pre-Intramural Research Training Award Fellow*

in animal explants (animal caps) from *Xenopus* embryos, followed by microarray analysis of the transcriptome of control and overexpressing explants. We confirmed that Kctd15 inhibits several markers of the neural crest, and we reported on additional genes affected by overexpression of this factor (Reference 5).

In addition, we generated frameshift mutations in both Kctd15 paralogs in zebrafish, using TALENs restriction enzymes for gene editing. Mutants in both Kctd15a and Kctd15b are viable and fertile but show slow growth and several additional phenotypes, which are currently under study.

## Lnx2 ubiquitin ligase is essential for exocrine cell differentiation in the early zebrafish pancreas.

Pancreas development is of great interest as a prime example of organogenesis and because of the importance of understanding the development of insulin-producing cells and regulation of insulin synthesis. We found that the E3 ubiquitin ligases Lnx2a and Lnx2b play an important role in early pancreas differentiation in the zebrafish. While mammals have only one *Lnx2* gene, zebrafish have two closely related paralogs, *Lnx2a* and *Lnx2b*. In studying the gene that encodes Lnx2a, we found that it is expressed in the ventral pancreatic bud, in addition to being expressed in the nervous system (Figure 3). In the early zebrafish embryo, the ventral bud gives rise to exocrine cells and the dorsal bud to the primary islet, which contains endocrine cells. In later development, ventral bud progenitors give rise to secondary islets and duct cells in addition to exocrine cells. We found that a splice morpholino (MO) that blocks *Lnx2a* exon2/3 splicing inhibits exocrine marker expression while leaving endocrine marker expression unaffected (Figure 4). To test MO

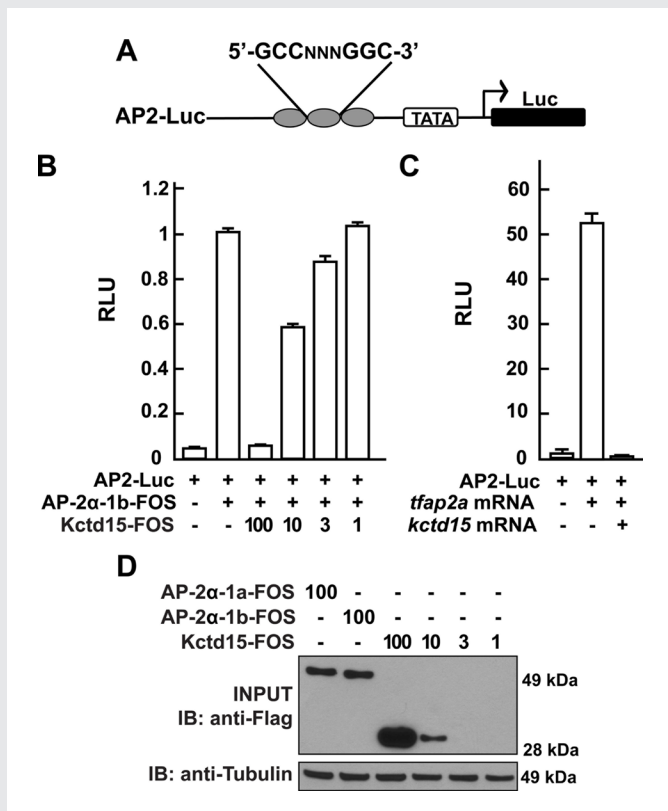

**FIGURE 1. Kctd15 represses AP-2 function.**

A. AP2-Luc reporter, containing three AP-2 consensus sites driving expression of luciferase (Luc).

B. The reporter was strongly stimulated by zebrafish AP-2α and dramatically inhibited by zebrafish Kctd15 (levels indicated in ng). RLU, relative light units.

C. Reporter activity in zebrafish embryos.

D. Cells were transfected with FOS-tagged zebrafish AP-2α and Kctd15, and lysates were blotted to assay expression of both proteins. From Zarelli and Dawid, 2013 (Reference 1).

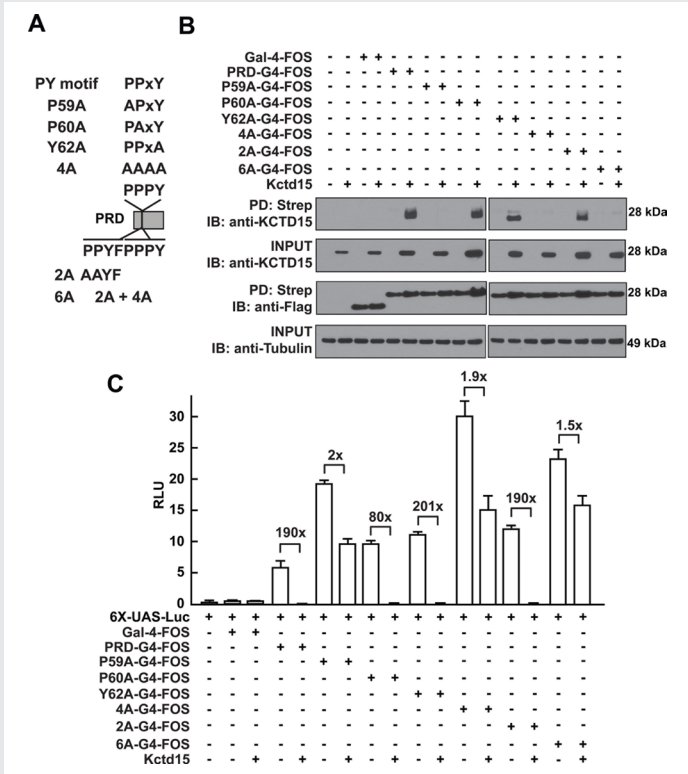

**FIGURE 2. Critical role of P59 for Kctd15 interaction and inhibition of AP-2**

A. Mutants in the conserved PPxY motif within the AP-2 $\alpha$  proline-rich domain (PRD) and two additional mutants in the adjoining region are shown. PRDs were fused to the Gal4-DNA-binding domain and the FOS tag.

B. Kctd15 interaction depends on proline 59 (P59). WT and mutant fusion constructs were expressed in HEK293T cells alone or with Kctd15, and complexes were pulled down using a Strep-Tactin matrix. PRDs could bind to Kctd15 except in the constructs containing the P59A mutation (P59A, 4A and 6A). The constructs were expressed at similar levels.

C. PPxY mutants activate the UAS-Luc reporter two-to-five fold more highly than does WT PRD-Gal4. PRD-Gal4 WT and P60A, Y62A (tyrosine 62 to alanine), and 2A were dramatically inhibited by zebrafish Kctd15, whereas P59A and mutants containing this change were inhibited two-fold or less. Figure from Zarelli and Dawid, 2013 (Reference 1).

specificity, we used TALEN-mediated gene targeting to generate a frame-shift mutation, *Inx2a*<sup>delta70</sup>, that does not produce Lnx2a protein. The mutant fish proved to be phenotypically wild type (WT), with normal exocrine gene expression (Figure 5A-E). Further analysis showed that the splice MO led to exon skipping, generating an mRNA that produces a protein shorter than the WT (Figure 5F-H). Mass spectrometry showed the protein to be an N-truncated version of the WT protein that had lost the catalytically active RING domain. We wondered whether the truncated protein could act as an interfering factor and found this to

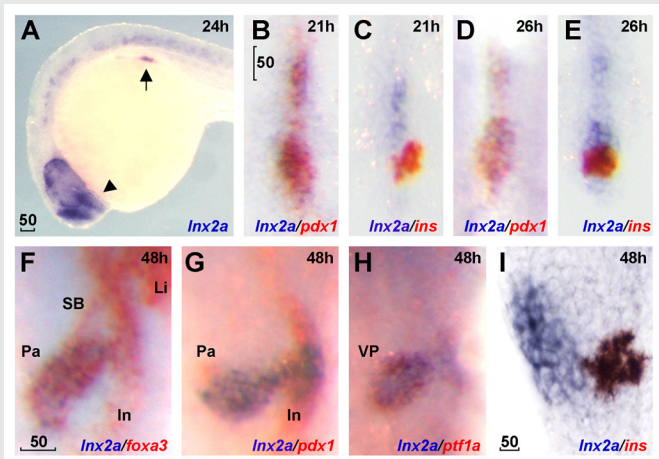

**FIGURE 3. *Inx2a* is expressed in the ventral pancreas during early pancreas specification.**

Lateral views (A and I), dorsal views (B-E), and ventral views (F-H). A. *Inx2a* transcripts (*blue*) are detected in regions of the endoderm (*arrow*), forebrain (*arrowhead*) and the spinal cord at 24 hours post fertilization (hpf). Expression of *pdx1* (B, D, and G), *ins* (C, E, and I) and *foxa3* (F) are in red. *Inx2a* expression is observed in the antero-ventral part of *pdx1*-positive pancreas precursors at 21 (B) and 26 (D) hpf, but excluded from  $\beta$ -cells (*ins*<sup>+</sup>) in the dorsal pancreas at 21 (C), 26 (E), and 48 (I) hpf. At 48 hpf, *Inx2a* expression is detected in the ventral pancreas but not in the intestine, swim bladder, or liver (F-H). Li, liver; In, intestine; Pa, pancreas; SB, swim bladder; VP, ventral pancreas; scale bar, 50 $\mu$ m.

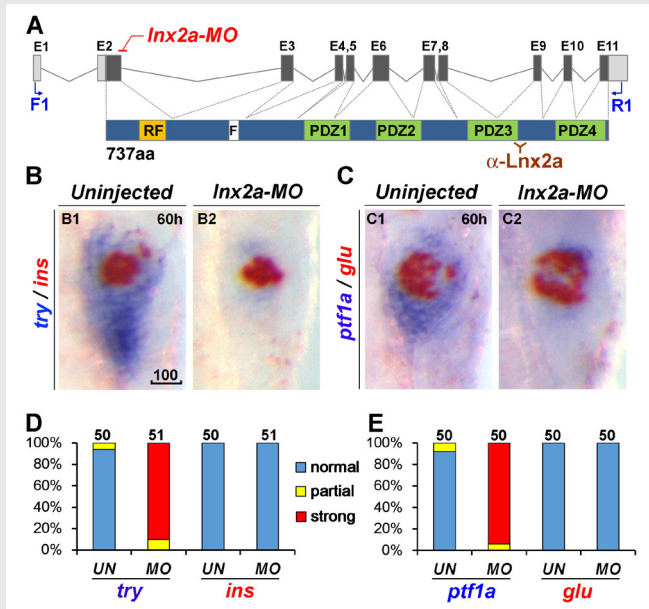

FIGURE 4. *Inx2a* knock-down causes defects in the exocrine pancreas.

A. Schematic drawing of the *Inx2a* locus containing 11 exons and the Lnx2a protein (737 aa) containing a RING-finger domain (RF), the Numb-binding NPAF motif (F), and four PDZ domains. The translation initiation site is located in exon 2. The *Inx2a*-MO targets the splice donor site of exon 2. Primers in exon 1 (F1) and exon 11 (R1) are shown, as is the epitope for the Lnx2a antibody. B and C. The *Inx2a*-MO leads to inhibition of exocrine markers (*try*, *ptf1a*), but not endocrine markers (*ins*, *glu*) at 60 hpf. D and E. Quantification of marker expression. UN, uninjected; MO, *Inx2a*-MO; scale bar, 100  $\mu$ m.

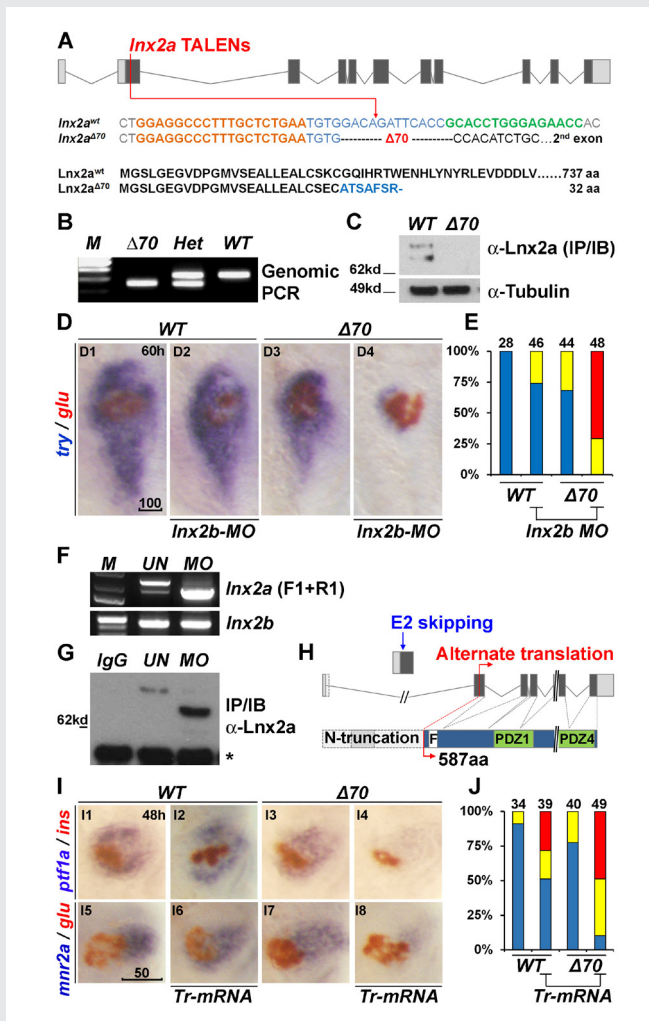

FIGURE 5. Generation of *Inx2a*<sup>Δ70</sup> mutant using TALENs, and the functional redundancy of *Inx2* genes

A. Schematic representation of the *Inx2a* locus and the TALEN target site in exon 2. TALEN targets (*left*, *orange* and *right*, *green*), and the *Inx2a*<sup>Δ70</sup> mutation are shown. Next, the protein sequences of wild-type and the *Inx2a*<sup>Δ70</sup> frameshift allele are shown. Genotype of the *Inx2a*<sup>Δ70</sup> mutant was analyzed by genomic PCR (B) and immuno-blotting of Lnx2a protein (C). D. Marker gene (*try* and *glu*) expression shows little effect in *Inx2a*<sup>Δ70</sup>-null mutants or in *Inx2b*-MO-injected embryos. However, *Inx2b*-MO injection into *Inx2a*<sup>Δ70</sup>-mutant embryos shows suppression of exocrine markers. E. Quantification of defects. F-H. *Inx2a*-MO leads to production of N-truncated Lnx2a protein. F. RT-PCR using primers F1 and R1 (Figure 4A) followed by sequencing shows that *Inx2a*-MO injection results in exon 2 skipping; *Inx2b* expression was unchanged. G. Endogenous Lnx2a showed a smaller protein in *Inx2a*-MO-injected embryos. H. Schematic drawing of exon 2 skipping, alternate translation start site, and N-truncated protein in *Inx2a*-MO-injected embryos. I. N-truncated Lnx2a has an interfering effect; *Tr*-mRNA was injected into the WT and *Inx2a*<sup>Δ70</sup>-mutant embryos. J. Quantification of pancreatic defects in (I). Scale bars: 100  $\mu$ m (D1) and 50  $\mu$ m (I5).

be the case, as injection of RNA encoding the truncated protein into *Inx2a*<sup>delta70</sup> embryos reproduced the exocrine deficiency phenotype (Figure 5I and J). The effect is the result of inhibition of Lnx2b function by the truncated Lnx2a, as indicated by the fact that injection of *Inx2b*-MO into *Inx2a*<sup>delta70</sup> reproduced the exocrine deficiency phenotype (Figure 5D and E). Definitive genetic evidence for our interpretation of the mechanism of the *Inx2a*-splice MO phenotype came from a mutation, *Inx2a*<sup>delta329</sup>, that deletes the exon/intron boundary targeted by the splice MO. *Inx2a*<sup>delta329</sup>-mutant fish effectively reproduce the exocrine deficiency phenotype seen originally in *Inx2a*-splice MO-injected embryos (Figure 6).

The most widely studied role of the ubiquitin pathway and E3 ubiquitin ligases is in the regulation of protein turnover. Numb is known as a target of mammalian Lnx proteins, and we confirmed that zebrafish Lnx2a can mediate the ubiquitination and degradation of Numb. Numb is a known inhibitor of the Notch signaling pathway, and Notch is an important factor in early pancreas formation. We thus hypothesized that depletion of Lnx2a and Lnx2b leads to stabilization of Numb when it normally should be turned over, resulting in inhibition of Notch and thereby in a defect in pancreas cell differentiation. This view is strongly supported by the fact that a Numb-MO can rescue the loss of endocrine marker expression in *Inx2a*-splice MO-injected embryos and in *Inx2a*<sup>delta329</sup>-mutant fish (Figure 7).

Previous work by several laboratories may be summarized in our context as follows: (1) Notch signaling is required in pancreatic cell differentiation; (2) high Notch activity maintains precursor pools, while lower activity allows differentiation, in certain cases preceded by proliferation; (3) cells that downregulate Notch cannot maintain their precursor status. Our results led us to the following model for the role of Lnx2 proteins in pancreas development in zebrafish. We suggest that Lnx2a, together with Lnx2b, destabilizes Numb in ventral bud-derived cells, allowing Notch activity, which may be required for the specification and expansion of precursor cells. Loss of Lnx2 activity in the *Inx2a*<sup>delta329</sup> mutant or *Inx2a* morphant

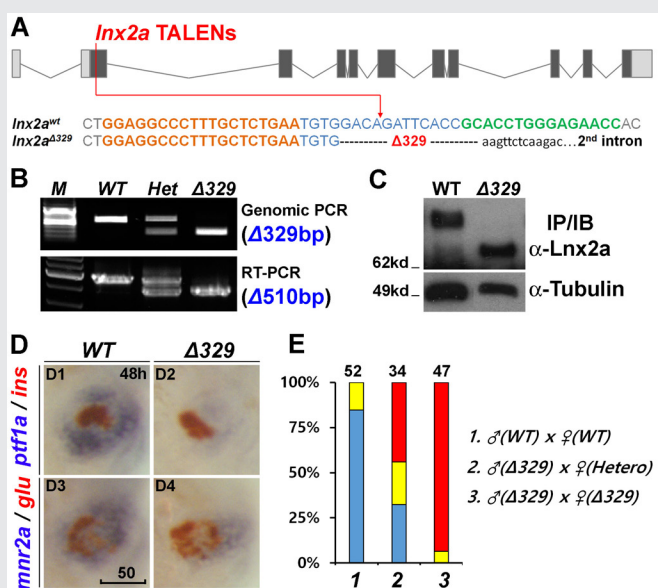

**FIGURE 6.** The *Inx2a*<sup>Δ329</sup> mutant recapitulates the morphant phenotype.

A. Sequence of the *Inx2a*<sup>Δ329</sup> mutation. The mutant has lost the exon 2 splice donor site.  
 B and C. Genotyping of *Inx2a*<sup>Δ329</sup> by genomic PCR (Δ329), RT-PCR (Δ510 equaling exon 2) (B), and by Western blotting showing N-truncated protein (C).  
 D. Phenotypic analysis of *Inx2a*<sup>Δ329</sup> mutants at 48 hpf.  
 E. Quantification of D. Scale bar, 50mm.

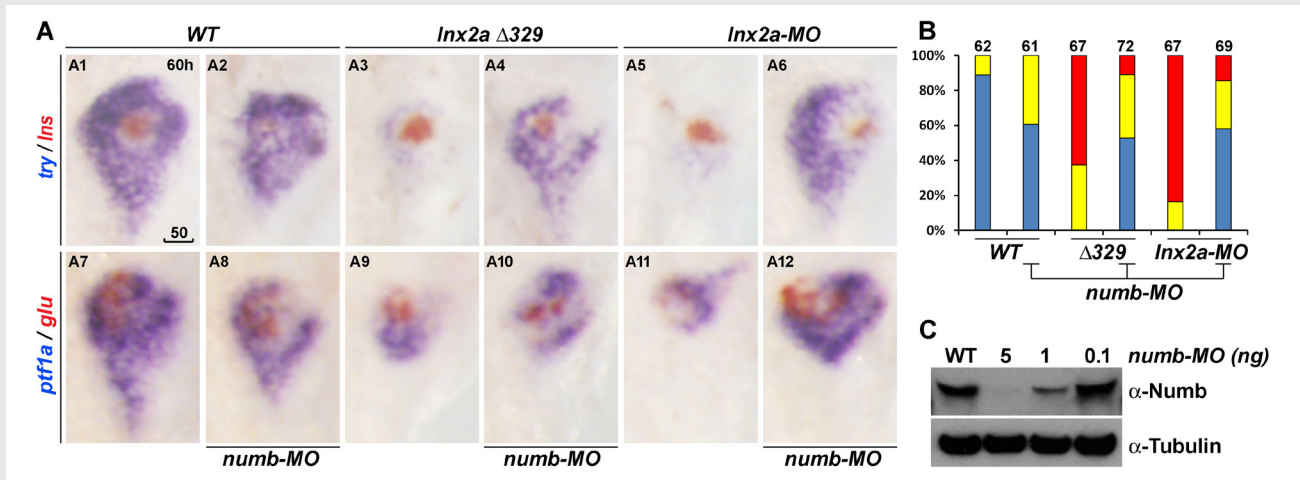

FIGURE 6. Ventral pancreas defects in *Inx2a* <sup>$\Delta 329$</sup> -mutant and *Inx2a*-MO-injected embryos can be rescued by knock-down of Numb.

A. The translation-blocking MO for Numb was injected into WT, *Inx2a* <sup>$\Delta 329$</sup> -mutant and *Inx2a*-MO-injected embryos, and pancreatic phenotype was examined at 60 hpf.

B. Quantification of pancreatic defects by analysis of *ptf1a* expression. Exocrine pancreas defects were substantially rescued by knock-down of Numb; *numb*-MO had little effect in WT embryos.

C. Immuno-blotting of embryo extracts with Numb antibody shows the efficiency of the *numb*-MO. Scale bar, 50  $\mu$ m.

stabilizes Numb to inhibit Notch in cells where it is normally active, ultimately interfering with the normal developmental progression of these cells. We suggest that, in normal development, the regulation of Numb protein stability by *Lnx2a/b* is an important component of the system that controls the levels of Notch activity during pancreas formation and the assignment of cells to different pancreatic lineages (Reference 4).

## Publications

- Zarelli VE, Dawid IB. Inhibition of neural crest formation by Kctd15 involves regulation of transcription factor AP-2. *Proc Natl Acad Sci USA* 2013 110:2870-2875.
- Toyama R, Kim MH, Rebbert ML, Gonzales J, Burgess H, Dawid IB. Habenular commissure formation in zebrafish is regulated by the pineal gland-specific gene *unc119c*. *Dev Dyn* 2013 242:1033-1042.
- Kim MH, Rebbert ML, Ro H, Won M, Dawid IB. Cell adhesion in zebrafish embryos is modulated by March 8. *PLoS One* 2014 9:e94873.
- Won M, Ro H, Dawid IB. *Lnx2* ubiquitin ligase is essential for exocrine cell differentiation in the early zebrafish pancreas. *Proc Natl Acad Sci USA* 2015 112(40):12426-12431.
- Wong TC, Rebbert M, Wang C, Chen X, Heffer A, Zarelli VE, Dawid IB, Zhao H. Genes regulated by potassium channel tetramerization domain containing 15 (Kctd15) in the developing neural crest. *Int J Dev Biol* 2016 60:159-166.

## Collaborators

- Harold Burgess, PhD, Section on Behavioral Neurogenetics, NICHD, Bethesda, MD



- Raymond Habas, PhD, *Temple University, Philadelphia, PA*
- Hui Zhao, PhD, *The Chinese University, Hong Kong, China*

## Contact

For more information, email [dawidi@mail.nih.gov](mailto:dawidi@mail.nih.gov) or visit <http://sdb.nichd.nih.gov>.

## Regulation of Pubertal Onset and Reproductive Development

We are interested in identifying the initiating factors for pubertal onset in children. Our long-term goal is to define the developmental physiology of pubertal development, in order to gain a better understanding of human disorders of puberty and reproduction. In collaboration with the Reproductive Endocrine Unit (REU) at the Massachusetts General Hospital (MGH), the Reproductive Physiology and Pathophysiology (RPP) Group at the National Institute of Environmental Health Sciences (NIEHS), and an ever growing network of international collaborations, we are conducting translational research on the neuroendocrine and genetic control of gonadotropin-releasing hormone (GnRH) secretion and its regulation of gonadotropin secretion and gonadal physiology. We use molecular and biochemical techniques, as well as comprehensive clinical phenotyping of human subjects to identify and characterize biological pathways that may contribute to the reactivation of GnRH secretion at puberty, and to explore diagnostic techniques for, treatment of, and the long-term consequences of disorders of puberty and reproduction.

### Role of gonadotropin pulsations in the regulation of puberty and fertility

At one extreme of pubertal development, deficiency of GnRH results in a spectrum of rare clinical disorders of isolated GnRH deficiency (IGD), also known as idiopathic hypogonadotropic hypogonadism (IHH), which presents with delayed, incomplete, or absent sexual maturation. Defining the physiology of GnRH secretion is critical to understanding the clinical heterogeneity of IGD, particularly in light of emerging gene discoveries that aim to elucidate genotype-phenotype correlations. Non-reproductive phenotypic features have been identified in some individuals, including anosmia, auditory defects, and skeletal, neurological, and renal anomalies. These additional features may be the key to determining the developmental function of genes implicated in this spectrum of disorders.

Our clinical protocol (<http://gp.nichd.nih.gov>), which is a multicenter study in collaboration with the REU at MGH, identified a broad range of luteinizing hormone (LH) pulsatility patterns and other features, which are being investigated in the context of genetic variants, where identified, in order to increase our understanding of the ontogeny of



**Angela Delaney, MD**, *Head, Unit on Genetics of Puberty and Reproduction*

Rebecca Hicks, BA,  
*Postbaccalaureate Intramural Research Training Award Fellow*

Alessandro Albano, BS,  
*Postbaccalaureate Intramural Research Training Award Fellow*

Kyle R. Brunner, *Special Volunteer*

these disorders. Our phenotyping efforts found that uterine anomalies and Chiari type 1 malformations may represent novel, non-reproductive features of IGD, which is now being investigated in our genetic study (below) to determine whether there is a common molecular cause for these phenotypes. We also initiated a pilot study to determine the prevalence of psychiatric disorders and symptoms of negative emotional states in our cohort, compared with healthy controls, in order to determine whether there are previously unidentified psychological features in need of further investigation.

As a result of the phenotyping efforts pioneered by our collaborators at MGH, several rare phenotypic categories have been described in men with IGD, including adult-onset IHH (Nachtigall LB *et al. N Engl J Med* 1997;336:410) and reversal of the disorder after a period of treatment (Raivio T *et al. N Engl J Med* 2007;357:863). We recently reported that subjects with confirmed reversal, or recovery from HH with sustained endogenous LH pulsatility, are responsive to IV bolus infusions of kisspeptin, a neuropeptide known to be a key stimulus of GnRH release in the human. On the other hand, subjects who relapse from their recovery are not responsive to kisspeptin, whereas they do respond to GnRH, suggesting that pituitary responsiveness is intact. Thus, the acquisition and maintenance of kisspeptin responsiveness may play a role in reversal and, by extension, in pubertal development (Reference 1).

## Neurocognitive effects of sex hormone deficiency at or before puberty

There is little existing evidence for the neurocognitive effects of delayed puberty. We performed neurocognitive testing and structural and functional MRI on subjects with IGD and compared them with healthy controls matched for age, sex, and race. Accounting for gender, our preliminary findings suggested that, in both sexes, pubertal sex steroid deficiency contributes to persistent structural and functional brain differences as well as to neurocognitive deficits primarily involving spatial ability and recognition memory, thus providing direct evidence in humans for the critical spatiotemporal role played by appropriately timed pubertal sex steroids during normal brain development. The final analysis of these data is being completed, with a manuscript in preparation.

## Molecular basis of inherited reproductive disorders

Human and animal models have identified several genes responsible for IGD, but more than half the patients with clinical evidence of the disorder do not have a detectable mutation. In addition, there is significant clinical heterogeneity among affected individuals, including members of the same family harboring the same mutations, which is often explained by oligo-digenic inheritance patterns. The Molecular Genomics Core (NICHD) performed exome sequencing (ES) on 28 probands participating in our genetic research protocol (<http://ird.nichd.nih.gov>), including several extended families, to identify novel genes responsible for IGD. Data analysis is under way, and our findings are likely to yield important insights into additional pathways involved in the regulation of GnRH secretion. In one of our larger families, we identified a novel candidate gene for Kallmann syndrome (KS), which is characterized by IHH and anosmia. All affected individuals in this family carry a heterozygous nonsense variant in a gene whose function has been indirectly associated in animal models with the neuronal migration defect affecting GnRH neurons and which is responsible for the KS phenotype. Functional validation of the role of this gene in IGD is planned.

In addition, through our collaboration with the REU at MGH, we also performed ES in several families with IGD and known uterine anomalies, and we have enrolled a cohort of individuals with delayed pubertal development and Chiari type 1 malformations, whose genomic DNA will soon be sent for ES, based on

discoveries made through our phenotyping protocol. Analysis of these data has the potential to identify new non-reproductive features of IGD, as well as novel molecular pathways involved in the regulation of GnRH secretion and uterine or brain/skull development.

We are also investigating the role of genetic variants in 14 genes known to cause IGD in a subgroup of individuals with functional hypothalamic amenorrhea (HA), a hormonally similar condition that occurs in association with risk factors such as nutritional deprivation, exercise, or significant stress. We aim to determine whether variants in the IGD genes are over-represented in individuals with HA compared with the general population. If the data support our hypothesis, we would have further evidence that heterozygous variants in these genes may confer an increased susceptibility to developing HA in the setting of physiologic stressors, such as nutritional deficiency, extreme exercise, or psychological stress.

At the other extreme of pubertal development are patients with premature reactivation of hypothalamic GnRH secretion, resulting in idiopathic central precocious puberty (CPP). There is evidence that familial cases account for anywhere from 20–45% of CPP, with most studies describing autosomal dominant inheritance patterns. Far less is known about the molecular basis of CPP, and candidate gene approaches have not been successful in identifying the molecular basis of this disorder. Thus, an unbiased approach to gene discovery seems more likely to achieve the goal of identifying novel candidate genes responsible for premature GnRH secretion in CPP, as was recently shown with the identification of causative mutations in *MKRN3*, using ES (Abreu AP *et al.* *N Engl J Med* 2013; 368:2467). We have established collaborations with investigators both locally and internationally to increase recruitment of families with idiopathic CPP, and we are planning to perform ES analysis on this cohort in the coming months.

Examining the genetic characteristics of subjects with pubertal disorders will reveal insights into the mechanisms underlying the reawakening of the hypothalamic-pituitary-gonadal axis at puberty and will provide opportunities for new diagnostic capabilities and therapeutic interventions for disorders of puberty and reproduction.

## Blockade of kisspeptin signaling in women

The neuropeptide hormone kisspeptin potently stimulates secretion of GnRH. While single doses of kisspeptin stimulate the reproductive endocrine axis, animal models suggest that, paradoxically, continuous administration of kisspeptin suppresses the reproductive endocrine axis temporarily through desensitization of the kisspeptin receptor. By administering 24-hour infusions of kisspeptin to healthy women and to patients with reproductive disorders, we hope to learn more about the role of kisspeptin both in normal physiology and in pathological conditions, such as polycystic ovary syndrome (PCOS), a common condition characterized by ovulatory dysfunction and hyperandrogenism. Among other disturbances of hormonal regulation, patients with PCOS have high-amplitude, high-frequency LH pulses, which may contribute to the oligo-anovulation characteristic of this disorder.

In collaboration with Stephanie Seminara, and previously funded through an NIH Bedside-to-Bench Award, we investigated healthy postmenopausal women to determine the safety of continuous kisspeptin administration in women and the proper dose and conditions required to achieve desensitization of the kisspeptin receptor. Once these conditions had been established, we planned to administer the peptide to women with PCOS to determine whether abnormal kisspeptin signaling is involved in these disturbed

endocrine dynamics, as greater understanding of how kisspeptin modulates GnRH secretion in this condition could lead to novel therapeutic interventions for this patient population. Unfortunately, as a result of insurmountable drug availability issues, this study was recently terminated.

## Additional Funding

- NICHD DIR Molecular Genomics Lab Sequencing Award, 2014: Novel Gene Discovery in Inherited Reproductive Disorders (ongoing)
- NICHD DIR Molecular Genomics Lab Sequencing Award, 2015: Novel Gene Discovery in Inherited Reproductive Disorders (ongoing)
- NICHD DIR Molecular Genomics Lab Sequencing Award, 2016: Novel Gene Discovery in Inherited Reproductive Disorders (ongoing)

## Publications

1. Lippincott MF, Chan YM, Delaney A, Rivera-Morales D, Butler JP, Seminara SB. Kisspeptin responsiveness signals emergence of reproductive endocrine activity: implications for human puberty. *J Clin Endocrinol Metab* 2016 101(8):3061-3069.

## Collaborators

- Ravikumar Balasubramanian, MBBS, *Massachusetts General Hospital, Boston, MA*
- Jeffrey Baron, MD, *Section on Growth and Development, NICHD, Bethesda, MD*
- Jonathan Blumenthal, MA, *Child Psychiatry Branch, NIMH, Bethesda, MD*
- Raja Brauner, MD, *Université Paris Descartes and Fondation Ophtalmologique Adolphe de Rothschild, Paris, France*
- Yee-Ming Chan, MD, PhD, *Massachusetts General Hospital, Boston, MA*
- William F. Crowley Jr, MD, *Massachusetts General Hospital, Boston, MA*
- Jay N. Giedd, MD, *Child Psychiatry Branch, NIMH, Bethesda, MD*
- Janet E. Hall, MD, *Massachusetts General Hospital, Boston, MA, and Clinical Research Unit, NIEHS, Research Triangle Park, NC*
- James R. Iben, PhD, *Molecular Genomics Core, NICHD, Bethesda, MD*
- Youn Hee Jee, MD, *Section on Growth and Development, NICHD, Bethesda, MD*
- Francois Lalonde, PhD, *Child Psychiatry Branch, NIMH, Bethesda, MD*
- Margaret F. Lippincott, MD, *Massachusetts General Hospital, Boston, MA*
- Kenneth McElreavey, PhD, *Institut Pasteur, Paris, France*
- Veronica Mericq, MD, *University of Chile, Santiago, Chile*
- Paulina Merino, MD, *University of Chile, Santiago, Chile*
- Lacey Plummer, MS, *Massachusetts General Hospital, Boston, MA*
- Richard Quinton, MB BChir, MD, FRCP, *Newcastle University, Newcastle-upon-Tyne, United Kingdom*
- Stephanie B. Seminara, MD, *Massachusetts General Hospital, Boston, MA*
- Natalie D. Shaw, MD, MMSc, *Massachusetts General Hospital, Boston, MA*

## Contact

For more information, email [delaney@mail.nih.gov](mailto:delaney@mail.nih.gov).

## Regulation of Mammalian Cell Proliferation and Differentiation

Nothing is more fundamental to living organisms than the ability to reproduce. Each time a human cell divides, it must duplicate its genome, a problem of biblical proportions. A single fertilized human egg contains 2.1 meters of DNA. An adult of about 75 kg (165 lb) consists of about 29 trillion cells containing a total of about 60 trillion meters of DNA, a distance equal to 400 times the distance from Earth to sun. Not only must the genome be duplicated trillions of times during human development, but it must be duplicated once and only once each time a cell divides (termed mitotic cell cycles). If we interfere with this process by artificially inducing cells to re-replicate their nuclear genome before cell division, the result is DNA damage, mitotic catastrophe, and programmed cell death (apoptosis). On rare occasions, specialized cells can duplicate their genome several times without undergoing cell division (termed endocycles), but when this occurs, it generally results in terminally differentiated polyploid cells, which are viable but no longer proliferate. As we age, however, the ability to regulate genome duplication diminishes, resulting in genome instability, which allows genetic alterations that can result in promiscuous cell division—better known as cancer. For a comprehensive description of genome duplication in all forms of life, refer to DePamphillis ML, Bell SD. *Genome Duplication*, Garland Science, 2010; DNA Replication. Eds. Mechali M, DePamphillis ML. *Cold Spring Harb Perspect Biol* 2013).

Our research program focuses on three questions. What are the mechanisms that restrict genome duplication to once per cell division? How are these mechanisms circumvented to allow developmentally programmed induction of polyploidy in terminally differentiated cells? How can we manipulate these mechanisms to destroy cancer cells selectively?

### Regulation of DNA replication in mammalian cells

Genome duplication begins when the six-subunit origin recognition complex (ORC) binds to specific chromosomal loci termed origins of bidirectional replication, which we and others have mapped at specific sites in the genomes of flies and mammals. The sites are determined by both genetic and epigenetic features. The number



**Melvin L. DePamphillis, PhD,**  
*Head, Section on Eukaryotic Gene Regulation*

Kotaro Kaneko, PhD, *Staff Scientist*

Alex Vassilev, PhD, *Staff Scientist*

Diane Adler-Wailes, MS, *Senior Research Assistant*

Xiaohong Zhang, BA, *Technical Assistant*

Yi-Yuan Huang, PhD, *Visiting Fellow*

Courtney Kurtyka, PhD, *Postdoctoral Fellow*

Gaurav Sharma, PhD, *Visiting Fellow*

**FIGURE 1. The ORC cycle in mammalian cells** (see Noguchi *et al. EMBO J* 2006;25:5372 and references therein)

ORC(1–6) is bound to chromatin during the G1 phase of the cell cycle, at which time it is part of a prereplication complex. When S phase begins, the association between Orc1 and chromatin-bound ORC(2–6) is destabilized by selective CDK-dependent phosphorylation and ubiquitination. Monoubiquitinated Orc1 is exported to the cytoplasm. The remaining ORC subunits are subsequently released from chromatin. Polyubiquitinated Orc1 is degraded by the 26S proteasome. Orc1 levels are restored during the G2-to-M transition, but Orc1 is hyperphosphorylated, an event that prevents ORC assembly. During the anaphase-to-G1 phase transition, Orc1 is dephosphorylated and, together with other ORC subunits, binds to chromatin, an event facilitated by the Orc1 BAH domain, a protein/protein interaction domain involved in gene silencing. If Orc1 is not associated with other ORC subunits, or if it is not phosphorylated or ubiquitinated, it induces apoptosis.

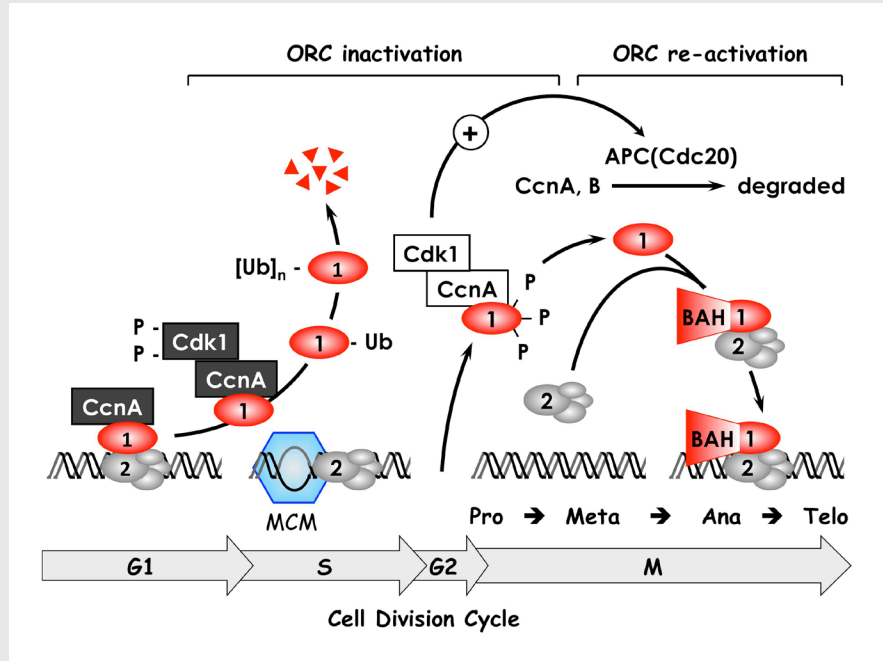

and location of replication origins in the cells of multicellular organisms can change from an average of one in every 10 to 20 kb in the rapidly cleaving embryos of frogs, flies, and fish to one in every 50 to 300 kb in the differentiated cells of adult organisms. Developmental changes in origin density also occur during specific stages in animal development. Thus, metazoan genomes contain many potential replication origins but, during development, some of these sites are selectively activated while others are suppressed, a concept introduced many years ago as the "Jesuit Model", because many are called, but few are chosen (DePamphilis ML, *Ann Rev Biochem* 1993;62:29; *Curr Opin Cell Biol* 1993;5:434; *J Biol Chem* 1993;268:1).

The ORC initiates assembly of prereplication complexes (preRCs) consisting of a DNA helicase loader [ORC(1–6) and replication factors Cdc6 and Cdt1] and the replicative DNA helicase [Mcm(2–7)]. Several years ago, we discovered that the behavior of ORC in mammalian cells differs significantly from that in single-cell eukaryotes such as yeast. In contrast to yeast, Orc1 associates weakly with the stable core complex ORC(2–5), and the ability of ORC to initiate DNA replication depends on this interaction. Moreover, it appears that the interaction of Orc1 with ORC(2–5) is one of the mechanisms that regulate when and where initiation events occur. We termed this concept the ORC cycle, and we and others have established its basic features (Figure 1). Cell cycle-dependent modifications of Orc1 regulate Orc1 activity, and Orc1 activity regulates ORC activity, which regulates initiation of DNA replication.

The ORC cycle is only one of six known mechanisms that can determine when and where DNA replication

begins in human cells. Cdk2•CcnA (cyclin-dependent kinase-2•cyclin A) also suppresses Cdc6 (cell vision cycle-6) and Cdt1 (chromatin licensing and DNA replication factor-1) activities by phosphorylation, and Cdt1 is targeted by two ubiquitin ligases and by geminin, a Cdt1-specific protein inhibitor (Figure 2). However, not every pathway is active in all cell types. For example, cells derived from human cancers are dependent on geminin to prevent DNA re-replication, whereas cells derived from normal human tissues are dependent on both geminin and cyclin A-dependent CDK (cyclin-dependent kinase) activity.

A rare event in mammals, endoreduplication, by which the nuclear portion of the genome is duplicated one or more times (endocycles) without an intervening mitosis, is a common event among arthropods and plants. In mammals, it first occurs during peri-implantation development when cells within the trophoctoderm (TE) of the blastocyst are deprived of the mitogenic factor FGF4 (fibroblast growth factor-4). Trophoblast stem (TS) cells then differentiate into the polyploid, viable, non-proliferating trophoblast giant (TG) cells required for embryo implantation and placentation (Figure 3). PreRC assembly requires the absence of both CDK activity and geminin, a condition that occurs in mitotic cell cycles during the anaphase-to-G1 phase transition. We discovered that this condition could be induced in TS cells by selective chemical inhibition of CDK1, the enzyme required for entry into mitosis, but not in embryonic stem (ES) cells, in which the consequence is apoptosis. Therefore, selective inhibition of CDK1 triggers endoreduplication only in cells programmed to differentiate into polyploid cells. Similarly, FGF4 deprivation of TS cells induced expression of two CDK-specific inhibitors: p57/Kip2 and p21/Cip1. One (p57) was essential for endoreduplication while the other (p21) appeared to facilitate p57 activity by suppressing expression of Chk1 (checkpoint

**FIGURE 2. Several convergent pathways restrict genome duplication to once per cell division.**

In human cells, activity of the replication factor Cdt1 is down-regulated in four ways. Free Cdt1 is phosphorylated by Cdk2 in association with cyclin A (CcnA), thereby suppressing Cdt1 activity and converting Cdt1 into a substrate for the CRL1<sup>Skp2</sup> ubiquitin ligase. As replication forks pass through the origin, Cdt1 binds to the proliferating cell nuclear antigen (PCNA) clamp, which holds the replicative DNA polymerase onto the replication fork. The Cdt1•PCNA•chromatin form of Cdt1 is a substrate for the CRL4<sup>Cdt2</sup> ubiquitin ligase. Ubiquitinated Cdt1 is then

degraded by the 26S proteasome. Finally, geminin binds to Cdt1 and inhibits its activity. In addition to inactivation of Cdt1, CcnA-dependent phosphorylation of Orc1 prevents it from binding to chromatin during mitosis, and CcnA-dependent phosphorylation of Cdc6 suppresses its activity and promotes its nuclear export.

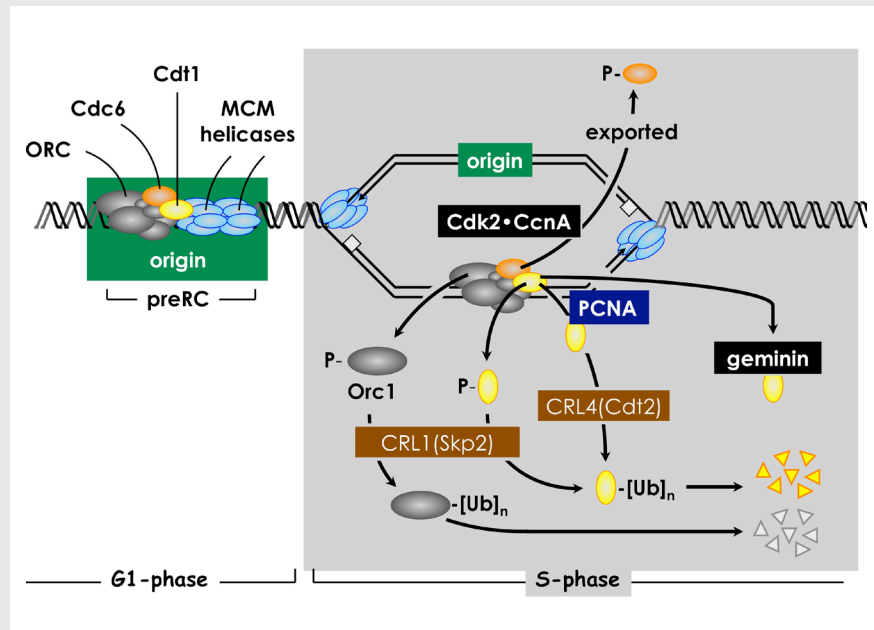
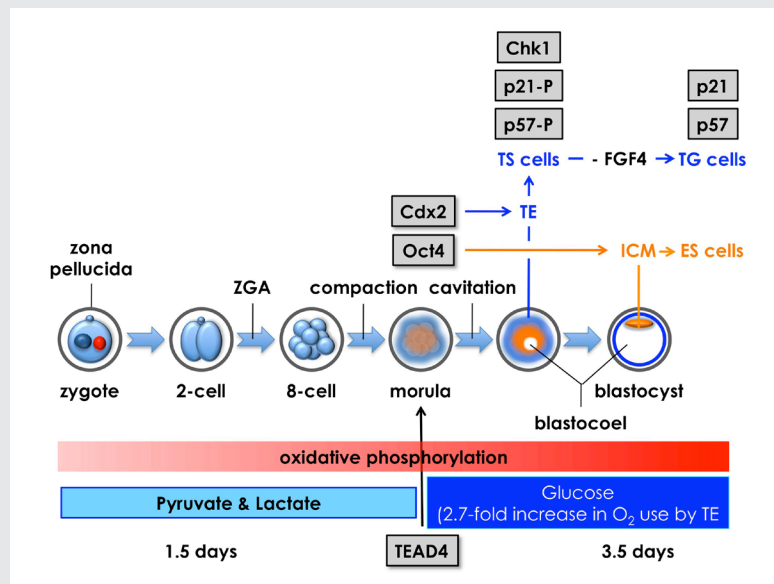



**FIGURE 3. Mouse pre-implantation development: zygotic gene activation (ZGA) begins at the two-cell stage.**

The eight totipotent blastomeres at the eight-cell stage compact into a morula, and transcription factors *Tead4*, *Cdx2*, and *Oct4* mark the beginning of a chain of events that specifies the trophoblast (TE) and inner cell mass (ICM). *Oct4* is the first gene whose expression is essential for maintaining blastomeres in a totipotent state, thereby producing the ICM and embryonic stem (ES) cells that differentiate into embryonic tissues. *Tead4* is the first gene whose expression is essential for differentiation of blastomeres into TE and trophoblast stem (TS) cells, which produce the placenta. In the absence of *Tead4* expression, all totipotent blastomeres produce OCT4 protein, revealing that the TEAD4 protein is required for *Cdx2* gene expression. However, TEAD4 is essential for blastocyst formation only under conditions that increase the rate of oxidative phosphorylation.

Following compaction, pre-implantation embryos switch energy substrates from pyruvate and lactate to glucose in order to meet the increased energy demands of blastocoel formation, an event unique to the TE. Thus, *Tead4* does not specify the TE; rather, TEAD4 maintains energy homeostasis so that other genes can specify the TE.



kinase-1) and the mitotic inhibitor Emi1 (Figure 4). TS cells (+FGF4) express both the *p57* and *p21* genes, but the non-activated form of Chk1 phosphorylates the *p57* and *p21* proteins, thereby targeting them for ubiquitin-dependent degradation. In TG cells, CHK1 is suppressed to allow *p57* expression during G phase, CDK2 is required for DNA replication, and *p57* is degraded during S phase to allow endocycles.

## DNA replication and cell differentiation during pre-implantation development

Fertilization activates the first round of genome duplication, after which the fertilized egg cleaves into a two-cell embryo (Figure 3). In mice, the two-cell embryo then activates expression of about 300 genes that are required to continue development of the organism (termed zygotic gene activation). Initially, every cell (blastomere) produced by the cleavage events is 'totipotent,' that is, it is capable of giving rise to the entire organism. But, within five rounds of cell cleavage, a blastocyst appears, marking the beginning of cell differentiation. The blastocyst consists of a spherical monolayer of epithelial cells called the TE that gives rise to TS cells, TG cells, and eventually to the placenta. The TE layer encompasses a group of cells called the inner cell mass, which gives rise to ES cells and eventually to the embryo.

For some years, our goal has been to determine whether the requirements for genome duplication in cultured cells are the same for cleavage-stage embryos, for the stage prior to cell differentiation, and for the transition from mitotic cell cycles to endocycles. To this end, we identified genes that we thought might be critical for pre-implantation development. The results have been fruitful, but surprising. We discovered that *Dkk11*, a gene unique to mammals, is expressed specifically during implantation of the embryo and

**FIGURE 4.** Proliferating trophoblast stem (TS) cells exhibit a G2 phase restriction point analogous to the G1 restriction point in proliferating cultured mammalian cells.

In the presence of the mitogen FGF4 and in the absence of DNA damage, Chk1, the same checkpoint kinase that is activated by DNA damage, phosphorylates both p57 and p21, thereby targeting them for ubiquitin-dependent degradation. In the absence of FGF4 and DNA damage, Chk1 expression is suppressed by an as yet unidentified mechanism. Both p57 and p21 proteins accumulate; p57 inhibits CDK1, and TS cells exit their mitotic cell cycle and differentiate into trophoblast giant (TG) cells; and p21 plays several roles, including suppressing Chk1 expression to maintain TG cell status and inhibiting Emi1 to activate the anaphase-promoting complex (APC), which promotes prereplication complex (preRC) assembly by targeting cyclins A and B and geminin for degradation. Both Chk1 and p21 are also components of the DNA-damage response that prevents mitosis until the problem is corrected; the features that distinguish their roles in the two regulatory mechanisms remain to be elucidated.

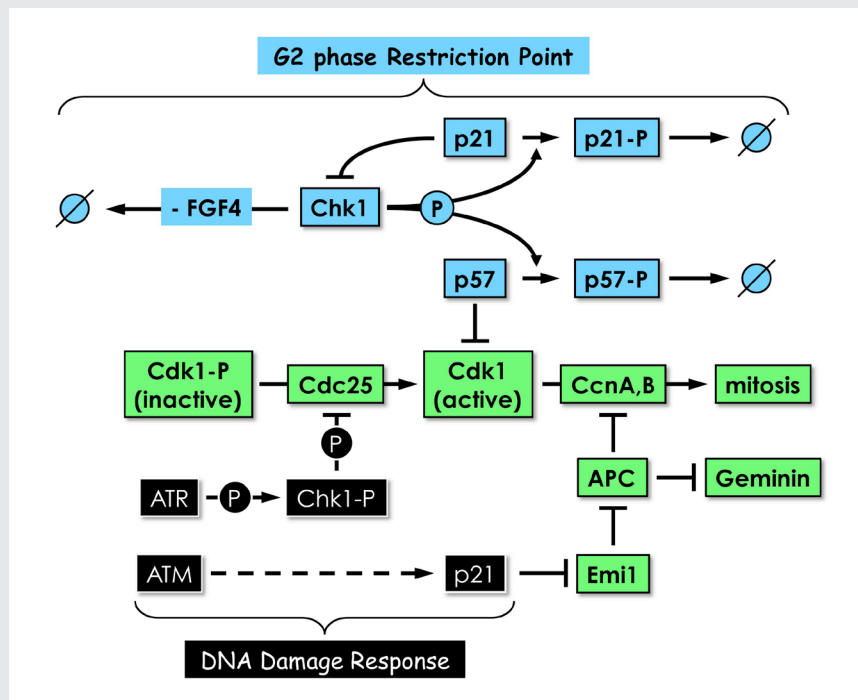

complex (preRC) assembly by targeting cyclins A and B and geminin for degradation. Both Chk1 and p21 are also components of the DNA-damage response that prevents mitosis until the problem is corrected; the features that distinguish their roles in the two regulatory mechanisms remain to be elucidated.

development of spermatocytes into sperm. Moreover, we showed that inactivation of *Dkk11* in mice resulted in the production of sperm that are defective in fertilization. We discovered that *Tead2*, the gene encoding one of a highly conserved family of four transcription factors that share a common DNA-binding domain, is expressed from the two-cell embryo throughout pre-implantation development but, remarkably, is not required until after implantation and the start of nervous system formation. Mice lacking a functional *Tead2* gene have difficulty forming a neural tube. Failure to close the neural tube in mice is called exencephaly, which is related to anencephaly, the common human birth defect that can be prevented by folic acid. We also discovered that *Tead2* and *Tead4* are the only *Tead* genes expressed in pre-implantation mouse embryos and that, in contrast to genetic inactivation of *Tead2*, genetic inactivation of *Tead4* results in the formation of a morphologically abnormal morula, the absence of TE-specific genes, and failure to produce a blastocoel. These and other results in the literature strongly suggested that *Tead4* is a master gene that sets in motion the first round of cell differentiation during mammalian development. Surprisingly, our subsequent research demonstrated otherwise.

Master genes trigger a sequence of events that specify cell fate. However, genes essential for maintaining a metabolic state that allows other genes to specify cell fate may be mistaken for master genes. We validated the concept by showing that *Tead4*, the presumptive master gene for trophectoderm specification, is a homeostatic gene that is essential for blastocoel formation *in utero*, a prerequisite for embryo implantation and placentation. Requirement for *Tead4* is induced metabolically, not developmentally, and conditions

that minimize oxidative stress allow embryos lacking TEAD4 to develop into blastocysts expressing genes required to produce functional trophoblast. TEAD4, which is expressed at the eight-cell stage, is essential only under conditions that promote energy production by oxidative phosphorylation (Figure 3). Given that either inhibition of the mTOR pathway or an anti-oxidant alleviates the requirement, TEAD4 appears to regulate changes in redox potential that are expected to occur during the high levels of oxidative phosphorylation associated with blastocyst formation *in utero* (Kaneko and DePamphilis, *Development* 2013;140:3680).

## And-1 coordinates with Claspin for efficient Chk1 activation in response to replication stress.

The replisome is important for DNA replication checkpoint activation, but how specific components of the replisome coordinate with ATR, a serine/threonine-specific protein kinase that is involved in sensing DNA damage and activating the DNA damage checkpoint, to activate Chk1 in human cells remains largely unknown. We demonstrated that And-1, a replisome component, acts together with ATR to activate Chk1. And-1 is phosphorylated at T826 by ATR following replication stress, and the phosphorylation is required for And-1 to accumulate at the damage sites, where And-1 promotes the interaction between Claspin and Chk1, thereby stimulating efficient Chk1 activation by ATR. Significantly, And-1 binds directly to single-stranded DNA (ssDNA) and facilitates the association of Claspin with ssDNA. Furthermore, And-1 associates with replication forks and is required for the recovery of stalled forks. These studies establish a novel ATR–And-1 axis as an important regulator for efficient Chk1 activation and reveal a novel mechanism whereby the replisome regulates the replication checkpoint and genomic stability.

## Geminin is essential to prevent DNA re-replication–dependent apoptosis in pluripotent cells, but not in differentiated cells.

Geminin is a dual-function protein unique to multicellular animals with roles in modulating gene expression and preventing DNA re-replication. We showed that geminin is essential at the beginning of mammalian development to prevent DNA re-replication in pluripotent cells, exemplified by ES cells, as they undergo self-renewal and differentiation. We characterized ES cells, embryonic fibroblasts, and immortalized fibroblasts before and after geminin was depleted either by gene ablation or small interfering RNA (siRNA). Depletion of geminin under conditions that promote either self-renewal or differentiation rapidly induced DNA re-replication, followed by DNA damage, then a DNA damage response, and finally apoptosis. Once differentiation had occurred, geminin was no longer essential for viability, although it continued to contribute to the prevention of DNA damage induced by DNA re-replication. We detected no relationship between expression of geminin and genes associated with either pluripotency or differentiation. Thus, the primary role of geminin at the beginning of mammalian development is to prevent DNA re-replication–dependent apoptosis, a role previously believed essential only in cancer cells. The results suggest that regulation of gene expression by geminin occurs only after pluripotent cells differentiate into cells in which geminin is not essential for viability.

## Identification of genes that are essential to restrict genome duplication to once per cell division

The mechanism that duplicates the nuclear genome during the trillions of cell divisions required to develop from zygote to adult is the same throughout the eukarya, but the mechanisms that determine where, when, and how much nuclear genome duplication occurs differ among the eukarya. They allow organisms to

change the rate of cell proliferation during development, to activate zygotic gene expression independently of DNA replication, and to restrict nuclear DNA replication to once per cell division. They allow specialized cells to exit their mitotic cell cycle and differentiate into polyploid cells and, in some cases, to amplify the number of copies of specific genes. It is genome duplication that drives evolution, by virtue of the errors that inevitably occur when the same process is repeated trillions of times. They are, unfortunately, the same errors that produce age-related genetic disorders such as cancer.

Nuclear genome duplication is normally restricted to once per cell division, but aberrant events that allow excess DNA replication (EDR) promote genomic instability and aneuploidy, both of which are characteristics of cancer development. We provided the first comprehensive identification of genes that are essential to restrict genome duplication to once per cell division. We screened an siRNA library of 21,584 human genes for those that prevent EDR in cancer cells with undetectable chromosomal instability. We validated candidates by testing multiple siRNAs and chemical inhibitors on both TP53<sup>+</sup> (tumor protein p53) and TP53<sup>-</sup> cells to reveal the relevance of this ubiquitous tumor suppressor in preventing EDR, and in the presence of an apoptosis inhibitor to reveal the full extent of EDR. The results revealed 42 genes that prevented either DNA re-replication or unscheduled endoreplication. They all participate in one or more of eight cell-cycle events. Seventeen had not been identified previously in this capacity. Remarkably, 14 of the 42 genes have been shown to prevent aneuploidy in mice. Moreover, suppressing a gene that prevents EDR increased the ability of the chemotherapeutic drug Paclitaxel to induce EDR, suggesting new opportunities for synthetic lethality in the treatment of human cancers.

## Publications

1. Huang YY, Kaneko KJ, Pan H, DePamphilis ML. Geminin is essential to prevent DNA re-replication-dependent apoptosis in pluripotent cells, but not in differentiated cells. *Stem Cells* 2015 33(11):3239-3253.
2. Hao J, de Renty C, Li Y, Xiao H, Kemp MG, Han Z, DePamphilis ML, Zhu W. And-1 coordinates with Claspin for efficient Chk1 activation in response to replication stress. *EMBO J* 2015 34:2096-2110.
3. Vassilev A, Lee CY, Vassilev B, Zhu W, Ormanoglu P, Martin SE, DePamphilis ML. Identification of genes that are essential to restrict genome duplication to once per cell division. *Oncotarget* 2016 7:34956-34976.
4. DePamphilis ML. Genome duplication: the heartbeat of developing organisms. *Curr Top Dev Biol* 2016 116:201-229.
5. DePamphilis ML. Genome duplication at the beginning of mammalian development. *Curr Top Dev Biol* 2016 120:55-102.
6. DePamphilis, ML (Editor). Mammalian Preimplantation Development. *Curr Top Dev Biol* 2016 120:1-478.

## Collaborators

- Scott E. Martin, PhD, *NIH Chemical Genomics Center, NHGRI, Rockville, MD*
- Wenge Zhu, PhD, *George Washington University Medical School, Washington, DC*

## Contact

For more information, email [depamphm@mail.nih.gov](mailto:depamphm@mail.nih.gov) or visit <http://depamphilislab.nichd.nih.gov>.

## Mechanism and Regulation of Eukaryotic Protein Synthesis

We study the mechanism and regulation of protein synthesis, focusing on GTPases and protein kinases that control this fundamental cellular process. We use molecular-genetic and biochemical studies in yeast and human cells to dissect the structure-function properties of translation factors. Of special interest are the translation initiation factors eIF2, a GTPase that binds methionyl-tRNA to the ribosome, and eIF5B, a second GTPase that catalyzes ribosomal subunit joining in the final step of translation initiation. We also investigate stress-responsive protein kinases that phosphorylate eIF2alpha, viral regulators of these kinases, and how cellular phosphatases are targeted to dephosphorylate eIF2alpha. We are characterizing eIF2gamma mutations that are associated with a novel X-linked intellectual disability syndrome, and we are investigating the function of the translation factor eIF5A with a focus on its ability to stimulate the peptidyl transferase activity of the ribosome and facilitate the reactivity of poor substrates such as proline. We are also examining the role of the hypusine modification on eIF5A and the role of this factor in gene-specific translational control mechanisms.

### Analysis of eIF2gamma mutations that link intellectual disability with impaired translation initiation

The first step of protein synthesis is binding of the initiator Met-tRNA to the small ribosomal subunit by the factor eIF2, which is composed of three subunits. The gamma subunit of eIF2 is a GTPase that resembles the bacterial translation elongation factor EF-Tu. We previously showed that, despite their structural similarity, eIF2 and EF-Tu bind to tRNA in substantially different manners, and we showed that the tRNA-binding domain III of EF-Tu has acquired a new function in eIF2gamma to bind to the ribosome.

While protein synthesis plays a critical role in learning and memory in model systems, human intellectual disability syndromes have not been directly associated with alterations in protein synthesis. Working with collaborators in Israel and Germany, we investigated a human X-linked disorder characterized by intellectual disability, epilepsy, hypogonadism, microcephaly, and obesity. The patients



**Thomas E. Dever, PhD, Head,**  
*Section on Protein Biosynthesis*  
Chune Cao, *Biological Laboratory*  
*Technician*

Ivaylo P. Ivanov, PhD, *Research*  
*Fellow*

Joo-Ran Kim, BS, *Special Volunteer*  
Leda Lotspeich-Cole, BS, *Graduate*  
*Student*

Jason A. Murray, BS, *Graduate*  
*Student*

Byung-Sik Shin, PhD, *Staff Scientist*

Arya Vindu, PhD, *Visiting Fellow*

Sara Young, PhD, *Postdoctoral*  
*Fellow*

carry a mutation in the *EIF2S3* gene, which encodes eIF2gamma. In genetic and biochemical studies, we found that the mutation disrupts eIF2 complex integrity, impairs general translation, alters translational control of mRNAs encoding key regulatory proteins, and reduces the fidelity of translation start codon selection. The findings directly link intellectual disability with impaired translation initiation and provide a mechanistic basis for the human disease resulting from partial loss of eIF2 function (Reference 1). Over the past year, working with additional collaborators, we have been characterizing other mutations in eIF2gamma that cause intellectual disability and we linked these mutations to the MEHMO (Mental retardation, Epileptic seizures, Hypogenitalism, Microcephaly and Obesity) syndrome.

## Molecular analysis of eIF2alpha phosphorylation, dephosphorylation, and viral regulation

Phosphorylation of the eIF2alpha subunit is a common mechanism for down-regulating protein synthesis under stress conditions. Four distinct kinases phosphorylate eIF2alpha on Ser51 under different cellular stress conditions: GCN2 responds to amino-acid limitation, HRI to heme deprivation, PERK to ER (endoplasmic reticulum) stress, and PKR to viral infection. Consistent with their common activity to phosphorylate eIF2alpha on Ser51, the kinases show strong sequence similarity in their kinase domains. Phosphorylation of eIF2alpha converts eIF2 from a substrate to an inhibitor of its guanine-nucleotide exchange factor eIF2B. The inhibition of eIF2B impairs general translation, slowing the growth of yeast cells and, paradoxically, enhancing the translation of the GCN4 mRNA (GCN4 is a transcription factor) required for yeast cells to grow under amino-acid starvation conditions.

We previously used structural, molecular, and biochemical studies to define how the eIF2alpha kinases recognize their substrate. In collaboration with Frank Sicheri, we obtained the X-ray structure of eIF2alpha bound to the catalytic domain of PKR. Based on our studies, we proposed an ordered mechanism of PKR activation by which catalytic domain dimerization triggers auto-phosphorylation, which in turn is required for specific eIF2alpha substrate recognition. Moreover, our studies on eIF2alpha led us to propose that the Ser51 phosphorylation site is protected in free eIF2alpha, which prevents promiscuous phosphorylation and attendant translational regulation by heterologous kinases. Upon interaction with an eIF2alpha kinase, the Ser51 residue is exposed and phosphorylated by the kinase.

While the protein kinases GCN2, HRI, PKR, and PERK specifically phosphorylate eIF2alpha on Ser51 to regulate global and gene-specific mRNA translation, eIF2alpha is dephosphorylated by the broadly acting serine/threonine protein phosphatase 1 (PP1). In mammalian cells, the regulatory subunits GADD34 and CREP target PP1 to dephosphorylate eIF2alpha. We showed that a novel N-terminal extension on yeast eIF2gamma binds to yeast PP1 (GLC7) and targets GLC7 to dephosphorylate eIF2alpha. Continuing our studies on eIF2alpha dephosphorylation, we reconstituted human GADD34 function in yeast cells. We mapped a novel eIF2a-binding motif to the C-terminus of GADD34 in a region distinct from that where PP1 binds to GADD34. Point mutations altering the 19-residue eIF2alpha-binding motif impaired the ability of GADD34 to interact with eIF2alpha, promote eIF2alpha dephosphorylation, and suppress PKR toxicity in yeast. Interestingly, the eIF2alpha-docking motif is conserved among several viral orthologs of GADD34, and we showed that it is necessary for the proteins produced by African swine fever virus, Canarypox virus, and Herpes simplex virus to promote eIF2alpha dephosphorylation. Taken together, our data demonstrate that GADD34 and its viral orthologs direct specific dephosphorylation of eIF2alpha by interacting with both PP1 and eIF2alpha through independent binding motifs (Reference 2).

The eIF2alpha kinase PKR is part of the cellular anti-viral defense mechanism. When expressed in yeast, human PKR phosphorylates eIF2alpha, resulting in inhibition of protein synthesis and yeast cell growth. To subvert the anti-viral defense mediated by PKR, viruses produce inhibitors of the kinase. The poxviral protein E3L binds to double-stranded RNA and inhibits PKR by sequestering activators and forming heterodimers with the kinase. We previously showed that a Z-DNA-binding domain near the N-terminus of E3L, but not its Z-DNA-binding activity, is critical for E3L inhibition of PKR. We are currently characterizing mutations in PKR that confer resistance to E3L inhibition. Similarly, we previously discovered that the insect baculovirus PK2 protein is an eIF2alpha kinase inhibitor. PK2 structurally mimics the C-terminal lobe of a protein kinase domain. Genetic screens, yeast two-hybrid assays, and protein-interaction studies revealed that PK2 associates with the N-lobe of PKR. Using yeast-based assays, we showed that PK2 was most effective at inhibiting an insect HRI-like kinase, and our collaborators showed that knockdown of the HRI-like kinase in insects rescued viral defects associated with loss of PK2. We proposed an inhibitory mechanism whereby PK2 engages the N-lobe of an eIF2alpha kinase domain to create a nonfunctional pseudokinase domain complex, possibly through a lobe-swapping mechanism (Reference 3).

## Molecular analysis of the hypusine-containing protein eIF5A

The translation factor eIF5A, the sole protein containing the unusual amino acid hypusine [*N*<sup>ε</sup>-(4-amino-2-hydroxybutyl)lysine], was originally identified based on its ability to stimulate a model assay for first peptide-bond synthesis. However, the precise cellular role of eIF5A was unknown. Using molecular-genetic and biochemical studies, we previously showed that eIF5A promotes translation elongation and that this activity depends on the hypusine modification. Given that eIF5A is a structural homolog of the bacterial protein EF-P, we proposed that eIF5A/EF-P is a universally conserved translation elongation factor.

Recently, it was shown that EF-P promotes translation of polyproline sequences by bacterial ribosomes. Using *in vivo* reporter assays, we showed that eIF5A in yeast stimulates the synthesis of proteins containing runs of three or more consecutive proline residues. Consistently, the expression of native yeast proteins containing homopolyproline sequences was impaired in eIF5A mutant strains. To support the *in vivo* findings, we used reconstituted yeast *in vitro* translation assays to monitor the impact of eIF5A on protein synthesis. We found that the synthesis of polyproline peptides, but not of polyphenylalanine peptides, was critically dependent on addition of eIF5A. Consistent with the functions of eIF5A in promoting peptide bond synthesis, directed hydroxyl radical probing experiments localized eIF5A binding to near the E site of the ribosome. Thus, we propose that eIF5A, like its bacterial ortholog EF-P, stimulates the peptidyl-transferase activity of the ribosome and facilitates the reactivity of poor substrates such as proline (Reference 4).

Over the last year, and working with the X-ray crystallographer Marat Yusupov, we obtained a 3.25 Å resolution crystal structure of eIF5A bound to the yeast 80S ribosome. The structure reveals interactions between eIF5A and conserved ribosomal proteins and rRNA bases. Moreover, eIF5A occupies the E site of the ribosome, with the hypusine residue projecting toward the acceptor stem of the P-site tRNA. Our studies reveal a previously unseen conformation of an eIF5A-ribosome complex, suggest a function for eIF5A and its hypusine residue in repositioning the peptidyl-tRNA in the P site to alleviate stalling, and they highlight a possible functional link between conformational changes of the ribosome during protein synthesis and eIF5A-ribosome association (Reference 5). In ongoing studies, we are characterizing translational control mechanisms that exploit the fact that polyproline synthesis requires eIF5A.

## Analysis of the role of eEF2 and its diphthamide modification in translation elongation and CrPV IRES translation

Together with collaborator Venki Ramakrishnan, we are studying the translation elongation factor eEF2. The eEF2, like its bacterial ortholog EF-G, promotes translocation of tRNAs and mRNA on the ribosome following peptide bond formation. In all eukaryotes and archaea, a conserved histidine residue at the tip of eEF2 is post-translationally modified to diphthamide through the action of seven non-essential proteins. The function of diphthamide and rationale for its evolutionary conservation are not well understood, and to date the only known function of diphthamide is to serve as a substrate for inactivation by diphtheria toxin. To gain insights into the role of eEF2 and diphthamide, we reconstituted the function of the cricket paralysis virus (CrPV) internal ribosome entry site (IRES) in a yeast *in vitro* translation assay system. The CrPV IRES is unique in bypassing the requirement for any translation initiation factors. Thus, the IRES binds directly to the A-site of the ribosome. Following eEF2-directed pseudo-translocation of the IRES to the P site, an aminoacyl-tRNA binds to the A-site followed by a second pseudo-translocation to move the IRES to the E site and the A-site tRNA to the P site. Following binding of the next aminoacyl-tRNA to the A site and ribosome-catalyzed peptide bond formation, normal translation elongation ensues, requiring the factors eEF1A and eEF2 and the yeast-specific factor eEF3. Using the canonical initiation pathway to direct the synthesis of the peptide Met-Phe-Lys revealed no distinction between unmodified eEF2 and eEF2 with the diphthamide modification. In contrast, synthesis of the same peptide directed by the CrPV IRES was sensitive to loss of diphthamide. As the pseudo-translocation steps are the main distinguishing feature of the CrPV IRES system, we propose that the precise phasing of pseudo-translocation is dependent on the diphthamide modification on eEF2.

Consistent with this interpretation, using electron cryomicroscopy, our collaborators revealed that eEF2 stabilizes the ribosome-IRES complex in a rotated state with key residues in domain IV of eEF2 interacting with the CrPV-IRES and stabilizing it in a conformation reminiscent of a hybrid tRNA state. Interestingly, diphthamide appears to interact directly with the tRNA-mimicking pseudo-knot I of the CrPV IRES, perhaps to facilitate its precise translocation in the ribosome and to break decoding interactions between conserved rRNA bases and the pseudo-knot. Thus, our studies provide the first evidence that diphthamide plays a role in protein synthesis, and we propose that diphthamide functions to disrupt the decoding interactions of rRNA in the A-site and to maintain codon-anticodon interactions as the A-site tRNA is translocated to the P site (Reference 6).

## Publications

1. Borck G, Shin BS, Stiller B, Mimouni-Bloch A, Thiele H, Kim JR, Thakur M, Skinner C, Aschenbach L, Smirin-Yosef P, Har-Zahav A, Nürnberg G, Altmüller J, Frommolt P, Hofmann K, Konen O, Nürnberg P, Munnich A, Schwartz CE, Gothelf D, Colleaux L, Dever TE, Kubisch C, Basel-Vanagaite L. eIF2gamma mutation that disrupts eIF2 complex integrity links intellectual disability to impaired translation initiation. *Mol Cell* 2012 48:641-646.
2. Rojas M, Vasconcelos G, Dever TE. An eIF2alpha-binding motif in protein phosphatase 1 subunit GADD34 and its viral orthologs is required to promote dephosphorylation of eIF2alpha. *Proc Natl Acad Sci USA* 2015 112:E3466-3475.
3. Li JJ, Cao C, Fixsen SM, Young JM, Ono C, Bando H, Elde NC, Katsuma S, Dever TE, Sicheri F. Baculovirus protein PK2 subverts eIF2a kinase function by mimicry of its kinase domain C-lobe. *Proc Natl Acad Sci USA*



2015 112:E4364-4373.

4. Gutierrez E, Shin BS, Woolstenhulme CJ, Kim JR, Saini P, Buskirk AR, Dever TE. eIF5A promotes translation of polyproline motifs. *Mol Cell* 2013 51:35-45.
5. Melnikov S, Mailliot J, Shin BS, Rigger L, Yusupova G, Micura R, Dever TE, Yusupov M. Crystal structure of hypusine-containing translation factor eIF5A bound to a rotated eukaryotic ribosome. *J Mol Biol* 2016 428:3570-3576.
6. Murray J, Savva CG, Shin BS, Dever TE, Ramakrishnan V, Fernández IS. Structural characterization of ribosome recruitment and translocation by type IV IRES. *Elife* 2016 5:e13567.

## Collaborators

- Lina Basel-Vanigaitte, MD, *Tel Aviv University, Tel Aviv, Israel*
- Guntram Borck, MD PhD, *Universität Ulm, Ulm, Germany*
- Alan Hinnebusch, PhD, *Section on Nutrient Control of Gene Expression, NICHD, Bethesda, MD*
- Venkatraman Ramakrishnan, PhD, *MRC Laboratory of Molecular Biology, Cambridge, United Kingdom*
- Frank Sicheri, PhD, *Samuel Lunenfeld Research Institute, Mount Sinai Hospital, and University of Toronto, Toronto, Canada*
- Marat Yusupov, PhD, *L'Institut de Génétique et de Biologie Moléculaire et Cellulaire (IGBMC), Strasbourg, France*

## Contact

For more information, email [thomas.dever@nih.gov](mailto:thomas.dever@nih.gov) or visit <http://spb.nichd.nih.gov>.

## Receptors and Actions of Peptide Hormones and Regulatory Proteins in Endocrine Mechanisms

We investigate the molecular basis of peptide hormone control of gonadal function, with particular emphasis on the structure and regulation of the genes encoding the luteinizing hormone receptor (LHR) and prolactin (PRL) receptor (PRLR). We also investigate the regulatory mechanism(s) involved in the progression of spermatogenesis and the control of Leydig cell (LC) function. Our studies focus on the regulation of human *LHR* transcription (nuclear orphan receptors, epigenetics, DNA methylation, second messengers, repressors, corepressors, and coactivators), as well as on the multiple-promoter control of *hPRLR* gene transcription. We are elucidating the relevance of PRL, estradiol and its receptor (liganded or un-liganded), epidermal growth factor (EGF), the EGF receptors ERRBB1/EGFR and ERRB2/HER2 in the up-regulation of the PRLR, and their mechanistic commonalities for definition of PRL/PRLR-induced progression and metastasis of breast tumors and their role in persistent invasiveness in certain states refractory to adjuvant endocrine therapies. We also investigate novel gonadotropin-regulated genes relevant to the progression of testicular gametogenesis, LC function, and other endocrine processes. We focus on the function and regulation of the gonadotropin-regulated testicular RNA helicase (GRTH/DDX25), an essential post-transcriptional regulator of spermatogenesis, which was discovered, cloned, and characterized in our laboratory. The various functions of GRTH/DDX25 provide a fertile ground for the development of a male contraceptive.

### The luteinizing hormone receptor

LHR is expressed primarily in the gonads, where it mediates LH signals, which regulate either cyclic ovarian changes or testicular function. The *LHR* transcription gene is controlled by complex and diverse networks, in which coordination and interactions between regulatory effectors are essential for silencing/activation of *LHR* expression. The proximal promoter site for the transcription factor Sp1 recruits histone (H) deacetylases (HDAC) and the Sin3A (a transcriptional regulatory protein) corepressor complex, which contributes to the silencing of *LHR* transcription. Site-specific acetylation/methylation-induced phosphatase release serves as an on switch for Sp1 phosphorylation at Ser641, which causes p107



**Maria L. Dufau, MD, PhD,**  
*Head, Section on Molecular  
Endocrinology*

Raghuveer Kavarthapu, PhD, *Staff  
Fellow*

Peng Zhao, PhD, *Postdoctoral  
Fellow*

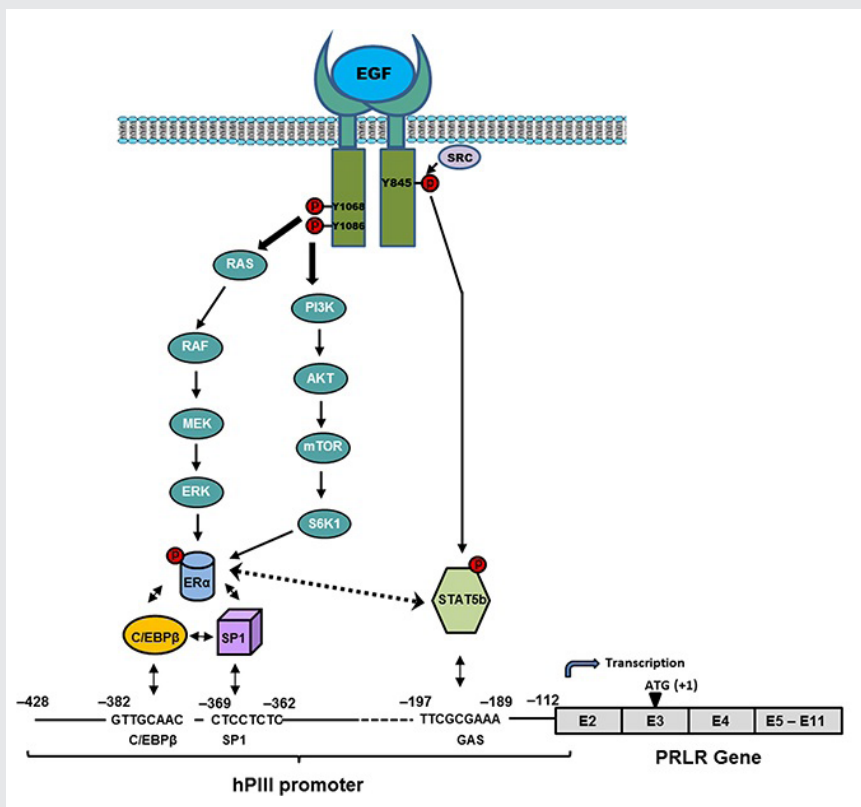

FIGURE 1. Mechanism of up-regulation of the prolactin receptor (PRLR) by epidermal growth factor (EGF)/epidermal growth factor receptor (EGFR) independent of estradiol and endogenous prolactin

Signal transduction mechanisms induced by EGF via EGFR, causing activation of transcription factors that are required for *PRLR* gene activation through the hPrlR (human PIII) promoter of PRLR and consequent increased expression of the receptor in MCF-7 cells

repressor release from Sp1, recruitment of Transcription Factor II B (TFIIB) and RNA polymerase II (Pol II), and transcriptional activation. Maximal derepression of the gene is dependent on DNA demethylation of the promoter, on H3/acetylation, and on HDAC/Sin3A release. Positive Cofactor 4 (PC4) has an important role in the formation assembly of the preinitiation complex (PIC) in trichostatin A (TSA)-mediated *LHR* transcription. It is recruited by Sp1 following TSA treatment and acts as a coactivator. However, PC4 does not participate in TSA release of phosphatases, Sp1 phosphorylation, or release of repressor or complexes. Although TFIIB recruitment is dependent on PC4, we ruled out TFIIB, as its direct target, and acetylation of PC4 in the activation process. However, we demonstrated TSA-induced acetylation of PC4-interacting proteins, identified as acetylated H3 by mass spectrometry, and PC4's presence in the complex, in association with chromatin at the promoter, was demonstrated by ChIP/reChIP. The role of these interactions on chromatin structure and their participation in the assembly of the PIC and transcriptional activation are under investigation. To elucidate the physiological impact of PC4 on Sp1-directed transcription in gonads, we generated a cell-specific knockout (KO) by breeding *PC4*-floxed mice with transgenic mice expressing tissue-specific *Cyp17* Cre. We are now analyzing *PC4* null-mice with a specific deletion in testicular Leydig cells.

## Gonadotropin-regulated testicular RNA helicase

Gonadotropin-regulated testicular RNA helicase (GRTH/DDX25) is a testis-specific member of the DEAD-box family of RNA helicases present in Leydig cells (LC) and meiotic germ cells and is essential for the completion of spermatogenesis. Males lacking GRTH are sterile owing to the absence of sperm resulting from failure of round spermatids to elongate. Besides its intrinsic RNA helicase activity, it is a shuttling protein that

exports specific mRNAs from the nucleus to cytoplasmic sites. Our studies demonstrated the essential participation of GRTH-mediated export/transport of mRNAs in the structural integrity of the Chromatoid Body (storage/processing of mRNAs) and of their transit/association to actively translating polyribosomes, where GRTH may regulate translational initiation of genes. GRTH is regulated by LH through androgen at the transcriptional level in LCs (directly), with impacts in steroidogenesis, and germ cells (indirectly via androgen receptor in Sertoli cells); GRTH's expression is both cell- and stage-specific. The helicase displays negative autocrine control of androgen production in LCs by preventing overstimulation of the LH-induced androgen pathway through enhanced degradation of the StAR protein (steroidogenic acute regulatory protein). In this manner, GRTH controls the degree of cholesterol transport to the mitochondria and its availability for steroidogenesis. Transgenic mouse models carrying a *GRTH* 5' flanking region-GFP reporter provided *in vivo* systems that permit differential elucidation of regions in the *GRTH* gene that direct the gene's expression (upstream; -6.4/-3.6kb) in germ cells (pachytene spermatocytes and round spermatids) and downstream in LCs as well as of the gene's direct regulation by androgen/androgen receptor (A/AR) in LCs and indirect regulation in germ cells.

A functional binding site for the germ cell-specific transcription factor Germ Cell Nuclear Factor (GCNF) resides in the distal region, -5270/-5252, of the *GRTH* gene, and we identified its paracrine regulation by androgen at this site (Reference 3), which is cell-specific and occurs exclusively in round spermatids (RS). GCNF is a member of the orphan nuclear receptor superfamily that is expressed in the nucleus of spermatocytes and spermatids of adult mice. GCNF is essential for *GRTH* expression in germ cells. GCNF knock-down in round spermatids preparations from testis of transgenic mice reduced GFP/*GRTH* expression upon *in vivo* treatment of mice with Flutamide (Flu), an AR antagonist. Moreover, Flu treatment of wild-type mice caused selective reduction of *GRTH* in round spermatids. The studies provided evidence for actions of androgen on GCNF cell-specific regulation of *GRTH* expression in germ cells. Also, *GRTH* associates with GCNF mRNA, and its absence causes an increase in GCNF expression and mRNA stability, indicative of negative autocrine regulation of GCNF by *GRTH*. Our *in vivo* and *in vitro* models link paracrine androgen action with two relevant germ-cell genes essential for the progress of spermatogenesis and established their regulatory interrelationship. The studies provide valuable insights and facilitate what could be a difficult search for androgen/androgen receptor-mediated gene products in Sertoli cells that affect germ cell function and spermatogenesis.

## The prolactin receptor

The human prolactin receptor (PRLR) mediates the diverse cellular actions of prolactin (PRL). PRL plays a major role in the proliferation and differentiation of breast epithelium and is essential for stimulation and maintenance of lactation. It plays an important role in the etiology and progression of breast cancer, tumoral growth, and chemo-resistance. PRLR expression is controlled at the transcriptional level by several promoters, one generic (PIII), which lacks an estrogen response element (ERE) and is preferentially utilized, and five human-specific (hPN1-hPN5), which we defined and characterized in our laboratory. Each promoter directs transcription/expression of a specific non-coding exon 1, a common non-coding exon 2, and coding exons (E3-E11). Complex formation of the estrogen receptor alpha (ER $\alpha$ ) homodimer (non-DNA bound) with the transcription factor Sp1 and dimers of the transcription factor C/EBP $\beta$ , bound to their sites at the PIII promoter, is required for basal (constitutive ER $\alpha$  homodimers) and estradiol (E2)-induced transcriptional activation/expression of the human *PRLR* gene.

In tumoral breast, PRL causes cell proliferation by activating its cognate receptor. Exacerbation of PRL's actions in breast cancer, resulting from increased receptor expression, can explain resistance to estrogen inhibitors in breast cancer. Using MCF7 breast cancer estrogen-responsive (ER<sup>+</sup>)/oncogene HER2-positive (HER2<sup>+</sup>) cells, we recently demonstrated that, in the absence of E2, exogenous/endogenous PRL upregulated *PRLR* transcription/expression, with essential participation of ER $\alpha$  and of the JAK2/STAT5, mitogen-activated protein kinase (MAPK), and PI3K pathways. This occurs by interaction of phosphorylated ER $\alpha$  (generated by PRL/PRLR/JAK2) associated with Sp1 and C/EBP $\beta$  with STAT5A and STAT5B bound to a nucleotide sequence, known as a GAS element, in the PIII promoter. We also found that ERBB2/HER2, which is expressed in 10% of breast tumors, phosphorylated and activated by JAK2 via PRL/PRLR, induces ER $\alpha$  phosphorylation. Such cross-talk activation of ERBB2/HER2 signaling was identified as an alternate route for the PRLR increase, which is abolished by mutation of the GAS site (Stat5 DNA-recognition motif), by Stat5 siRNA, or by an ER antagonist (ICI). This indicates that ER $\alpha$  participates in PRLR transcription via PRL/PRLR/Stat5. PRL/PRLR induces phosphorylation of ER $\alpha$  through the JAK2/PI3K/MAPK/ERK- and HER2-activated pathways (Reference 1). Increased recruitment of phospho-ER $\alpha$  to Sp1 and C/EBP $\beta$  bound at promoter sites is essential for PRL-induced receptor transcription. Direct evidence for local actions of PRL independent of E2 is provided by the up-regulation of *PRLR* transcription/expression via the Stat5/ER $\alpha$  activation loop, with requisite participation of signaling mechanisms. These studies, which demonstrated a central role ER $\alpha$  in PRLR receptor up-regulation, are of relevance in states refractory to aromatase inhibitors, in which cancer progression can be fueled by endogenous PRL. Therapies that inhibit the function of PRL or PRLR, combined with inhibitors of various signaling pathways, could reverse resistance in breast cancer. Moreover, a combination therapy targeting ER and PRLR directly can offer an additional avenue to eliminate constitutive activation of ER and of PRLR by endogenous prolactin.

Paracrine inputs have an active role in breast tumor development, progression, and metastasis. Stromal fibroblasts secrete epidermal growth factor (EGF), which, through its receptor EGFR/ERRB1 present in breast tumors cells, activates signaling pathways, which in turn trigger requisite transcription factors and coactivators that can affect the proliferation of breast tumor cells. Our recent work addressed the role of EGFR in the up-regulation of the PRLR, given that most breast cancers that become resistant to endocrine therapy have elevated expression/activation of EGFR and its family member ERBB2. We showed, in MCF7 cells, marked activation of PRLR gene transcription/expression by exogenous EGF independent of PRL/PRLR/JAK2 or E2, with essential involvement of the MAPK, ER1/2, and PI3K-AKT signaling pathways (Reference 5). For their recruitment to the PRLR PIII promoter, these are mediated by EGFR tyrosines 1068 and 1086 and the tyrosine kinase cSRC-dependent EGFR tyrosine 845 for ER $\alpha$  and STAT5b phosphorylation, respectively (Figure 1). Apart from its independence of E2 and the activator requirements (PRL vs. EGF), there are important commonalities (prerequisite for ER $\alpha$  and STAT5) in the mechanism of PRLR transcription/expression. Moreover, the studies revealed that STAT 5 interaction with ER $\alpha$  is essential for PRLR up-regulation. Our findings provide mechanistic avenues whereby, upon resistance to hormonal therapy, an increase of PRLR could promote progression and metastasis in breast cancer.

## Publications

1. Kavarthapu R, Tsai Morris CH, Dufau ML. Prolactin induces up-regulation of its cognate receptor in breast cancer cells via transcriptional activation of its generic promoter by cross-talk between ER $\alpha$  and STAT5. *Oncotarget* 2014 5:9079-9091.

2. Yang, R, Tsai-Morris CH, Kang JH, Dufau ML. Elucidation of RNA binding regions of gonadotropin-regulated testicular RNA helicase (GRTH/DDX25) to transcripts of a chromatin remodeling protein essential for spermatogenesis. *Horm Mol Biol Clin Investig* 2015 22:119-130.
3. Kavarthapu R, Dufau ML. Germ Cell Nuclear (GCNF/RTR) regulates transcription of gonadotropin-regulated testicular RNA helicase (GRTH/DDX25) in testicular germ cells - the androgen connection. *Mol Endocrinol* 2015 29:1792-1804.
4. Chason RJ, Kang J-H, Gerkowicz SA, Dufau ML, Catt KJ, Segars JH. GnRH agonist reduces estrogen receptor dimerization in GT1-7 cells: Evidence for cross-talk between membrane-initiated estrogen and GnRH signaling. *Mol Cell Endocrinol* 2015 404:67-74.
5. Kavarthapu R, Dufau ML. Role of EGF/ERBB1 in the transcriptional regulation of the prolactin receptor independent of estrogen and prolactin in breast cancer cells. *Oncotarget* 2016; E-pub ahead of print.

## Collaborators

- James M. Pickel, PhD, *Transgenic Core Facility, NIMH, Bethesda, MD*
- James H. Segars, MD, *Unit on Reproductive Endocrinology and Infertility, NICHD, Bethesda, MD*

## Contact

For more information, email [dufau@helix.nih.gov](mailto:dufau@helix.nih.gov) or visit <https://irp.nih.gov/pi/maria-dufau>.

## Nervous System Development and Plasticity

Healthy brain and cognitive development in children is central to the mission of NICHD. Unlike the brains of most animals, the human brain continues to develop postnatally, through adolescence and into early adulthood. The prolonged postnatal period of brain development allows environmental experiences to influence brain structure and function, rather than having brain function specified entirely by genes. Activity-dependent plasticity also compensates for developmental defects and brain injury. Our research is concerned with understanding the molecular and cellular mechanisms by which functional activity in the brain regulates development of the nervous system during late stages of fetal development and early postnatal life. We are especially interested in novel mechanisms of activity-dependent nervous system plasticity that are particularly relevant to the period of childhood and of those that operate beyond the synapse and beyond the neuron doctrine. Our work has three main areas of emphasis: myelination and neuron-glia interactions, cellular mechanisms of learning, and gene regulation by neuronal firing.

Traditionally, the field of activity-dependent nervous system development has focused on synapses, and we continue to explore synaptic plasticity. However, our research is also advancing understanding of how non-neuronal brain cells (glia) sense neural impulse activity and how activity-dependent regulation of glia contributes to development, plasticity, and the cellular mechanisms of learning. A major emphasis of our current research is to understand how myelin (white matter in the brain) is regulated by functional activity. By changing conduction velocity, activity-dependent myelination may be a non-synaptic form of plasticity, regulating nervous system function by optimizing the speed and synchrony of information transmission through neural networks. Our studies identified several cellular and molecular mechanisms for activity-dependent myelination, and the findings have important implications for normal brain development, learning and cognition, and psychiatric disorders. Our research showing that myelination of axons by glia (oligodendrocytes and Schwann cells) is regulated by impulse activity provides evidence for a new form of nervous system plasticity and learning that would be particularly important in child development, given that myelination proceeds throughout childhood

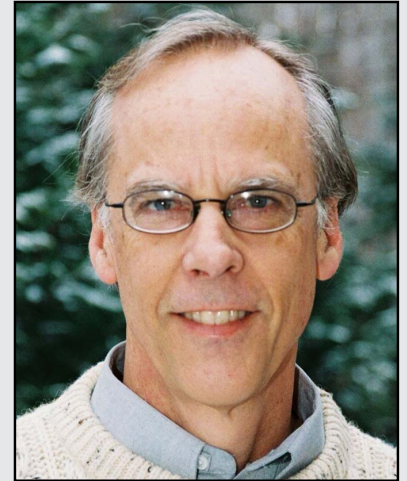

**R. Douglas Fields, PhD, Head,**  
*Section on Nervous System  
Development and Plasticity*

Philip Lee, PhD, *Staff Scientist*

Dipankar Dutta, PhD, *Visiting  
Fellow (Henry Jackson  
Foundation)*

Dong Ho Woo, PhD, *Visiting Fellow*  
William Huffman, MA, *Technician*

and adolescence. The mechanisms we identified suggest that environmental experience may alter myelin formation in an activity-dependent manner, thereby improving function based on experience.

Learning is perhaps the most important function of childhood. Our research is delineating the molecular mechanisms that convert short-term memory into long-term memory. While we continue our long-standing research on synaptic plasticity, our laboratory is actively exploring new mechanisms of nervous system plasticity during learning that extend beyond the neuron doctrine, such as neurons firing antidromically (backwards) and the release of neurotransmitters along axons. We are investigating how gene expression necessary for long-term memory is controlled and how intrinsic activity in the brain (oscillations and neuronal firing) forms memories. Our recent research showed that neurons in the hippocampus fire antidromically during sharp-wave ripple complexes, which are most frequent during slow-wave sleep, and that the firing reduces the strength of all synapses on that neuron (action potential-induced long-term depression or AP-LTD).

Information in the nervous system is encoded in the temporal pattern of action potential firing. If functional experiences produce lasting effects on brain development and plasticity, specific genes must be regulated by specific patterns of impulse firing. We verified the hypothesis and are determining how different patterns of neural impulses regulate specific genes controlling development and plasticity of the nervous system and how impulse activity affects neurons and glia.

## Regulation of myelination by neural impulse activity

Myelin, the multilayered membrane of insulation wrapped around nerve fibers (axons) by glial cells (oligodendrocytes), is essential for nervous system function, increasing conduction velocity at least 50-fold. Myelination is an essential part of brain development, but the processes controlling myelination of appropriate axons are not well understood. Myelination begins in late fetal life and continues throughout childhood and adolescence, but myelination of some brain regions is not complete until an individual's early twenties. Our research shows that neurotransmitters that are released along axons firing action potentials activate receptors on myelinating glia (Schwann cells in the peripheral nervous system and oligodendrocytes in the central nervous system) as well as astrocytes and other cells, which in turn release growth factors or cytokines that regulate development of myelinating glia.

### INDUCTION OF MYELINATION BY ACTION POTENTIALS

In addition to establishing the effects of impulse activity on proliferation and development of myelinating glia, we determined that release of the neurotransmitter glutamate from vesicles along axons promotes the initial events in myelin induction, including stimulating the formation of cholesterol-rich signaling domains between oligodendrocytes and axons and increasing the local synthesis of myelin basic protein, the major protein in the myelin sheath, through Fyn kinase-dependent signaling. Axon-oligodendrocyte signaling would thus promote myelination of electrically active axons to regulate neural development and neural function according to environmental experience. The findings are also relevant to such demyelinating disorders as multiple sclerosis and to remyelination after axon injury.

### SYNAPTIC AND NONSYNAPTIC TRANSMISSION IN MYELINATION

The surprising discovery of synapses formed on glial progenitors—oligodendrocyte progenitor cells (OPCs, also called NG2 cells)—has remained enigmatic for over a decade. The cells mature to form myelin insulation



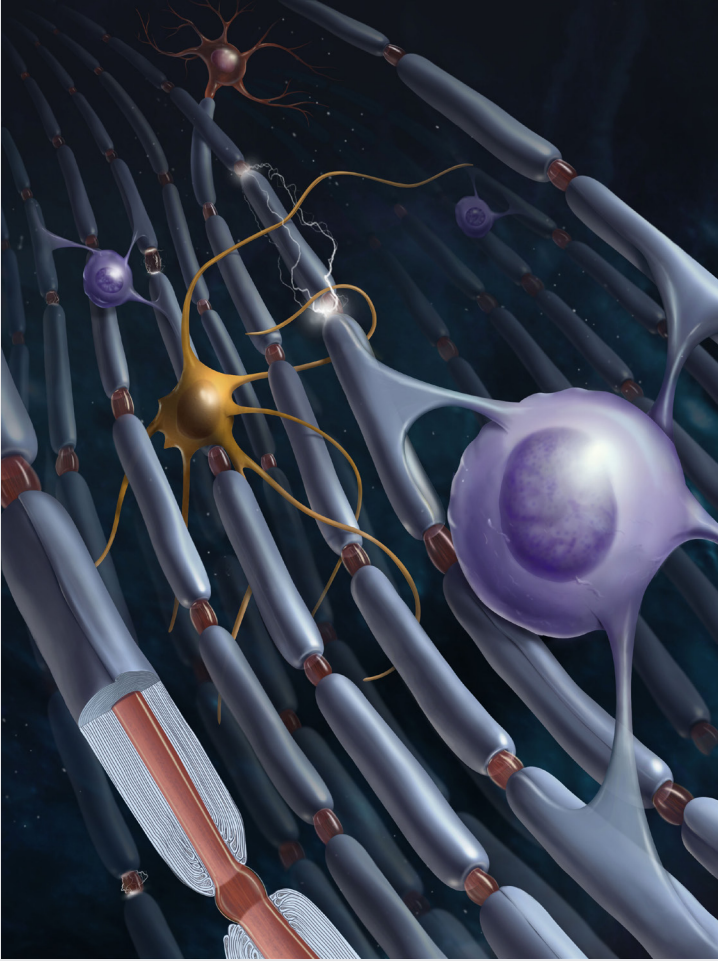

FIGURE 1. MYELIN

on axons, and a leading hypothesis is that these synapses may stimulate myelination selectively on electrically active axons, which would have significant effects on neural function, given that myelin increases the speed of impulse transmission. Using an *in vitro* system, we found that oligodendrocytes preferentially myelinate electrically active axons but that synapses from axons onto myelin-forming oligodendroglial cells are not required. Instead, vesicular release at non-synaptic axo-glial junctions induces myelination. Axon release of neurotransmitter from vesicles that accumulate in axon varicosities induces a local rise in cytoplasmic calcium in glial cell processes at such nonsynaptic functional junctions, and this signaling stimulates local translation of myelin basic protein to initiate myelination. As mentioned above, preferential myelin induction on electrically active axons would have profound effects on circuit function by increasing conduction velocity and would thus provide another

mechanism of plasticity complementing synaptic plasticity. These new findings may also have implications for disease, including psychiatric illness and impaired remyelination after conduction block in multiple sclerosis and other demyelinating disorders.

### MYELIN IN ACTIVITY-DEPENDENT PLASTICITY

Although the significance of myelin has been traditionally viewed in terms of conduction failure and spike-time arrival in determining synaptic function and plasticity, we are exploring how myelination affects the frequency, phase, and amplitude coupling of oscillations in the brain, as well as the propagation of brain waves. Abnormalities in brain waves and synchrony are associated with many psychiatric and developmental conditions, including, among others, schizophrenia, epilepsy, dyslexia, and autism.

### GULF WAR ILLNESS

After decades of research there is still no understanding of how a large group of Gulf War veterans became chronically ill with Gulf War Illness. It is believed that exposure to low levels of sarin nerve gas and combinations of organophosphate insecticides, which impair synaptic function, may be responsible.

Our recent discovery that glutamatergic transmission between axons and oligodendrocytes triggers myelination led us to propose that impairments in myelination due to disrupted neurotransmission from axons to oligodendrocytes may be an underlying cause of Gulf War Illness. Funded in part by a grant from the Department of Defense, we are investigating this hypothesis as part of an international consortium of researchers studying Gulf War Illness, headed by Kimberly Sullivan.

### MYELIN DAMAGE IN CHILDREN EXPOSED TO PESTICIDES

Children are uniquely vulnerable to uptake of pesticides, which act chemically through the same mechanism as nerve gas. Exposure, through ingestion and inhalation, is higher than for adults because of their greater intake of food and fluids per pound of body weight. In 2003, FDA monitoring determined that 49% of fruit, 29% of vegetables, and 26% of grain products produced in the United States have pesticide residue. The concentrations of pesticides in imported fruits and vegetables are higher, and 5–7% of imported foods with pesticide residue have levels of contamination above the legal tolerance limit for consumption. Fetal development is compromised by parental and maternal exposure to organophosphate pesticides. The neuro-developmental effects are well documented; they include developmental delay, lower IQ, and ADHD. Our research is thus exploring the possible involvement of myelin damage in the adverse developmental effects of pesticides on children.

## Synaptic plasticity

It is widely appreciated that there are two types of memory: short-term and long-term, and that sleep has a critical role in memory consolidation. Gene expression is necessary to convert short-term into long-term memory, but it is not known how signals reach the nucleus to initiate this process or what genes control strengthening and weakening of synapses in association with learning. Long-term potentiation (LTP) and long-term depression (LTD) are two widely studied forms of synaptic plasticity that can be recorded electrophysiologically in the hippocampus and are believed to represent a cellular basis for memory. We use electrophysiology and cDNA microarrays to investigate the signaling pathways, genes, and proteins involved in LTP and LTD. The work is contributing to a better understanding of how regulatory networks are controlled by the appropriate patterns of impulses, leading to different forms of synaptic plasticity, and is identifying new molecular mechanisms regulating synaptic strength.

Homeostatic controls are required to prevent a neural network from becoming incapacitated, and sleep is thought to be an important period for LTD and dendritic remodeling in memory consolidation. Although most studies of learning and memory use sensory stimulation, intrinsic activity in the brain, in particular oscillatory firing at different characteristic frequencies, is critical in information processing and learning. The brain's intrinsic activity includes many non-traditional modes of neuronal firing. In the hippocampus high-frequency oscillations affect synaptic plasticity in the process of memory consolidation during slow-wave sleep and periods of quiet wakefulness. During these periods, neural sequences learned while encoding sensory information are replayed, and CA1 neurons in the hippocampus fire antidromically in brief high-frequency oscillations called sharp-wave ripple complexes. Action potential firing during sharp-wave ripple complexes is initiated in the distal axon and propagates back into the cell body and dendrites. Our studies show that such antidromic firing reduces the strength of all synaptic inputs to the neuron (AP-LTD) and that the synapses then become sensitized to strengthening by subsequent sensory input. The process of globally reducing synaptic strength participates in the formation of transiently stable functional assemblies of neurons and is necessary for incorporating new information together with existing memories to form a schema, or coherent memory,

combining multiple sensations and temporal sequence into a cognitive framework.

The neurotrophin, brain-derived neurotrophic factor (BDNF) has been implicated in many forms of synaptic plasticity, nervous system development, and nervous system disorders. Our research shows that a rapid and persistent down-regulation of different mRNA transcripts of the *BDNF* gene accompanies AP-LTD. Moreover, AP-LTD is abolished in mice with the *Bdnf* gene knocked out in CA1 hippocampal neurons. Homeostatic controls are required to prevent a neural network from becoming incapacitated, and sleep is thought to be an important period for LTD and dendritic remodeling in memory consolidation. Given the well established role of this neurotrophin in increasing synaptic strength, promoting synaptogenesis and dendritic complexity, the rapid reduction of *BDNF* mRNA during AP-LTD could contribute to reducing synaptic strength during AP-LTD and promote synaptic remodeling.

## Regulation of gene expression by action-potential firing patterns

To determine how gene expression in neurons and glia is regulated by impulse firing, we stimulate nerve cells to fire impulses in differing patterns by delivering electrical stimulation through platinum electrodes in specially designed cell culture dishes. After stimulation, we measured mRNA and protein expression by gene arrays, quantitative RT-PCR (reverse transcriptase-polymerase chain reaction), RNAseq, microarray, Western blot, and immunocytochemistry. The results confirm our hypothesis that precise patterns of impulse activity can increase or reduce expression of specific genes (in neurons and glia). The experiments are revealing signaling and gene-regulatory networks that respond selectively to appropriate temporal patterns of action potential firing. Temporal aspects of intracellular calcium signaling are particularly important in regulating gene expression according to neural impulse firing patterns in normal and pathological conditions. Our findings thus provide a deeper understanding of how nervous system development and plasticity are regulated by information coded in the temporal pattern of impulse firing in the brain. The findings are also relevant to chronic pain as well as to the regulation of nervous system development and myelination by functional activity.

In collaboration with David Clark, we are investigating chromatin structure and remodeling in neurons and glia. This research is supported in part by a NICHD DIR Director's award jointly to Drs. Clark and Fields.

## Additional Funding

- DOD Grant: 2012, Gulf War Illness Research Program Consortium Award, CDMRP Number: GW120037, Project Duration: 48 months
- NICHD DIR Director's award

## Publications

1. Wake H, Ortiz FC, Woo DH, Lee PR, Angulo MC, Fields RD. Nonsynaptic junctions on myelinating glia promote preferential myelination of electrically active axons. *Nat Commun* 2015 6:7844.
2. Fields RD. A new mechanism of nervous system plasticity: activity-dependent myelination. *Nat Rev Neurosci* 2015 16(12):756-767.
3. Filley CM, Fields RD. White matter and cognition: making the connection. *J Neurophysiol* 2016; E-pub ahead of print.

4. Bukalo O, Lee PR, Fields RD. BDNF mRNA abundance regulated by antidromic action potentials and AP-LTD in hippocampus. *Neurosci Lett* 2016; E-pub ahead of print.
5. Ravin R, Blank PS, Busse B, Ravin N, Vira S, Bezrukov L, Waters H, Guerrero-Cazares H, Quinones-Hinojosa A, Lee PR, Fields RD, Bezrukov SM, Zimmerberg J. Blast shockwaves propagate Ca(2+) activity via purinergic astrocyte networks in human central nervous system cells. *Sci Rep* 2016 6:25713.

## Collaborators

- Maria Cecilia Angulo, PhD, *INSERM, Université Paris Descartes, Paris, France*
- Peter J. Basser, PhD, *Section on Quantitative Imaging and Tissue Sciences, NICHD, Bethesda, MD*
- David Clark, PhD, *Section on Chromatin and Gene Expression, NICHD, Bethesda, MD*
- Fernando Ortiz, PhD, *Université René Descartes, Paris, France*
- Rea Raven, PhD, *Intramural Research Programs, NIBIB, Bethesda, MD*
- Pajevic Sinisa, PhD, *Division of Computational Bioscience, Center for Information Technology, NIH, Bethesda, MD*
- Kimberly Sullivan, PhD, *Boston University School of Public Health, Boston, MA*
- Hiroaki Wake, PhD, *National Institute for Basic Biology, Okazaki, Japan*
- Joshua Zimmerberg, MD, PhD, *Section on Cellular and Membrane Biophysics, NICHD, Bethesda, MD*

## Contact

For more information, email [fieldsd@mail.nih.gov](mailto:fieldsd@mail.nih.gov) or visit <http://nsdps.nichd.nih.gov>.

## Quantitative Biophotonics for Tissue Characterization and Function

Our general goal is to devise quantitative methodologies and associated instrumentation to bring technologies from the bench to bedside. We select our projects in the framework of the mission of the NICHD, focusing on childhood and adolescent disorders, as well as abnormal developments of cells such as occur in cancer. We operate in the so-called 4B research mode: (1) at the Blackboard—modeling the methodologies, (2) at the Bench—designing the prototypes to be brought to the Bedside, (3) at the Bedside—piloting clinical protocols, and (4) Back to the BlackBoard—improving the systems/methodologies.

### Structural and functional brain imaging

Functional near-infrared spectroscopy (fNIRS) is an emerging non-invasive imaging technique to assess brain function. The technique is portable and therefore applicable in studies of children and toddlers, especially those with neuro-developmental disorders. fNIRS measurements are based on the local changes in cerebral hemodynamic levels (oxy-hemoglobin and deoxy-hemoglobin) associated with brain activity, similar to BOLD (blood-oxygen-level dependent contrast imaging) fMRI. Given the low optical absorption of biological tissues at near infrared (NIR) wavelengths (700–900 nm), NIR light can penetrate deep enough to probe cortical regions up to 1–3 cm deep. Furthermore, the NIR absorption spectrum (NIRS) of the tissue is sensitive to changes in the concentration of major tissue chromophores such as hemoglobin, so that measurements of temporal variations of backscattered light can capture functionally evoked changes in the outermost cortex and used to assess the brain function. However, there is a need to address the changes in NIRS signal related to underlying physiological processes in the brain such as cerebral autoregulation (CA). In short, CA maintains blood flow over the range of arterial blood pressure and, owing to the high metabolic demand of neurons, becomes a vital process for a brain function. Devising a novel method of data processing to enrich the informational content of measured characteristics from fNIRS is therefore crucial for further studies of brain function and development.

In a pilot study, we evaluated the utility of fNIRS in measuring



**Amir H. Gandjbakhche, PhD,**  
*Head, Section on Analytical and  
Functional Biophotonics*

Victor Chernomordik, PhD, *Staff  
Scientist*

Fatima A. Chowdhry, MD,  
*Research Fellow*

Afrouz Anderson, PhD,  
*Postdoctoral Fellow*

Elizabeth Smith, PhD, *Postdoctoral  
Fellow*

Nader Shahni Karamzadeh, PhD,  
*Data Scientist (Contractor)*

Ali Afshari, MS, *Predoctoral  
Student*

Hadis Dashtestani, MS,  
*Predocctoral Student*

Riley Kermanian, BS,  
*Postbaccalaureate Fellow*

Rachel Zaragoza, BS,  
*Postbaccalaureate Fellow*

Maryam Ghasemi Ghonchehnazi,  
MSc, *Special Volunteer*

Elahe Shafiei Haghshenas, MSc,  
*Special Volunteer*

Franck Amyot, PhD, *Guest  
Researcher*

Siamak Aram, PhD, *Guest  
Researcher*

Yasaman Ardeshirpour, PhD,  
*Guest Researcher*

Bahar Dasgeb, MD, *Guest  
Researcher*

Jana Kainerstorfer, PhD, *Guest  
Researcher*

FIGURE 1.

(A) OV index values from left and right prefrontal cortex in TD and AR subjects with TD subjects exhibiting a higher OV index. The error bar is based on the standard deviation. (B) Percent difference between left and right activation for each subject. Negative values indicate right lateralization while positive values show left lateralization. Higher values in the positive and negative direction indicate the greater activation in left or right PFC, respectively.

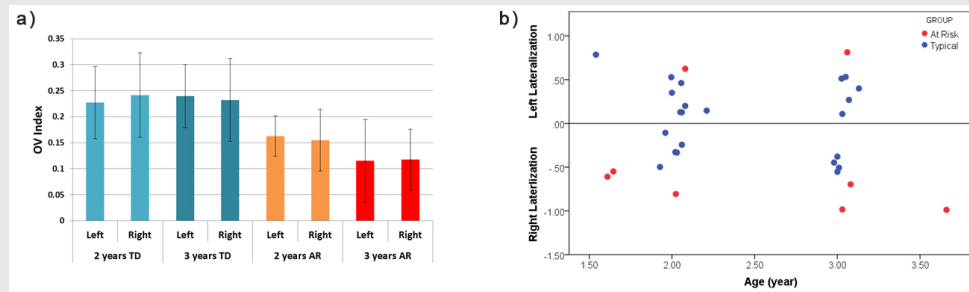

cerebral hemodynamics in the prefrontal cortex (PFC) in toddlers between 18 and 36 months of age. Further, we analyzed group differences in fNIRS data gathered during a 'vanilla' baseline period (such as watching a calming video) in toddlers with typical development delay and a group of children at risk for developmental delay. The analysis includes assessment of the hemodynamic activation, based on changes in oxy-hemoglobin, in the left and right PFC, and the oxygenation variability (OV) index based on variability in oxygen saturation at frequencies attributed to CA for each child. In our pilot study we found that at-risk (AR) participants showed preliminary evidence for both more right-sided activation and higher differences between left and right activation than in the typical development (TD) group (Figure 1B). In addition, AR toddlers had a significantly lower overall OV index than TD children in both the left and right PFC (Figure 1A). It is worth mentioning that the OV index is not a direct measure of CA. Rather, the OV index is associated with frequencies related to this mechanism and serves to quantify oscillations in those frequencies. While this study suggests that some features of prefrontal hemodynamics may vary in toddlers at risk for developmental delays owing to early language delay, more research in this age group is required to clarify the specificity of these differences. These preliminary findings show the feasibility of using fNIRS in typical toddlers and those with delayed development and in doing so support future studies in larger samples.

In another study involving a group of healthy controls (HC) and a traumatic brain injury (TBI) population, low frequency oscillations in the hemodynamic signal were assessed using the OV Index, which were obtained from the oxy/deoxy-hemoglobin variations in response to an action complexity judgment task. The task produced a varying cognitive load that led to activation of the brain, more so the anterior and medial region than the dorsolateral prefrontal cortex. These regions in the brain show a more intense hemodynamic response during a working memory task. The HC and the TBI group had to evaluate the complexity of daily life activities by classifying the number of steps within the task as being "few" or "many," which are further divided into high and low complexity tasks. Within the HC group, there was a strong parametric effect with regard to the mean OV indices that corresponded to the high complexity tasks, which were higher than that of the low complexity tasks. We computed the ratio of OV indices for high complexity and low complexity loads for each subject. Our results show that this ratio is significantly higher for the HC group than for the TBI group. This means that, for the TBI group, brain activation does not change significantly between high- and low-complexity loads, in contrast to the HC group, and shows that OV index metrics can be sensitive when applied to chronic TBI and potentially used to separate subpopulations of TBI from HC (Figure 2).

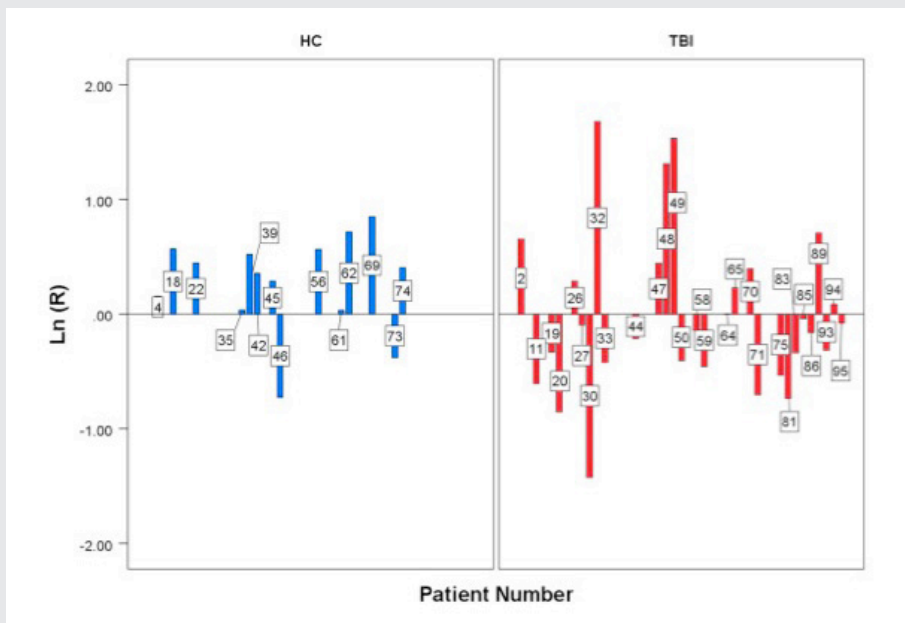

**FIGURE 2.**

Individual subject ratio (R), on a logarithm scale, of the OV indexes between high- and low-complexity load tasks in 14 HC (healthy control) patients (blue) and 29 traumatic brain injury (TBI) patients (red). The ratio for each individual shows an increase of OV index in the HC group between the two loads but not in the TBI group.

Moreover, we explored the potential prefrontal hemodynamic biomarkers to characterize subjects with TBI by employing a multivariate machine-learning approach and introducing a novel task-related hemodynamic response detection followed by a heuristic search for optimum set of hemodynamic features. To achieve this goal, the hemodynamic response from a group of 31 healthy controls and 30 chronic TBI subjects were recorded as they performed a complexity task. To determine the optimum hemodynamic features, we considered 11 features and their combinations in characterizing TBI subjects. We investigated the significance of the features by using a machine-learning classification algorithm to score all the possible combinations of features according to their predictive power. The identified optimum feature elements resulted in classification accuracy, sensitivity, and specificity of 85%, 85%, and 84%, respectively. Classification improvement was achieved for TBI subject classification through feature combination. It signified the major advantage of the multivariate analysis over the commonly used univariate analysis, suggesting that the features that are individually irrelevant in characterizing the data may become relevant when used in combination. We also conducted a spatio-temporal classification to identify regions within the PFC that contribute to distinguishing between TBI and healthy subjects. As expected, Brodmann area 10 (BA10) within the PFC was the only region in which healthy subjects, unlike subjects with TBI, showed major hemodynamic activity in response to the High Complexity task. Overall, our results indicate that identified temporal and spatio-temporal features from PFC's hemodynamic activity are promising biomarkers in classifying subjects with TBI (Figure 3).

## Multispectral imaging

Facial plethora is one of the earliest described clinical features of Cushing's syndrome (CS). In collaboration with the Section on Genetics and Endocrinology, we continued a study aimed at quantifying changes of facial plethora in CS as an early assessment of treatment efficacy. Cushing's patients are recruited for multi-spectral imaging, before and after surgery with follow-up sessions 6 months to two years after surgery. To

**FIGURE 3. Average activity maps for the CSL and HV features for the healthy (a) and TBI (b) subjects**

The activity map for a spatio-temporal feature associated with a population is obtained by averaging every subject's (from the corresponding population) spatio-temporal feature set. For the TBI population, the larger HbO variance (HV) values are located at several locations, with largest on the right hemisphere, whereas for the healthy population the largest HV is concentrated on the left hemisphere of Brodmann area 10 (BA10). Furthermore, on average healthy subjects show larger HV values for the HbO signal, which indicates that the oxygenation signal shows higher variation in the healthy subjects. The HbO signal in response to the high-complexity task for the healthy subjects shows larger variation and is spatially less diffuse than for the TBI subjects. Larger activity CSL (curve slope left) values correspond to a faster rate of oxygenation consumption.

Considering the activity map for healthy subjects, the largest CSL values cover the left frontopolar of the BA10. A comparison of healthy and TBI subjects' CSL activity map reveals that healthy subjects show higher oxygenation consumption rate in response to the high-complexity task at all the sites of fNIRS data collection.

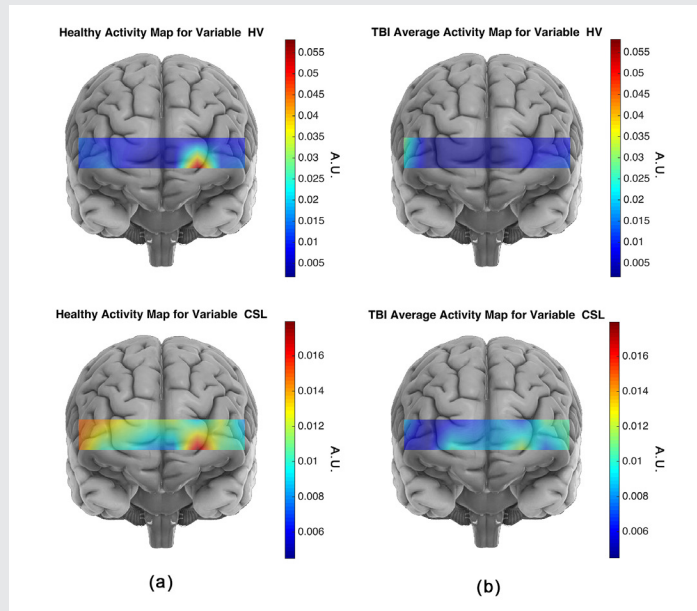

date, of the 69 subjects enrolled in our study, 57 were recognized to be eligible for the processing stage. Four required two consecutive surgeries, as the initial trans-sphenoidal surgery (TSS) was unsuccessful. So far, we were able to reconstruct the biological parameters of 61 subjects. Among these, 44 patients had adrenocorticotrophic hormone (ACTH)-secreting pituitary tumors-Cushing's disease (CD), 14 had ACTH-independent adrenocortical tumors and three had an ectopic ACTH-secreting pulmonary carcinoid. Non-invasive multi-spectral near-infrared imaging was performed on the right cheek of the patients before and two days or up to two weeks after surgery. Patients were defined as cured by post-operative plasma cortisol of less than 3 mcg/dl and/or adrenocortical insufficiency for which they received replacement. Clinical data, obtained from the 57 patients, indicate that a decrease in facial plethora after surgery, as evidenced by decrease in blood volume fraction, is well correlated with cure of CS (Reference 3).

We recently explored the same trend by studying the water content fraction. Our new finding shows that water content fraction could also quantify facial plethora as a biomarker of early cure in patients with CS. We observed that the fraction of the cheek's water content, measured with the multi-spectral system, could be used to differentiate cured and non-cured CS patients within a short time after surgical treatment (Figure 4). The findings for both blood volume and water content fractions are significantly correlated, but it seems blood volume is better associated with clinical evaluations. The number of false-negatives in water content analysis was slightly higher. Application of this novel technology in follow up data was realized and we obtained successful results; the methodology and analytic algorithm is applied during the first and second post-surgery follow up. First follow up is usually between 3-6 months after surgery and second follow six months after first follow up. We have processed data for 22 imaged patients in first follow up and 10 in



FIGURE 4.

A. Facial plethora in a patient with CD before trans-sphenoidal surgery (TSS), after the first TSS (non-cured), and after the second TSS (cured).

B. The blood volume fraction percentage change of the patient's right cheek associated with Figure A at different imaging sessions underscores the advantage of the method over visual inspection.

C. Boxplot of medium percentage change indicating change in blood volume after surgery, compared with before surgery, in each of the remission and non-responding groups of Cushing's patients. The distribution shows median confidence interval box and interquartile range.

D. Correlation of percentage change in blood volume and water content fractions of right cheek side of 57 CD patients who received surgical treatment.

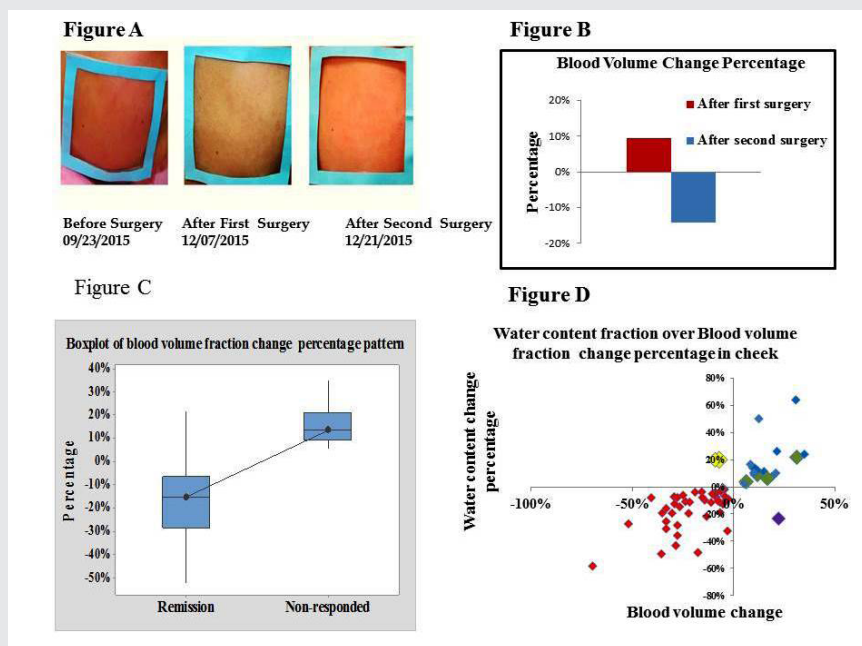

second follow up. They were identified clinically in remission state by last visit. The results confirmed our hypothesis that patients who were assessed as cured, based on significant drop in their cortisol level after the surgery, retained a lower blood volume fraction in the region of interest than before surgical treatment, also in follow up sessions. The next step is to develop an improved multi-spectral system for CS that will consist of imaging capabilities at several wavelengths.

We are pursuing Kaposi Sarcoma (KS) studies in ongoing clinical trials under four different NCI protocols and therapeutic agents. We observed additional patients and will apply a new classification system in the processing stage that will result in a proof of capability of our novel technology as a robust device and additional tool for the medical community. In ongoing analyses of the data, the goal is to further evaluate diffuse multi-spectral imaging in a relatively large sample as a potential supplement to existing response assessment in KS, providing an early non-invasive marker of treatment efficacy.

## Fluorescence methods in pre-clinical studies of HER2-positive breast cancer and of basal cell carcinoma expressing BerEP4

**HER2-specific fluorescently labeled probes:** We studied the potential of *in vivo* fluorescence lifetime imaging to monitor the efficacy of treatment, in particular the feasibility of fluorescence lifetime imaging to monitor *in vivo* expression of the HER2 receptor in a breast carcinoma (mouse model) during the course of treatment. We observed a considerable difference between the fluorescence lifetime of HER2-specific optical probes at the tumor and a contra-lateral site before and seven days after the last treatment with 17-DMAG (an HSP90 inhibitor), when the tumor regrew to almost its pretreatment volume. However, soon after the



FIGURE 5.

Left panels. NIRS device and its schematic for placenta oxygenation measurement. Right panel. The device allows probing of different placental/maternal tissue depth.

therapy (12 hours), when the effect of drug on HER2 degradation is maximal, the difference was significantly smaller. Based on our previous findings on the relationship between fluorescence lifetime and binding of a HER2-specific probe to corresponding receptors, we believe that the differences between the fluorescence lifetimes at the tumor and contralateral site, observed for mice with BT-474 xenografts after treatment with 17-DMAG, results from the strong downregulation of HER2 receptors soon after the therapy (i.e., fewer binding sites for the HER2-specific probe) and corresponding changes in the fraction of bound to total fluorescent probes in the tumor. Immediately after treatment, the fraction of bound to total fluorophores inside the tumor changed considerably, resulting in a noticeable increase in the average fluorescence lifetime. Subsequent tumor and HER2 expression recovery a week later caused gradual restoration of the original level of the binding ratio of HER2-targeting probe in the tumor and a corresponding return to pre-treatment values of the fluorescence lifetime. The results reveal that fluorescence lifetime imaging, based on evaluating the fraction of the bound and unbound fluorophores inside the tumor, can be used as an alternative *in vivo* imaging approach to characterize tumors, separate high from low HER2-expression tumors, and monitor the efficacy of targeted therapies.

***Molecular biomarkers for basal cell carcinoma (BCC) for use in its diagnosis, treatment, and follow up:***

We conducted a pilot study to determine the affinity and selectivity of the BerEp4 antibody conjugated with a fluorescence probe and to assess its possible use in designing theranostic probes for BCC. BCC appears macroscopically and microscopically similar to many other skin lesions, which makes differential diagnosis difficult. Based on initial cell culture results, BerEP4 appears to be a promising biomarker for molecular imaging of BCC and can be used in conjunction with *in vivo* near-infrared fluorescence imaging. To prepare BerEP4 for eventual theranostic use, we examined the feasibility of a combined macro-/micro-optical approach to imaging BCC with various histologies. During an *in vitro* phase, we showed specificity and selectivity of the BerEP4 antibody to target EpCAM on live cells. EpCAM is an ideal biomarker to target BCC because it is expressed in more than 95% of human BCC. In the subsequent *in vivo* phase, using xenograft mouse models, we reproduced persisting *in vivo* specificity and selectivity of the BerEP4 antibody to detect EpCAM-expressing xenograft tumors, when injected systemically via tail veins. Moving forward, we plan to: (1) modify our antibody to a smaller molecule—a stable aptamer or single-strand antibody—to facilitate topical delivery (instead of systemic) for skin cancer; (2) repeat the *in vivo* experiment to show reproducible results with modified and smaller probe; this phase would encompass initial systemic injection of the probe

followed by experiments to test how best to achieve topical delivery, including micro-injection; (3) once *in vivo* non-invasive targeting of BCC is achieved via topical introduction, to further engineer our diagnostic probe to be photo-sensitized to achieve photodynamic treatment at the time of diagnosis.

## Real-time oximetry of anterior placenta using near infrared spectroscopy

Monitoring placental oxygenation and the vascular network binding the expectant mother to the fetus is critical to ensure a healthy pregnancy outcome. In the third conference on the Human Placenta Project held at NIH in April, 2016, it was acknowledged that the quantification of placental oxygenation could play a vital role in both maternal and fetal health during pregnancy. Reduced utero-placental perfusion has been associated with preeclampsia and intrauterine growth restriction, and reduced oxygenation can lead to fetal hypoxia, asphyxia, and cerebral palsy. However, there are instances where higher oxygenation at the intervillous space during pregnancy has been associated with abnormal placental function. But there are no patient-friendly devices to measure the oxygenation of the placenta. One of the challenges identified at the conference was the lack of a baseline for normal placental oxygenation. Therefore, it is of fundamental importance to have a quantitative understanding of placental oxygenation to detect any abnormality (i.e., increase or decrease) relative to normal placental function. With its wearable, wireless capability convenient for dynamic monitoring, fNIRS provides a technique that can address these challenges. Through the Human Placenta Project, we intend to (1) find the baseline for the normal vs. abnormal pregnancies and standardize the oxygenation data across pregnancies and (2) correlate the oxygenation data with the pregnancy outcomes.

We have accomplished the first critical phase of this project at the bench. We now have a fast, non-invasive, wearable device with wireless capability that allow continuous measurement of the oxygenation of the anterior placenta in a subject-friendly environment. This compact system, only weighting 1.4 ounces, can be positioned at different abdominal locations for efficient and localized measurement of oxygenation. In detail, the device consists of two detectors and three sources (Figure 5). Given that the probing depth of NIRS depends on the source detector separation, we devised the system to interrogate at different depths. This would provide us with information about different tissue types and permit us to distinguish between maternal and placental tissue. The NIRS device uses light in the near-infrared region at two wavelengths (760 and 850 nm), which are sensitive to changes in oxy-hemoglobin and deoxy-hemoglobin. Light enters the tissue at the location of source, and back scattered light is detected at the detector site. For patient safety, light intensities are within FDA requirements for Class I devices (less than 100 mW). The multiple-source detector design will allow probing of different vascular compartments of the uterus. By adding frequency filtering related to the pulsation of maternal tissue, we expect to separate the hemodynamics of the placenta from that of maternal tissue.

Using a similar approach, we were able to create a new index, the oxygenation variability index (OVI), which is correlated with CA. The index can be seen as the coefficient of variation of instantaneous oxygen saturation in frequency band directly related to the blood autoregulation. The pertinence of this quantitative parameter has been tested in brain activation in children (age 4-8). We tested the performance of the device on a static phantom that mimics the optical properties of uterine and placental tissue. The first layer (shallower region, thickness of 1cm) was designed to have very low absorption, whereas the second layer (deeper region, thickness of 3 cm) had much higher absorption. Using the device, we were able to distinguish between the layers and interrogate at different depth levels. Figure 6 shows an example of the initial analysis on our

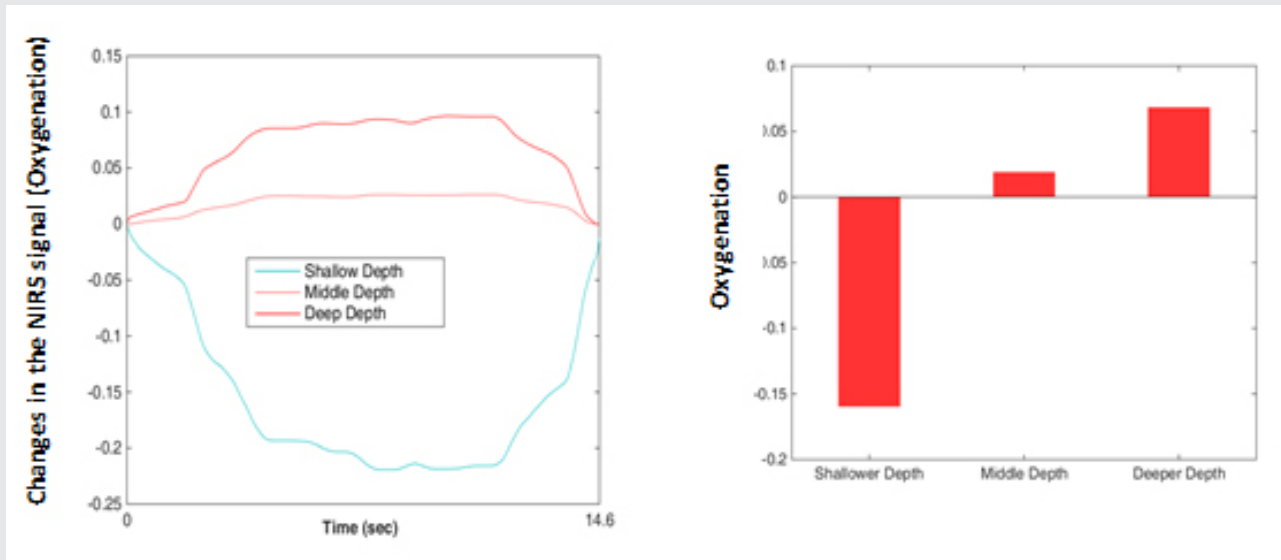

FIGURE 6.

Oxygenation measurement using a two-layer phantom, simulating maternal and placental tissue.

prototype phantom, where the deeper layer shows higher oxygenation than the shallower regions.

Our general strategy is to monitor the oxygenation of the placenta dynamically. Therefore we propose to use state-of-the-art 3D printing to simulate a dynamic placenta model. The 3D model will mimic both structural and functional aspects of the placenta and maternal tissue and provide more in-depth analysis of the NIRS signal regarding the changes in oxygenation of the placenta. Shad Deering will guide us in our clinical studies. Through this collaboration, we expect to test our device through a clinical protocol for a pilot study. Being able to separate maternal tissue oxygenation from placental oxygenation involves refining our data analysis software by incorporating anatomical localization and standardizing it across pregnancy. The outcome of this study might help provide earlier detection of pregnancy complications and thus improve both maternal and fetal health.

## Additional Funding

- Bench to Bedside Award 345 (2016): "Mirror neuron network dysfunction as an early biomarker of neurodevelopment" (ongoing)
- Human Placenta Project-NICHD (2016) (ongoing)

## Publications

1. Karamzadeh N, Amyot F, Kenney K, Anderson A, Chowdhry F, Dashtestani H, Wassermann EM, Chernomordik V, Boccara C, Wegman E, Diaz-Arrastia R, Gandjbakhche AH. A machine learning approach to identify functional biomarkers in human prefrontal cortex for individuals with traumatic brain injury

- using functional near-infrared spectroscopy. *Brain Behav* 2016 1-14.
2. Chernomordik V, Amyot F, Kenney K, Wassermann E, Diaz-Arrastia R, Gandjbakhche A. Abnormality of low frequency cerebral hemodynamics oscillations in TBI population. *Brain Res* 2016 1639:194-199.
  3. Afshari A, Ardeshirpour Y, Lodish MB, Gourgari E, Sinai N, Keil M, Belyavskaya E, Lyssikatos C, Chowdhry FA, Chernomordik V, Anderson AA, Mazzuchi TA, Gandjbakhche A, Stratakis CA. Facial plethora: modern technology for quantifying an ancient clinical sign and its use in Cushing syndrome. *J Clin Endocrinol Metab* 2015 3928-3933.
  4. Karamzadeh N, Ardeshirpour Y, Kellman M, Chowdhry F, Anderson A, Chorlian D, Wegman E, Gandjbakhche A. Relative brain signature: a population-based feature extraction procedure to identify functional biomarkers in the brain of alcoholics. *Brain Behav* 2015 e00335.
  5. Amyot F, Arciniegas DB, Brazaitis MP, Curley KC, Diaz-Arrastia R, Gandjbakhche A, Herscovitch P, Hinds SR 2nd, Manley GT, Pacifico A, Razumovsky A, Riley J, Salzer W, Shih R, Smirniotopoulos JG, Stocker D. A review of the effectiveness of neuroimaging modalities for the detection of traumatic brain injury. *J Neurotrauma* 2015 32(22):1693-1721.

## Collaborators

- Samuel Achilefu, PhD, *Washington University School of Medicine, St. Louis, MO*
- Claude Boccara, PhD, *École Supérieure de Physique et de Chimie Industrielles, Paris, France*
- Shad Deering, MD, *Uniformed Services University of the Health Sciences, Bethesda, MD*
- Stavros Demos, PhD, *Lawrence Livermore National Laboratory, Livermore, CA*
- Ramon Diaz-Arrastia, MD, PhD, *Center for Neuroscience and Regenerative Medicine, Uniformed Services University of the Health Sciences, Bethesda, MD*
- Israel Gannot, PhD, *Tel Aviv University, Tel Aviv, Israel, and The George Washington University, Washington, DC*
- Jay Knutson, PhD, *Laboratory of Molecular Biophysics, NHLBI, Bethesda, MD*
- Maya Lodish, MD, *Pediatric Endocrinology Training Program, NICHD, Bethesda, MD*
- Tom Pohida, MS, *Division of Computational Bioscience, Center for Information Technology, NIH, Bethesda, MD*
- Randall Pursley, *Signal Processing and Instrumentation Section, Center for Information Technology, NIH, Bethesda, MD*
- Dan Sackett, PhD, *Section on Cell Biophysics, NICHD, Bethesda, MD*
- Babak Shadgan, MD, MSc, PhD, *University of British Columbia, Vancouver, Canada*
- Constantine Stratakis, MD, D(med)Sci, *Section on Endocrinology and Genetics, NICHD, Bethesda, MD*
- Audrey Thurm, PhD, *Pediatrics & Developmental Neuropsychiatry Branch, NIMH, Bethesda, MD*
- Eric Wassermann, MD, *Cognitive Neuroscience Section, NINDS, Bethesda, MD*
- Robert Yarchoan, MD, *HIV and AIDS Malignancy Branch, NCI, Bethesda, MD*

## Contact

For more information, email [amir@helix.nih.gov](mailto:amir@helix.nih.gov) or visit <http://safb.nichd.nih.gov>.

## Transcriptional and Translational Regulatory Mechanisms in Nutrient Control of Gene Expression

We study the fundamental mechanisms involved in the assembly and function of translation initiation complexes for protein synthesis, using yeast as a model system to exploit its powerful combination of genetics and biochemistry. The translation initiation pathway produces an 80S ribosome bound to mRNA with methionyl initiator tRNA (tRNA<sup>i</sup>) base-paired to the AUG start codon. The tRNA<sup>i</sup> is recruited to the small (40S) subunit in a ternary complex (TC) with GTP-bound eIF2 to produce the 43S preinitiation complex (PIC) in a reaction stimulated by eIFs 1, 1A, 3, and 5. The 43S PIC attaches to the 5' end of mRNA, facilitated by cap-binding complex eIF4F (comprising eIF4E, eIF4G, and the RNA helicase eIF4A) and poly(A)-binding protein (PABP) bound to the poly(A) tail, and scans the 5' untranslated region (UTR) for the AUG start codon. Scanning is promoted by eIFs 1 and 1A, which induce an open conformation of the 40S and rapid TC binding in a conformation suitable for scanning successive triplets entering the ribosomal P site (P-out), and by eIF4F and other RNA helicases, such as Ded1, that remove secondary structure in the 5' UTR. AUG recognition evokes tighter binding of TC in the P-in state and irreversible GTP hydrolysis by eIF2, dependent on the GTPase-activating protein (GAP) eIF5, releasing eIF2-GDP from the PIC with tRNA<sup>i</sup> remaining in the P site. Joining of the 60S subunit produces the 80S initiation complex ready for protein synthesis. Our current aims in this research area are to: 1) elucidate functions of eIF1, eIF1A, eIF2, and 40S proteins in TC recruitment and start codon recognition; 2) identify functions of eIF4G, eIF4B/Tif3, and Ded1 in mRNA activation, 48S PIC assembly, and scanning *in vivo*; 3) uncover the mechanisms of translational repression by Scd6, Pat1, Dhh1 and Khd1; and 4) elucidate the mechanism of ribosome recycling at stop codons *in vivo*.

We also analyze the regulation of amino acid-biosynthetic genes in budding yeast as a means of dissecting fundamental mechanisms of transcriptional control of gene expression. Transcription of these genes is coordinately induced by the activator Gcn4 during amino acid limitation owing to induction of Gcn4 at the translational level. The eviction of nucleosomes that occlude promoter DNA sequences and block access by RNA polymerase is thought to be a rate-limiting step for transcriptional activation. Previous studies implicated certain histone chaperones, ATP-dependent chromatin



**Alan G. Hinnebusch, PhD, Head,**  
*Section on Nutrient Control of  
Gene Expression*

Hongfang Qiu, PhD, *Staff Scientist*

Neelam Sen, PhD, *Research Fellow*

Suna Gulay, PhD, *Postdoctoral  
Fellow*

Neha Gupta, PhD, *Postdoctoral  
Fellow*

Anil Thakur, PhD, *Postdoctoral  
Fellow*

Jyothsna Visweswaraiyah, PhD,  
*Postdoctoral Fellow*

Fnu Yashpal, PhD, *Postdoctoral  
Fellow*

David Young, PhD, *Postdoctoral  
Fellow*

Quira Zeiden, PhD, *Postdoctoral  
Fellow*

Jinsheng Dong, PhD, *Senior  
Research Assistant*

Fan Zhang, MS, *Senior Research  
Assistant*

Laura Marler, BS, *Graduate  
Student*

remodeling complexes, or histone acetyltransferase complexes in eviction of promoter nucleosomes at certain yeast genes, but it was unclear whether these co-factors function at Gcn4 target genes. Our current aim is to identify the full set of co-factors that participate in promoter nucleosome eviction at Gcn4 target genes, their involvement in this process genome-wide, and the transcriptional consequences of defective nucleosome eviction.

## Structures of yeast preinitiation complexes reveal conformational changes from mRNA scanning to start-codon recognition.

It is thought that the scanning PIC assumes an open conformation and that AUG recognition evokes a closed state that arrests scanning with more stable tRNA<sub>i</sub> binding (P-in state), with attendant displacement of the eIF1A-CTT (C-terminal tail) from the P site and dissociation of eIF1 from the 40S subunit. In collaboration with Venki Ramakrishnan's and Jon Lorsch's groups, we obtained cryo-EM reconstructions of yeast PICs that represent different stages of the initiation pathway, at 3.5–6.1 Å resolution. These include 40S-eIF1-eIF1A complexes and partial yeast 48S PICs in open and closed conformations (py48S-open and py48S-closed). The structures yield considerable new information about conformational changes in the transition from scanning to AUG selection. The py48S-open complex, formed using mRNA with AUC start codon, reveals an upward shift of the 40S head that widens the mRNA entry channel and opens its latch—consistent with our eIF1A/Fe(II)-BABE cleavage data—which should facilitate mRNA insertion into the binding cleft to form the scanning PIC. Moreover, the P site is widened and lacks tRNA<sub>i</sub> contacts with the 40S body present in canonical 80S-tRNA<sub>i</sub> complexes. Formed with mRNA(AUG), py48S-closed reveals downward head movement that closes the latch, clamps the mRNA into the binding cleft, and fully encloses tRNA<sub>i</sub> in the P site. The eIF1A N-terminal tail (NTT) interacts with the AUG:anticodon duplex, consistent with its role in stabilizing P-in. As a prelude to eIF1 dissociation from the 40S subunit, eIF1 is repositioned on the 40S and deformed to prevent a clash with tRNA<sub>i</sub>. Both py48S-open and -closed complexes reveal eIF2beta and portions of the eIF3 complex. The eIF3 trimeric subcomplex eIF3b-CTD/eIF3i/eIF3g-NTT resides on the subunit-interface surface of the 40S and appears to lock mRNA into the 40S binding cleft. Exclusively in py48S-open, eIF2beta interacts with tRNA<sub>i</sub> and segments of eIF1 and eIF1A, which should stabilize binding of TC and eIF1 to the scanning PIC prior to AUG recognition. Indeed, we showed that mutations at the eIF2beta:eIF1 interface increase aberrant recognition of UUG codons *in vivo*—the expected consequence of shifting the system from the open to closed conformations—thus establishing the physiological relevance of the py48S-open and py48S-closed structures.

## eIF4B and DEAD-box RNA helicases Ded1 and eIF4A preferentially stimulate translation of long mRNAs with structured 5' UTRs and low closed-loop potential but with weak dependence on eIF4G.

The RNA helicases eIF4A and Ded1 are believed to resolve mRNA secondary structures that impede ribosome attachment to the mRNA and scanning to the start codon, but whether they perform distinct functions *in vivo* was poorly understood. We compared the effects of mutations in Ded1 or eIF4A on translational efficiencies (TEs) by ribosome profiling. Despite similar reductions in bulk translation, inactivation of Ded1 substantially reduced the relative TEs of over 600 mRNAs, whereas inactivation of eIF4A similarly affected fewer than 40 mRNAs. Ded1-dependent mRNAs show greater than average 5' UTR length and propensity for secondary structure, implicating Ded1 in scanning through structured 5' UTRs. Thus, it appears that Ded1 is critically required for scanning through secondary structures in 5' UTRs, while

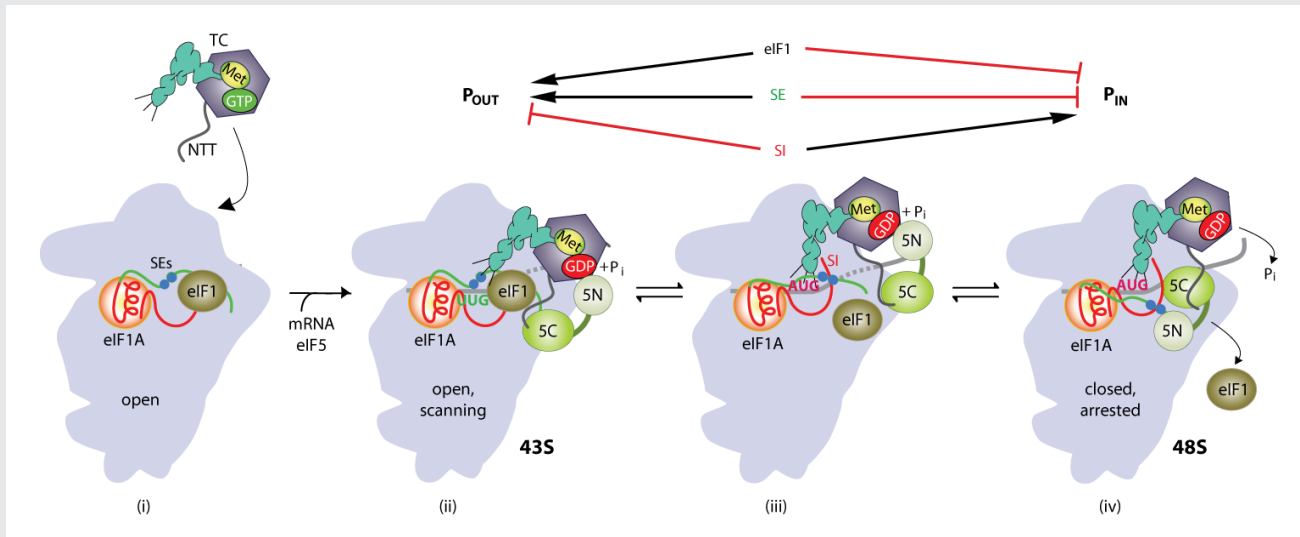

### Model of structural rearrangements in the eukaryotic translation preinitiation complex (PIC) involved in start codon recognition

- (i) Binding of eIF1 and eIF1A to the 40S evokes an open conformation conducive to rapid TC binding, forming the 43S PIC.
- (ii) The 43S scans the mRNA 5' UTR, with the anticodon stem loop (ASL) of Met-tRNA<sub>i</sub> not fully engaged with the P site (P<sub>OUT</sub>) but capable of sampling triplets for complementarity to the anticodon as they enter the P site. The GAP domain in the eIF5-NTT (5N) stimulates GTP hydrolysis to produce GDP-P<sub>i</sub>, but release of P<sub>i</sub> is impeded. The unstructured NTT of eIF2b interacts with eIF1 to stabilize this open conformation of the PIC.
- (iii) Base-pairing between the ASL and AUG codon promotes movement of the tRNA from the P<sub>OUT</sub> to P<sub>IN</sub> state, displacing eIF1 from its location near the P site to a new 40S binding site that overlaps with the eIF5-CTD binding site. This movement of eIF1 eliminates its interaction with the eIF2b NTT, and the latter interacts tightly with the eIF5-CTD instead.
- (iv) eIF1 dissociates from the 40S subunit to stabilize the closed, scanning-incompatible conformation of the 40S subunit. Ejection of eIF1 allows the eIF5-NTT to dissociate from the G domain of eIF2g and bind to the 40S subunit at a location overlapping the eIF1 binding site, facilitating a functional interaction with the eIF1A-CTT that triggers release of P<sub>i</sub> from eIF2-GDP, and blocking reassociation of eIF1 with the 40S subunit. (Published in Hinnebusch AG. The scanning mechanism of eukaryotic translation initiation. *Annu Rev Biochem* 2014;83:779.)

eIF4A promotes a step of initiation common to nearly all mRNAs, such as ribosome attachment. Ribosome profiling of a mutant lacking eIF4B showed that eliminating eIF4B preferentially impacts mRNAs with long structured 5' UTRs and reduces the relative TEs of many more genes than does inactivation of eIF4A. The findings support an eIF4A-independent role for eIF4B in addition to its known function as eIF4A cofactor. Mutations in eIF4B, eIF4A, and Ded1 also preferentially impair translation of longer mRNAs in a manner mitigated by the ability to form closed-loop mRNPs via eIF4F-Pab1 association, suggesting cooperation between closed-loop assembly and eIF4B/helicase functions in stimulating initiation.

### Rli1/ABCE1 recycles terminating ribosomes and controls translation reinitiation in 3' UTRs *in vivo*.

Ribosome recycling is the final phase of protein synthesis, following release of the completed polypeptide chain from the ribosome at the stop codon. ABCE1 (ATP binding cassette subfamily E member 1; yeast Rli1)



has been shown to catalyze removal of the 60S subunit from post-termination complexes *in vitro* but not to be crucial for recycling *in vivo*. In collaboration with Rachel Green's lab, we used ribosome profiling to show that depletion of Rli1 in yeast evokes accumulation of 80S ribosomes at stop codons and in the adjoining 3' UTRs of most genes. Predicted 3' UTR translation was detected by Western analysis and mass spectrometry of epitope-tagged strains, and their small sizes indicate a reinitiation mechanism whereby, following polypeptide release at the stop codon, unrecycled 80S ribosomes resume translation at a nearby sense codon. Thus, Rli1 is crucial for ribosome recycling *in vivo* and to prevent inappropriate 3' UTR translation.

## Genome-wide cooperation by histone acetyl transferase Gcn5, remodeler SWI/SNF, and chaperone Ydj1 in promoter nucleosome eviction and transcriptional activation

We investigated the mechanism of promoter nucleosome eviction by analyzing the effects of mutations in one or more chromatin remodeling complexes, histone acetyltransferase (HAT) complexes, or histone chaperone on eviction of histone H3 at the hundreds of genes in the Gcn4 transcriptome during their induction by Gcn4. By conventional chromatin immunoprecipitation analysis (ChIP) of four canonical Gcn4 target genes, *ARG1*, *HIS4*, *ARG4*, and *CPA2*, we excluded a requirement for several co-factors implicated previously at other genes (e.g., Asf1, Nap1, RSC) and implicated the remodeler SWI/SNF (Snf2), HAT Gcn5, and Hsp70 co-chaperone Ydj1 in nucleosome eviction at these Gcn4 target genes. Expanding our analysis genome-wide by H3 ChIP-Seq, we found that Snf2, Gcn5, and Ydj1 collaborate in evicting H3 from the -1 and +1 promoter nucleosomes and intervening nucleosome-depleted region (NDR) at a large fraction of the Gcn4 transcriptome. We found that the three cofactors function similarly at virtually all yeast promoters. Surprisingly, however, defective H3 eviction in co-factor mutants was coupled with reduced transcription (Pol II densities measured by Rpb3 ChIP-Seq) for only a subset of genes, which included the induced Gcn4 transcriptome and the most highly expressed subset of constitutively expressed yeast genes. In fact, the most weakly expressed genes displayed higher transcription than other genes in response to global attenuation of nucleosome eviction. We thus established that steady-state eviction of promoter nucleosomes is required for maximal transcription of highly expressed genes and that Gcn5, Snf2, and Ydj1 function broadly in this step of gene activation, but we discovered unexpectedly that some other aspect of transcriptional activation is more generally rate-limiting for transcription of most genes in amino acid-deprived yeast.

## Publications

1. Zhang F, Saini AK, Shin BS, Nanda J, Hinnebusch AG. Conformational changes in the P site and mRNA entry channel evoked by AUG recognition in yeast translation preinitiation complexes. *Nucleic Acids Res* 2015 43:2293-2312.
2. Sen ND, Zhou F, Ingolia NT, Hinnebusch AG. Genome-wide analysis of translational efficiency reveals distinct but overlapping functions of yeast DEAD-box RNA helicases Ded1 and eIF4A. *Genome Res* 2015 25:1196-1220.
3. Young DJ, Guydosh NR, Zhang F, Hinnebusch AG, Green R. Rli1/ABCE1 recycles terminating ribosomes and controls reinitiation in 3'UTRs *in vivo*. *Cell* 2015 162:872-884.
4. Llacer JL, Hussain T, Marler L, Aitken CE, Thakur A, Lorsch JR, Hinnebusch AG. Conformational differences between open and closed states of the eukaryotic translation initiation complex. *Mol Cell* 2015 59:399-412.
5. Qiu H, Chereji RV, Hu C, Cole HA, Rawal Y, Clark DJ, Hinnebusch AG. Genome-wide cooperation by HAT

Gcn5, remodeler SWI/SNF, and chaperone Ydj1 in promoter nucleosome eviction and transcriptional activation. *Genome Res* 2016 26:211-225.

6. Sen ND, Zhou F, Harris MS, Ingolia NT, Hinnebusch AG. eIF4B stimulates translation of long mRNAs with structured 5' UTRs and low closed-loop potential but weak dependence on eIF4G. *Proc Natl Acad Sci USA* 2016 113:10464-10472.

## Collaborators

- Katsura Asano, PhD, *Kansas State University, Manhattan, KS*
- David Clark, PhD, *Section on Chromatin and Gene Expression, NICHD, Bethesda, MD*
- Rachel Green, PhD, *The Johns Hopkins University School of Medicine, Baltimore, MD*
- Nicholas Ingolia, PhD, *University of California Berkeley, Berkeley, CA*
- Jon Lorsch, PhD, *Laboratory on the Mechanism and Regulation of Protein Synthesis, NICHD, Bethesda, MD*
- Venkatraman Ramakrishnan, PhD, *MRC Laboratory of Molecular Biology, Cambridge, UK*
- Gerhard Wagner, PhD, *Harvard Medical School, Boston, MA*

## Contact

For more information, email [ahinnebusch@nih.gov](mailto:ahinnebusch@nih.gov) or visit <http://sncge.nichd.nih.gov>.

## Molecular Nature and Functional Role of Dendritic Voltage-Gated Ion Channels

The central nervous system underlies all our experiences, actions, emotions, knowledge, and memories. With billions of neurons each firing hundreds of times per second, the complexity of the brain is stunning. To pare down the task of understanding something so complex, our research approach calls for studying the workings of a single central neuron—the pyramidal neuron from the CA1 region of the hippocampus. The hippocampus is essential for long-term memory in humans and is among the first brain regions affected by epilepsy and Alzheimer’s disease. To understand how the hippocampus stores and processes information, we focus on one of its principal cell types, the CA1 pyramidal neuron. Each pyramidal neuron in the CA1 region of the hippocampus receives tens of thousands of inputs onto its dendrites, and it is commonly thought that information is stored by altering the strength of individual synapses (synaptic plasticity). Recent evidence suggests that the regulation of synaptic surface expression of glutamate receptors can, in part, determine synaptic strength. However, the dendrites contain an abundance of ion channels that are involved in receiving, transforming, and relaying information in the dendrites, adding an additional layer of complexity to neuronal information processing.

We found that the A-type potassium channel subunit Kv4.2 is highly expressed in the dendritic regions of CA1 neurons in the hippocampus and, as one of the primary regulators of dendritic excitability, plays a pivotal role in information processing. Kv4.2 is targeted for modulation during the types of plasticity thought to underlie learning and memory. Moreover, we found that the functional expression level of Kv4.2 regulates the subtype expression of NMDA-type glutamate receptors, the predominant molecular devices controlling synaptic plasticity and memory. We are currently following up on these findings with more detailed investigations into the mechanisms of activity-dependent Kv4.2 regulation. In addition, we have begun investigating the role of dendritic voltage-gated channels in neuronal development and developmental disorders.

### Role of voltage-gated ion channels in synaptic development and disease

#### CALCIUM REGULATION OF TRANSIENT K<sup>+</sup> CURRENTS

The sub-threshold activating, A-type potassium current (IA) has long been recognized as a critical component for regulating dendritic



**Dax Hoffman, PhD**, *Head, Section on Molecular Neurophysiology and Biophysics*

Jiahua Hu, PhD, *Staff Scientist*

Lin Lin, PhD, *Microbiologist*

Ying Liu, MD, *Biologist*

Jakob Gutzmann, PhD, *Visiting Fellow*

Erin Gray, PhD, *Postdoctoral Fellow*

Jon Murphy, PhD, *Postdoctoral Research Associate Program (PRAT) Fellow*

Travis Tabor, BS, *Postbaccalaureate Fellow*

excitability and shaping back-propagating action potentials. In CA1 pyramidal cells of the hippocampus IA is carried predominantly by Kv4.2 potassium channels, which are associated with a variety of accessory proteins that modulate their trafficking and kinetics. Among these interacting proteins are K-channel-interacting proteins (KChIPs), small cytoplasmic proteins with four calcium-binding EF-Hand motifs and dipeptidyl-peptidase-like proteins (DPPs). IA shows a distinct functional gradient along the apical dendrites of CA1 pyramidal neurons. The reciprocal relationship between Kv4.2 and the GluN2B subunit of the *N*-methyl-D-aspartate (NMDA) receptor, and its interaction with the voltage-gated calcium channel Cav2.3 opens up the possibility of calcium-dependent effects on Kv4.2 function in the synapse. Using a mutated KChIP construct that is unable to bind to calcium but still interacts with Kv4.2, Jakob Gutzmann found that changes in intracellular calcium concentration alters many Kv4.2-mediated current properties in the presence of KChIPs in a heterologous expression system. All these effects were abolished when we used a KChIP2a construct whose ability to bind to calcium was mutated. Performing these experiments in the more physiological environment of acute hippocampal slices led to similar results. We are now recording IA from somatic and dendritic outside-out patches in mice, in order to better understand the interplay between calcium and potassium that shapes CA1 pyramidal cells' electrical behavior.

### ISOMERASE REGULATION OF POTASSIUM CHANNEL TRAFFICKING AND FUNCTION

To identify Kv4.2 binding proteins, Jiahua Hu employed a tandem affinity purification approach (TAP) to isolate the Kv4.2 protein complex from hippocampal neurons. Mass-spectrometry analysis identified known proteins such as KChIP family members and DPP6/10. The TAP-MS assay also identified an isomerase as a binding partner of Kv4.2. The binding was confirmed by brain co-immunoprecipitation, co-expression in HEK293T cells, and peptide pull down *in vitro*. The isomerase binds to a specific Kv4.2 site, and the association is regulated by neuronal activity and seizure. The isomerizing activity may regulate Kv4.2 binding to its auxiliary subunits, suggesting that the isomerase plays a role in Kv4.2 function. To further study the physiological function of isomerase and Kv4.2 channel, we are generating a knockin mouse in which the isomerase binding site is specifically abolished.

### DPP6 DELETION LEADS TO MEMORY IMPAIRMENTS IN MICE.

We previously showed that the Kv4 A-type K<sup>+</sup> auxiliary subunit DPP6 plays important roles hippocampal synaptic development and function but that the behavioral effects of DPP6-KO (knockout) mice are unknown. Lin Lin focused on hippocampus-dependent tasks involved in recognition and learning memory. We found DPP6-KO mice to be impaired in recognition memory with a Novel Object Recognition task. In the Water Maze, DPP6-KO mice showed slow learning and impaired memory performance. In a T-Maze task, the success rate of wild-type (WT) mice rose over the course of the training, while DPP6-KO mice started and finished with the same success rate without any significant learning throughout the training. Taken together, we find that DPP6 deletion leads to behavioral impairments in recognition and spatial learning and memory. We are investigating whether the behavioral deficits can be changed or rescued by DPP6 microinjected by *in utero* electroporation (IUE) in DPP6-KO mice.

### LOSS OF REGULATED CAV2.3 EXPRESSION IN A MOUSE MODEL OF FRAGILE X SYNDROME

Fragile X syndrome (FXS) is a severe form of intellectual disability in humans, which arises from the loss of the fragile X mental retardation protein (FMRP), an mRNA-binding protein that regulates translation downstream of group I metabotropic glutamate receptors (Gpl mGluRs). Loss of FMRP leads to enhanced calcium spiking and neuronal excitability. Erin Gray therefore sought to explore the possibility that FMRP

**FIGURE 1.** Elevated levels of Cav2.3 mRNA can be detected in the cell body and proximal dendrites in a mouse model of Fragile X syndrome.

A) Maximum intensity projection photomicrographs of WT mouse neurons showing Cav2.3 mRNA fluorescence *in situ* hybridization signal (left, red), overlaid nucleus (DAPI), and dendrite (Map2) cyto-architectural markers (middle), and a three-color composite image (right).

B) Straightened dendrites demonstrating Cav2.3 mRNA transcript *in situ* staining (red) in a dendrite identified by Map2 immuno-cytochemistry (green).

C) Maximum intensity projection photomicrographs of FMRP-KO mouse neurons arranged as in "A".

D) Straightened dendrites of FMRP-KO mouse neurons arranged as in "B".

E) Comparison of normalized mean fluorescence intensity of Cav<sub>v</sub>2.3 mRNA *in situ* measured at the neuronal cell body of WT and FMRP-KO mouse neurons.

F) Comparison of the mean fluorescence intensity of Cav<sub>v</sub>2.3 mRNA *in situ* in 20-micron bins extending from the neuronal cell body.

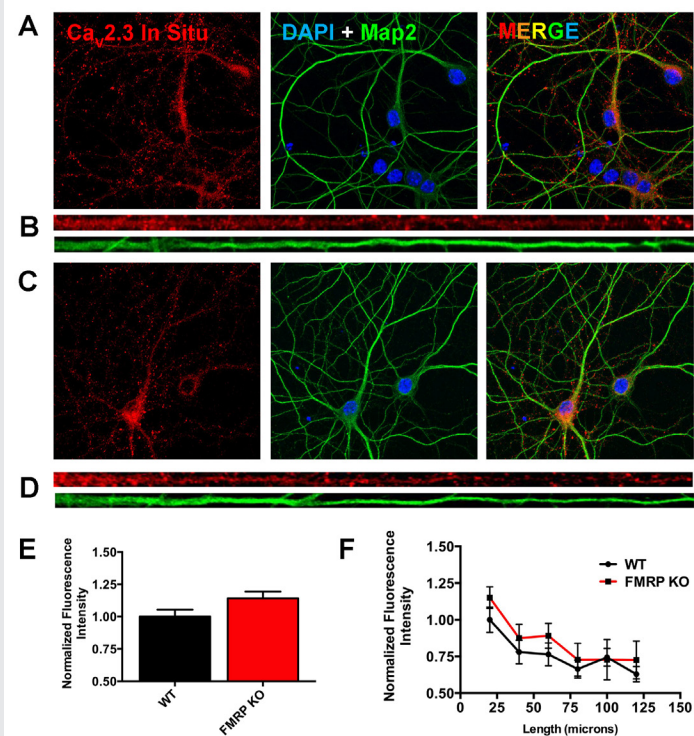

regulates expression of the dendritic voltage-gated calcium channel Cav2.3. We had found previously that the cortices of FMRP-KO mice exhibit enhanced levels of Cav2.3 under basal conditions, and we were curious to know how loss of FMRP might affect Cav2.3 expression in the hippocampus. We performed Western blotting to measure Cav2.3 protein levels from either acutely isolated or cultured hippocampal neurons and, similar to our previous findings in cortex, we found that the FMRP-KO mice exhibit enhanced expression of Cav2.3 in the hippocampus. The increase in Cav2.3 expression should impact neuronal physiology; therefore, we isolated Cav2.3 currents using whole-cell electrophysiology in cultured hippocampal neurons from WT and FMRP-KO mice. As predicted from our Western blot data, FMRP-KO neurons exhibited greatly enhanced Cav2.3 current amplitudes. Thus, it appears that FMRP normally represses Cav2.3 translation under basal conditions and that loss of FMRP leads to an increase in Cav2.3 protein in the membrane. We are also investigating the possibility that the FMRP repression of Cav2.3 expression can be regulated by upstream activity of Gpl mGluRs. In support of this idea, our previous data showed that stimulation of Gpl mGluRs does indeed increase Cav2.3 translation and expression in WT neurons but not in neurons lacking FMRP. Next, to determine whether FMRP regulates translation of existing Cav2.3 mRNA or whether transcription is required, we applied the transcriptional blocker Actinomycin D (ActD) to cultured neurons while stimulating Gpl mGluRs. Treating neurons with ActD did not significantly inhibit the stimulation of Cav2.3 expression, suggesting that Gpl mGluRs raise Cav2.3 protein by inducing translation of existing mRNA bound to FMRP. Taken together, our data suggest that FMRP represses translation of Cav2.3 under basal conditions and that activation of Gpl mGluRs disinhibits FMRP to allow for active translation of Cav2.3. The loss of regulated Cav2.3 expression seen in the FMRP KO may underlie the atypical calcium signaling and neuronal excitability seen in FXS and may thus be a potential therapeutic target in this disease.

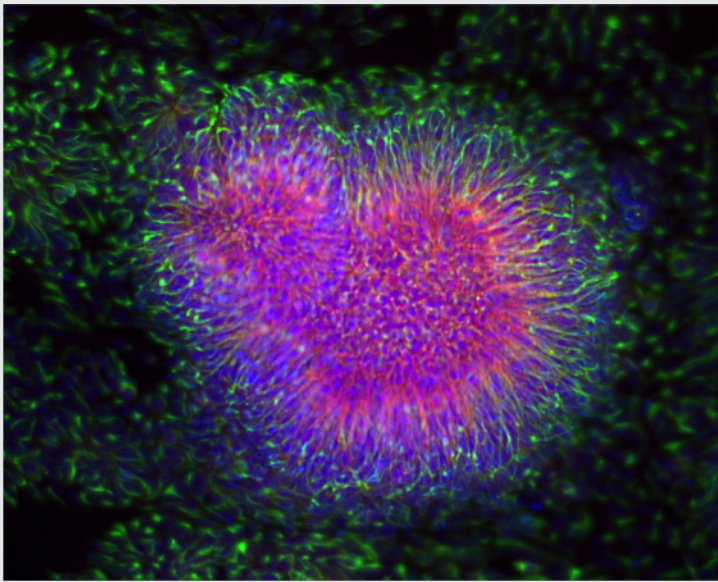

**FIGURE 2. Cellular and molecular phenotypes associated with idiopathic autism in iPSC-derived neurons**

Immuno-fluorescence images of human induced pluripotent stem cell (iPSCs)-derived neuronal progenitor cells showing “neural rosette structure,” where neuro-epithelial cells arrange radially around a lumen. Cells were stained with PAX6 (red), NESTIN (green) and DAPI (blue).

#### FMRP INTERACTS WITH CAV2.3 MRNA.

Ying Liu showed that Cav2.3 mRNA levels were altered in FMRP-KO neurons and that Cav2.3 protein levels were significantly enhanced in the FMRP KO. To determine whether Cav2.3 mRNA is one of the targets of FMRP, we performed RNA immunoprecipitation. Our data showed that FMRP interacts with Cav2.3 mRNA in transfected HEK293 cells and in mouse cortex and hippocampus. Our results suggest that FMRP binds to Cav2.3 mRNA directly or indirectly to repress Cav2.3 translation and regulate neuronal excitability.

In related work, using the FMRP-KO mouse, Jon Murphy is examining whether dendritic FMRP regulates mRNA trafficking and protein expression of Cav2.3 and Kv4.2 in the dendrites of hippocampal neurons (Figure 1). Recent work centered primarily on analysis of mRNA localization and regulation of total protein translation in neuronal dendrites of WT and FMRP-KO mouse neurons. Using fluorescence *in situ* hybridization to detect mRNAs for Cav2.3 and CaMKII (Ca<sup>2+</sup>/calmodulin-dependent protein kinase II) in neurons, we have found that the abundance of CaMKII mRNA, which encodes a known dendritically synthesized protein, is elevated throughout the dendritic arbor of FMRP-KO mice. FMRP is known to inhibit CaMKII translation through direct binding to CaMKII mRNA, suggesting that either CaMKII mRNA is more highly transcribed in FMRP-KO mice, or that it is no longer sequestered in mRNA-protein complexes where *in situ* hybridization is inhibited, or both. Conversely, Cav2.3 mRNA signals are low throughout dendrites in both WT and FMRP-KO neurons. Studies of Kv4.2 mRNA localization in WT and FMRP-KO neurons are ongoing.

#### CELLULAR AND MOLECULAR PHENOTYPES ASSOCIATED WITH IDIOPATHIC AUTISM IN IPSC-DERIVED NEURONS

Idiopathic autism is an early onset neurodevelopmental disorder that may result from genetic variation in multiple genes. We generated induced pluripotent stem cells (iPSCs) from three patients with intrinsic autism as well as from controls (Figure 2); the autistic iPSCs were subsequently differentiated into electrophysiologically active neurons comparable to control cells. Autistic iPSC-derived neurons displayed

significant decreases in both Na<sup>+</sup> and fast K<sup>+</sup> voltage-gated currents but not in Ca<sup>2+</sup> and slow K<sup>+</sup> voltage-gated currents. The defects accounted for the observation that autistic iPSC-derived neurons reach faster action potential saturation and are slightly more excitable than controls. We found that the amplitude and frequency of spontaneous excitatory postsynaptic currents from autistic neurons were significantly lower than in controls, indicating defects in excitatory synaptic transmission (Reference 4).

## Additional Funding

- Postdoctoral Research Associate Program (PRAT) Fellowship (Jon Murphy)

## Publications

1. Hall AM, Throesch BT, Buckingham SC, Markwardt SJ, Peng Y, Wang Q, Hoffman DA, Roberson ED. Tau-dependent Kv4.2 depletion and dendritic hyperexcitability in a mouse model of Alzheimer's disease. *J Neurosci* 2015 35(15):6221-6230.
2. Murase S, Lantz CL, Kim E, Gupta N, Higgins R, Stopfer M, Hoffman DA, Quinlan EM. Matrix metalloproteinase-9 regulates neuronal circuit development and excitability. *Mol Neurobiol* 2015 53(5):3477-3493.
3. Li W, Lee MH, Henderson L, Tyagi R, Bachani M, Steiner J, Campanac E, Hoffman DA, von Geldern G, Johnson K, Maric D, Morris HD, Lentz M, Pak K, Mammen A, Ostrow L, Rothstein J, Nath A. Human endogenous retrovirus-K contributes to motor neuron disease. *Sci Transl Med* 2015 7(307):307ra153.
4. Liu X, Campanac E, Cheung HH, Ziats MN, Canterel-Thouennon L, Raygada M, Baxendale V, Pang AL, Yang L, Swedo S, Thurm A, Lee TL, Fung KP, Chan WY, Hoffman DA, Rennert OM. Idiopathic autism: cellular and molecular phenotypes in pluripotent stem cell-derived neurons. *Mol Neurobiol* 2016; Epub ahead of print.
5. Sertedaki A, Markou A, Vlachakis D, Kossida S, Campanac E, Hoffman DA, Sierra ML, Xekouki P, Stratakis CA, Kaltsas G, Piaditis GP, Chrousos GP, Charmandari E. Functional characterization of two novel germline mutations of the KCNJ5 gene in hypertensive patients without primary aldosteronism but with ACTH-dependent aldosterone hypersecretion. *Clin Endocrinol (Oxf)* 2016 85(6):845-851.

## Collaborators

- Sachiko Murase, PhD, *Laboratory of Molecular Biology, NINDS, Bethesda, MD*
- Avindra Nath, MD, *Translational Neuroscience Center, NINDS, Bethesda, MD*
- Owen M. Rennert, MD, *Laboratory of Clinical Genomics, NICHD, Bethesda, MD*
- Eric Roberson, MD, PhD, *University of Alabama, Birmingham, AL*
- Constantine A. Stratakis, MD, D(med)Sci, *Section on Endocrinology and Genetics, NICHD, Bethesda, MD*
- Paul Worley, MD, *The Johns Hopkins University, Baltimore, MD*

## Contact

For more information, email [dh347r@nih.gov](mailto:dh347r@nih.gov) or visit <https://neuroscience.nih.gov/Faculty/Profile/dax-hoffman.aspx>.

## Mechanisms of and Rational Remedies for Inherited Neurometabolic Disorders

The Section of Translational Neuroscience strives to dissect and understand mechanisms of human neurometabolic disease and to use the knowledge gained to develop rational remedies, including gene therapy. Core values that guide the Section's efforts include integrity, humility, hard work with purpose, moving forward rapidly, concern for patients and their families, and mutual support among laboratory members. In addition to molecular genetics, we employ model organisms (mouse, zebrafish, yeast) and cellular, biochemical, and biophysical approaches, and we conduct clinical trials. Preclinical work in the laboratory currently focuses on viral gene therapy in mouse models of Menkes disease and lysosomal storage disease. On the basic neuroscience side, we pursue the molecular mechanisms responsible for certain forms of motor neuron degeneration, utilizing murine and zebrafish models, as well as mouse primary motor neuron cultures.

### ATP7A-related copper transport disorders

The P-type ATPase ATP7A is a transmembrane protein with a distinctive intracellular trafficking itinerary essential for proper human copper transport. Mutations in *ATP7A* lead to Menkes disease, occipital horn syndrome (OHS), or an isolated adult-onset distal motor neuropathy (DMN), phenotypes that encompass variable neurologic disability and lifespan. The past several years has witnessed identification of additional human disorders involving gene products that normally coordinate with ATP7A and which, when mutated, can impair copper metabolism.

Through mutagenesis and immunoprecipitation studies, we recently identified a cryptic ubiquitin regulatory X (UBX) domain in the third luminal loop of ATP7A (between transmembrane segments 5 and 6) that becomes exposed through the conformational effects of a DMN-causing mutation, T994I, and binds to the multi-functional ATPase p97/VCP. Confocal imaging, total internal reflection fluorescence (TIRF) microscopy, and live-cell permeabilization experiments all suggest that the abnormal interaction occurs at the plasma membrane of cells. The UBX domains contain an 80-amino acid ubiquitin-like sequence, including a conserved FP (Phe-Pro) dipeptide implicated in p97/VCP binding. The motif in ATP7A



**Stephen G. Kaler, MD, Head,**  
*Section on Translational  
Neuroscience*

Ling Yi, PhD, *Staff Scientist*

Eun-Young Choi, PhD,  
*Postdoctoral Fellow*

Marie-Reine Haddad, PhD,  
*Postdoctoral Fellow*

Diego Martinelli, MD, PhD, *Visiting  
Fellow*

Kristen Stevens, RN, CPNP,  
*Research Nurse Practitioner*

Julienne Price, BS,  
*Postbaccalaureate Fellow*

Sokena Zaidi, BS,  
*Postbaccalaureate Fellow*





#### Members of the Section on Translational Neuroscience

Left to right: Eun-Young Choi, PhD; Marie Reine Haddad, PhD; Stephen Kaler, MD; Diego Martinelli, MD; Ling Yi, PhD; Kristen Stevens, RN, CPNP

(F971/P972) is 22 residues proximal to T994, and mutation of F971/P972 to alanine residues dramatically diminishes the ATP7A–T994I interaction with p97/VCP. Mutations in *p97/VCP* itself cause several other inherited motor neuron diseases, confirming a link between this abnormal interaction and motor neuron degeneration. Emerging preliminary data from our characterization of this and another DMN-inducing ATP7A missense mutation in zebrafish and mouse models also appear promising.

Mutations in the acetyl-coA transporter gene *SLC33A1* cause Huppke-Brendel syndrome, a complex autosomal recessive phenotype that features congenital cataracts, hearing loss, profound neurodevelopmental delay, and death during infancy or early childhood. The presence of low serum copper and ceruloplasmin and cerebellar atrophy similar to Menkes disease in affected patients implies possible effects on ATP7A. *SLC33A1* normally mediates N-terminal acetylation, a reversible post-translational modification of numerous proteins, including at least six other ATPases. We employed tandem mass spectroscopy to document acetylation of ATP7A, used CRISPR/Cas9 to knock out *SLC33A1* in HEK293T cells, and studied ATP7A trafficking in response to copper stimulation after over-expression of a Venus-tagged ATP7A construct. In contrast to normal HEK293T cells, ATP7A in *SLC33A1* knockout cells fails to traffic from the *trans*-Golgi compartment to the plasma membrane upon high copper loading. Cultured fibroblasts from three affected patients also show defective endogenous ATP7A trafficking after copper loading. These findings help explain the clinical and biochemical phenotypes of this condition and suggest that acetylation of ATP7A is involved in copper-responsive ATP7A trafficking.

For classic Menkes disease, the impact of existing and developing treatments, including viral gene therapy, would be enhanced by newborn screening (NBS), given that brain degeneration in affected infants typically begins by 6 to 8 weeks of age and leads to death by three years. The distinctively abnormal neurochemical

metabolites in Menkes newborns are not amenable to detection in standard high volume NBS platforms owing to the need for an alumina extraction step. Interest in the application of genomic technologies to NBS has heightened in recent years based on proof-of-concept studies involving DNA sequence analysis from dried newborn blood spots. In a blinded pilot study of 15 affected Menkes patients, 100% of *ATP7A* mutations found by conventional mutation detection methods were detected accurately and efficiently from dried blood spots on NBS cards, auguring well for future population-based application. These advances in early detection and *ATP7A* gene replacement have the potential to transform the natural history of Menkes disease, by circumventing the largest current barriers to good health in affected patients.

## Viral gene therapy for lysosomal storage diseases

Choroid plexus (CP)-targeted gene therapy represents a promising approach to the treatment of lysosomal storage diseases (LSDs) that impact the CNS. Intrathecal delivery (by injecting enzyme into the cerebrospinal fluid during a spinal tap) of recombinant lysosomal enzymes has been successful in ameliorating LSDs in some animal studies and in human clinical trials. However, a major drawback to this approach is the need for repeated (e.g., monthly) intrathecal injections owing to the short half-lives of recombinant enzymes. An alternative strategy is to remodel CP epithelial cells with an AAV vector containing the cDNA for the enzyme of interest. Given the extremely low turnover rate of CP epithelia, the approach could generate a permanent source of enzyme production for secretion into the CSF and penetration into cerebral and cerebellar structures. For the project supported by our 2014 NIH U01 Award, entitled "Choroid plexus-directed gene therapy for alpha-mannosidosis" and conducted in collaboration with John Wolfe, we are using mouse and cat models to evaluate choroid plexus transduction by several rAAV vectors as well as post-treatment alpha-mannosidase concentration and distribution in brain. Studies in the mouse model will require less virus and the mice will be easier to breed. The cat model (housed at the University of Pennsylvania) features a gyrencephalic brain more similar to the human brain. Thus, the study of these two models will be complementary. In a related Bench-to-Bedside study, we are collaborating with Patricia Dickson to compare the efficiency of CP-mediated lysosomal enzyme production in a mouse model of mucopolysaccharidosis type 3B (Sanfilippo B syndrome).

## Maternal and child health issues in survivors of the West Africa Ebola epidemic

In collaboration with NIAID, the Section participated in the Trans-NIH response to the 2014–2016 Ebola epidemic in Liberia, including a vaccine clinical trial (PREVAIL-1) and natural history study of survivors (PREVAIL-3). In contrast to adeno-associated virus gene therapy in which the brain's immunoprivileged status is advantageous, the Ebola filovirus poses neurocognitive risks in survivors of the acute infection owing to immune sanctuary sites within the central nervous system (CNS).

While pregnancy during acute Ebola virus disease (EVD) has been almost invariably associated with fetal loss, little is understood about the antenatal courses and pregnancy outcomes in female EVD survivors who conceived after recovery. We collated demographic and treatment history data on women who recovered from Ebola and sought healthcare during the period of October 2014 through April 2016 at designated referral facilities (JFK Hospital, ELWA Hospital, Redemption Hospital or Duport Road Health Center in Montserrado County; Dolo Town Health Center, Hindi Clinic, Worhn Clinic or C.H. Rennie in Margibi County). Approval for data collection was via the Ministry of Health (MOH) Incident Management System for overseeing the Liberian response to Ebola. History of confirmed EVD was verified using the official MOH

database. Maternal age, number of months between discharge from an Ebola Treatment Unit (ETU) and conception, frequency of antenatal care (ANC), and pregnancy outcomes were analyzed. A total of 70 EVD survivors from Montserrado (54) and Margibi (16) Counties were evaluated. Fifteen women miscarried; four neonates were stillborn (defined as fetal death at or after 28 weeks gestation); and two EVD survivors elected to terminate their pregnancies. Mean age and number of ANC visits per month of pregnancy were not significantly different between the group of 49 whose pregnancies resulted in normal births and 19 women who experienced stillbirth or miscarriage. In seven cases, the mothers' partners also were also EVD survivors; six of the seven had apparently normal infants and one had a miscarriage.

Notably, of six conceptions that occurred within two months of ETU discharge, three (50%) resulted in stillbirths. One additional stillbirth occurred in a pregnancy conceived six months after recovery. In contrast, all fifteen miscarriages occurred in women who became pregnant four months or longer after ETU discharge. The mean interval in months between recovery from acute EVD and conception was significantly shorter in subjects who suffered stillbirths versus miscarriage ( $2.5 \pm 2.4$  versus  $9.9 \pm 3.0$  months). The overall miscarriage rate in clinically identified pregnancies for this cohort of Ebola survivors (15/68; 22.1%) was slightly higher than the ranges expected for healthy women in developed countries (10 to 15%) and women in West Africa (11 to 13%). Taken together, the rate of adverse pregnancy outcomes in this cohort (19/68; 27.9%) suggests that EVD engenders reproductive health risks after clinical disease has been resolved, especially when pregnancy occurs within two months of recovery. Prospective evaluation of additional pregnancy outcomes in EVD survivors compared with age-matched controls from West Africa will be helpful to further quantify the relative risks of adverse pregnancy outcomes.

## Clinical research protocols

1. Principal Investigator, 90-CH-0149: Early copper histidine treatment in Menkes disease: relationship of molecular defects to neurodevelopmental outcomes
2. Principal Investigator, 09-CH-0059: Molecular bases of response to copper treatment in Menkes disease, related phenotypes, and unexplained copper deficiency
3. Principal Investigator, 14-CH-0106: Clinical biomarkers in alpha-mannosidosis
4. Associate Investigator, Partnership for Research on Ebola Virus in Liberia PREVAIL III (15-I-N122); Monrovia, Liberia
5. Sub-Investigator, Partnership for Research on Ebola Virus in Liberia PREVAIL I (15-I-N071); Monrovia, Liberia
6. Associate Investigator; Phase II Study of AAV9-GAA gene transfer in Pompe disease (NHLBI U01 Award, Co-PIs: B. Byrne/A. Arai)
7. Principal Investigator, Clinical biomarkers in Sanfilippo type B
8. Principal Investigator, Pilot study of NORTHERA for dysautonomia in Menkes disease and occipital horn syndrome

## Patents filed

Patent 4239-81164-01: Identification of subjects likely to benefit from copper treatment. International Filing Date: 06 October, 2008

PCT/US2016/058124: Codon-optimized reduced-size ATP7A cDNA and uses for treatment of copper transport disorders. Filing date: October 21, 2016.

## Additional Funding

- 2015 NIH Bench-to-Bedside Award (Kaler/Petris/Feldman). Mechanisms and treatment of motor neuron disease associated with copper metabolism defects
- U01-CH-079066-01. Choroid plexus-directed gene therapy for alpha-mannosidosis
- U01-HL121842-01A1. Phase II study of AAV9-GAA gene transfer in Pompe disease
- 2016 NIH Bench-to-Bedside Award (Kaler/Dickson). Phenotypic effects of gene therapy to the choroid plexus epithelium for Sanfilippo B

## Publications

1. Fallah MP, Skrip LA, Dahn BT, Nyenswah TG, Flumo H, Glayweon M, Lorseh TL, Kaler SG, Higgs ES, Galvani AP. Pregnancy outcomes in Liberian women who conceived after recovery from Ebola virus disease. *Lancet Glob Health* 2016 4:678-679.
2. Kaler SG. Microbial peptide de-coppers mitochondria: implications for Wilson disease. *J Clin Invest* 2016 126:2412-2414.
3. Bhattacharjee A, Yang H, Duffy M, Robinson E, Conrad-Antoville A, Lu YW, Capps T, Braiterman L, Wolfgang M, Murphy MP, Yi L, Kaler SG, Lutsenko S, Ralle M. The activity of Menkes disease protein ATP7A is essential for redox balance in mitochondria. *J Biol Chem* 2016 291:16644-16658.
4. Ling Y, Kaler SG. Direct interactions of adaptor protein complexes 1 and 2 with the copper transporter ATP7A mediate its anterograde and retrograde trafficking. *Hum Mol Genet* 2015 24:2411-2425.
5. Bandmann O, Weiss KH, Kaler SG. Wilson's disease and other neurological copper disorders. *Lancet Neurol* 2015 14:103-113.

## Collaborators

- Eva Baker, MD, PhD, *Radiology and Imaging Sciences, NIH Clinical Center, Bethesda, MD*
- Andy Bhattacharjee, PhD, *Parabase Genomics, Boston, MA*
- Lauren Brinster, VMD, *Division of Veterinary Resources, Office of Research Services, NIH, Bethesda, MD*
- Sara Cathey, MD, *Greenwood Genetics Center, Greenwood, SC*
- Jose Centeno, PhD, *Walter Reed Army Medical Center, Silver Spring, MD*
- John Chiorini, PhD, *Molecular Physiology and Therapeutics Branch, NIDCR, Bethesda, MD*
- Patricia Dickson, MD, *Harbor-UCLA Medical Center, Los Angeles, California*
- Mosoka P. Fallah, PhD, *Ministry of Health, Monrovia, Liberia; NIAID Prevail-III Study*
- David S. Goldstein, MD, PhD, *Clinical Neurosciences Program, NINDS, Bethesda, MD*
- Courtney Holmes, CMT, *Clinical Neurosciences Program, NINDS, Bethesda, MD*
- Peter Huppke, MD, *Georg August Universität, Göttingen, Germany*
- Robert Kotin, PhD, *University of Massachusetts Medical Center, Worcester, MA*
- Avindra Nath, MD, *Section of Infections of the Nervous System, NINDS, Bethesda, MD*
- Richard Parad, MD, MPH, *Brigham and Women's Hospital, Harvard Medical School, Boston, MA*
- Nicholas Patronas, MD, *Diagnostic Radiology Department, Clinical Center, NIH, Bethesda, MD*
- Michael Petris, PhD, *University of Missouri-Columbia, Columbia, MO*
- Martina Ralle, PhD, *Oregon Health Sciences University, Portland, OR*
- Evan Sadler, MD, PhD, *Washington University, St. Louis, MO*
- Alan N. Schechter, MD, *Molecular Medicine Branch, NIDDK, Bethesda, MD*

- Peter Steinbach, PhD, *Center for Molecular Modeling, CIT, NIH, Bethesda, MD*
- Wen-Hann Tan, MD, *Boston Children's Hospital, Boston, MA*
- John Wolfe, VMD, PhD, *University of Pennsylvania, Philadelphia, PA*

## Contact

For more information, email [sgk@box-s.nih.gov](mailto:sgk@box-s.nih.gov) or visit <http://mmp.nichd.nih.gov/kaler.html>.

## Control of Gene Expression during Development

During development and differentiation, genes become competent to be expressed or are stably silenced in an epigenetically heritable manner. The selective activation/repression of genes leads to differentiation of tissue types. Much evidence supports the model that modifications of histones in chromatin contribute substantially to determining whether a gene is expressed. Two groups of genes, the Polycomb group (*PcG*) and Trithorax group (*TrxG*), are important for inheritance of the silenced and active chromatin state, respectively. In *Drosophila*, regulatory elements called Polycomb group response elements (PREs) are required for the recruitment of chromatin-modifying PcG protein complexes. TrxG proteins may act through the same or overlapping *cis*-acting sequences. Our group aims to understand how PcG and TrxG proteins are recruited to DNA. Toward that end, one major project in the lab has been to determine all sequences and DNA-binding proteins required for PRE activity. In the *Drosophila* genome, there are hundreds of PREs that regulate a similar number of genes, and it was not known whether all PREs are alike. Our recent data showed that there is functional and architectural diversity among PREs, suggesting that PREs adapt to the environment of the gene they regulate. PREs are made up of binding sites for a number of DNA-binding proteins. During the past year, our lab showed that the zinc-finger protein Combgap contributes to PcG recruitment at a subset of PREs.

A second major project in the lab is to determine how the PREs of the *engrailed/invented* gene complex act to control these genes in their native location. Surprisingly, we found that not all PREs are required *in vivo*, suggesting a redundancy in PRE function. To understand the interplay between PREs and enhancers (sequences important for activation of gene expression), we completed an analysis of the regulatory DNA of the *engrailed/invented* (*en/inv*) gene complex. We found that regulatory sequences are spread throughout a region of at least 79kb in that gene complex and that the same enhancers activate both *engrailed* and *invented* expression. The finding lays the groundwork for future studies aimed at understanding how distant regulatory sequences coordinately regulate gene activity. We also conducted a genetic screen to find genes that regulate PRE activity and found an interesting cohesin-Polycomb connection, a project that has now been moved into a collaborative endeavor in the



**Judith A. Kassis, PhD, Head,**  
*Section on Gene Expression*

J. Lesley Brown, PhD, *Staff Scientist*

Yuzhong Cheng, PhD, *Senior Research Technician*

Sandip De, PhD, *Postdoctoral Fellow*

Ming-an Sun, PhD, *Postdoctoral Fellow*

Elizabeth Fishman, BS,  
*Postbaccalaureate Fellow*

Shravya Raju, BA,  
*Postbaccalaureate Fellow*

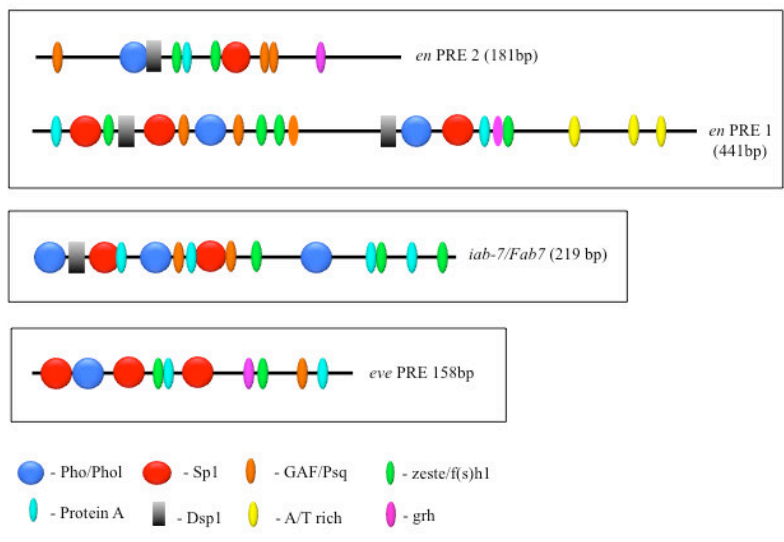

**FIGURE 1.** The order, number, and spatial arrangement of consensus-factor binding sites varies in different PREs.

*en* PRE1 and 2 are from the *engrailed* gene; *iab-7/Fab-7* PRE is from the *Abd-B* gene; *eve* PRE is from the *even-skipped* gene. The symbols represent consensus binding sites for the proteins indicated below. Figure reprinted from Brown JL, Kassis JA. *Genetics* 2013;195:433.

mouse. The aim of these studies is to probe the regulation of gene expression more deeply so as to permit an understanding of how gene expression can malfunction and lead to developmental abnormalities and disease.

## Polycomb group response elements (PREs)

PcG proteins act in protein complexes that repress gene expression by modifying chromatin. The best studied PcG protein complexes are PRC1 and PRC2. PRC2 contains the histone methyltransferase Enhancer of Zeste, which tri-methylates lysine 27 on histone H3 (H3K27me3). The chromatin mark H3K27me3 is the signature of PRC2 function. At most well studied genes, PRC2 acts with PRC1, which binds to H3K27me3 and inhibits chromatin remodeling. In *Drosophila*, PRC1 and PRC2 are recruited to the DNA by PREs (Kassis JA, Brown JL. *Adv Genet* 2013;81:83). We are interested in determining how this occurs, and, to that end, we defined all the DNA sequences and are finding all DNA-binding proteins required for the activity of a single 181-bp PRE of the *Drosophila engrailed* gene (PRE2). Binding sites for seven different proteins are required for the activity of the PRE2 (Figure 1) (Brown JL, Kassis JA. *Genetics* 2013;195:433). There are several binding sites for some of these proteins. Our laboratory identified four PRE-DNA binding proteins, Pho, Phol, Spps, and, most recently, Combgap (Reference 4). The Combgap protein has 10 zinc fingers and recognizes the sequence GTGTGT.

Studies designed to test the function of PREs in transgenes showed that PREs are largely interchangeable in some assays, with subtle activity differences. To determine how similar PREs are, we compared the binding-site arrangements and requirements in two closely linked *engrailed* PREs, PRE1 and PRE2, and compared them with two other PREs in the genome (Figure 1). All these PREs mediate transcriptional repression of the reporter gene *mini-white* in transgenic *Drosophila*, but the arrangement, number, and order of the binding sites vary dramatically among the different PREs. We tested the *engrailed* PREs in another reporter vector, one that gives  $\beta$ -galactosidase expression in embryos, larval salivary glands, and brains (Figure 2). In the

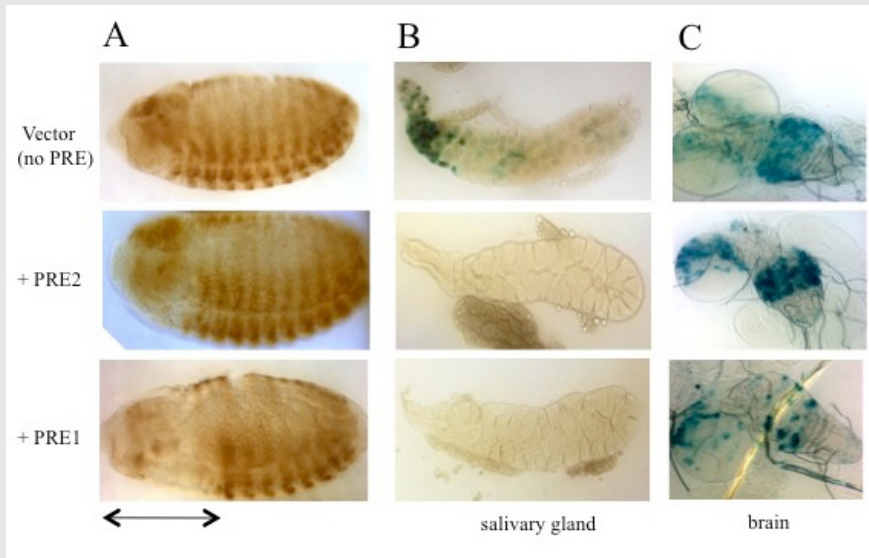

**FIGURE 2. Activity of PRE1 and PRE2 in a transgene reporter construct in embryos and in larval salivary glands and brains**

A. *Drosophila* embryos (anterior left, dorsal up) stained with antibody against  $\beta$ -galactosidase ( $\beta$ -gal) show that PRE1 but not PRE2 is able to repress expression of  $\beta$ -gal in the anterior part of the embryos (denoted by the double-headed arrow).

B.  $\beta$ -gal activity stain in salivary glands:  $\beta$ -gal is expressed from the vector alone (no PRE), but is repressed by either PRE1 or PRE2. C. Expression in the larval brain is partially repressed by PRE1 but not by PRE2.

vector, PRE1, but not PRE2, is able to repress expression in the anterior part of the embryo, an indication of PRE activity in this vector (Figure 2A). In contrast, both PREs are able to repress  $\beta$ -galactosidase expression (Figure 2B) and cause the deposition of the H3K27me3 repressive mark over the PRE and *lacZ* gene in salivary glands (Figure 3). However, only PRE1 is able to silence  $\beta$ -galactosidase expression in a subset of cells in the brain (Figure 2C). The data show that PREs are a diverse group of elements that share some but not all activities. Because PREs regulate many different genes, in different tissues and times of development, the differences may be important for the fine-tuning of PcG repression. It is also possible that different PREs recruit different PcG protein complexes. We are currently conducting experiments to test this hypothesis.

## The role of PREs at the *en* gene

The *Drosophila engrailed (en)* gene encodes a homeodomain protein that plays an important role in the development of many parts of the embryo, including formation of the segments, nervous system, head, and gut. By specifying the posterior compartment of each imaginal disk, *en* also plays a significant role in the development of the adult. Accordingly, *en* is expressed in a highly specific and complex manner in the developing organism. The *en* gene exists in a gene complex with an adjacent gene, *invected (inv)*; *inv* encodes a protein with a nearly identical homeodomain, and *en* and *inv* are co-regulated and express proteins with largely redundant functions.

The *en* and *inv* genes exist in a 113kb domain that is covered by the H3K27me3 chromatin mark (Reference 5). Within the *en/inv* domain there are four major PREs, strong peaks of PcG protein binding. One popular model posits that DNA-binding proteins bound to the PREs recruit PcG protein complexes and that PRC2 trimethylates histone H3 throughout the domain until it comes to either an insulator or an actively transcribed gene. As discussed above, there are two PREs upstream of the *en* transcription unit, PRE1 and PRE2. Both PREs reside within a 1.5kb fragment located from -1.9kb to -400bp upstream of the major *en* transcription



**FIGURE 3. PRE1 and PRE2 lead to tri-methylation of histone H3 (H3K27me3) across the *LacZ* reporter gene in transgenic *Drosophila*.**

Chromatin immunoprecipitation with anti-H3K27me3 antibodies on salivary glands from transgenic larvae with vector alone or with vector plus PRE1 or PRE2. A Ubx PRE is used as a positive control. Both PRE1 and PRE2 cause accumulation of the repressive H3K27me3 mark over the transgene.

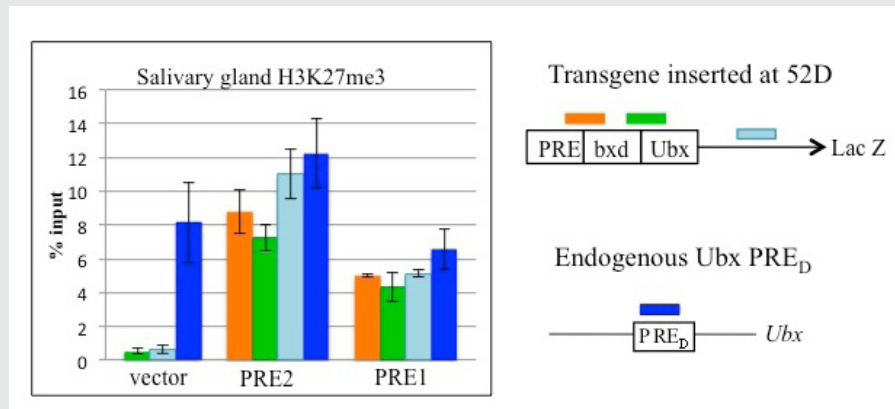

start site. There are also two major *inv* PREs, one located at the promoter and another about 6kb upstream of that. Our laboratory showed that all these PREs have the functional properties attributed to PREs in transgenic assays. To test their function at the intact *en/inv* domain, we set out to delete these PREs from the genome. Given that PREs work as repressive elements, the predicted phenotype of a PRE deletion is a gain-of-function ectopic expression phenotype. Unexpectedly, when we made a 1.5kb deletion removing PRE1 and PRE2, flies were viable and had a partial loss-of-function phenotype in the wing. Similarly, deletion of *inv* PREs yielded viable flies with no mis-expression of *en* or *inv*. Importantly, the H3K27me3 *en/inv* domain is not disrupted in either of these mutants.

In *Drosophila*, PREs are easily recognizable in chromatin-immunoprecipitation experiments as discrete peaks of binding of PcG proteins, but the H3K27me3 mark spreads throughout large regions. PcG proteins are conserved in mammals; however, PcG binding usually does not occur in sharp peaks, and PREs have been much harder to identify. We recently created a chromosome in which both the *en* and *inv* PREs are deleted (Reference 5). Surprisingly, the flies are viable, and there is no mis-expression of *en* or *inv* in embryos or larvae. The question arises as to how PcG proteins are recruited to the *en/inv* domain in the absence of these PREs. We performed chromatin-immunoprecipitation followed by Next-Gen sequencing (ChIP-Seq) on the PcG proteins Pho and Polyhomeotic (Ph). The data showed that, in addition to the large Pho/Ph peaks at the known PREs, there are many smaller Pho/Ph peaks within the *inv/en* domain. Our data show that the peaks may also function as PREs. Thus, rather than a few PREs, there are many PREs controlling *inv/en* expression, and some may act in tissue-specific ways (Reference 5).

## Increasing cohesin binding stability counteracts PcG silencing in *Drosophila*.

Cohesin consists of the proteins Smc1, Smc3, Rad21, and Stromalin (SA) and is important for sister-chromatid cohesion and proper chromosome segregation during mitosis. In addition, cohesin and cohesin-associated proteins play an important role in regulating gene expression. In a recent study, others found that the cohesin subunits Smc1, Smc3, and Rad21 co-purify with the PcG protein Polycomb, suggesting that the protein complexes may physically interact at some loci. Wapl protein regulates binding of the cohesin

FIGURE 4. Wapl-AG causes extra sex comb teeth, the defining feature of PcG mutants.

This *wapl*<sup>AG</sup> pharate adult male has sex comb teeth on all three legs (arrows). The second leg has eight sex comb teeth, and the third leg has two sex comb teeth.

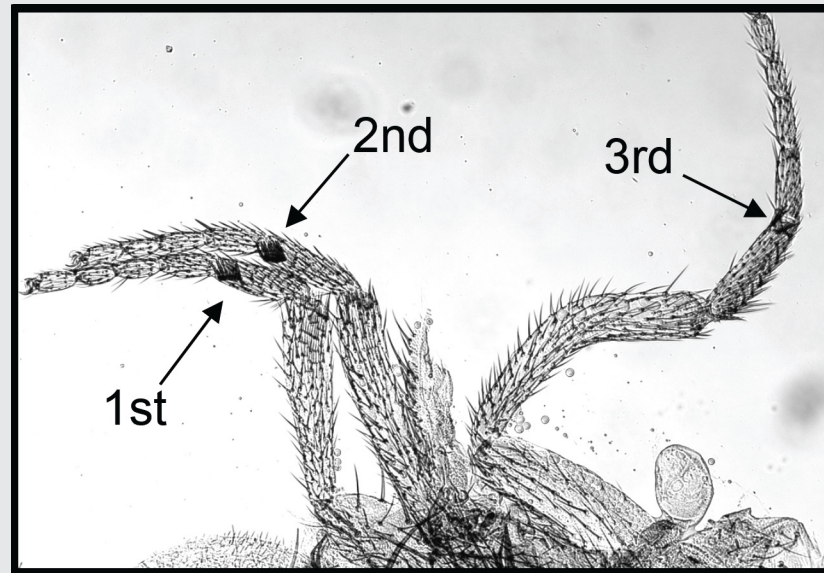

complex to chromosomes during interphase and helps remove cohesin from chromosomes at mitosis. We isolated a dominant mutation in *wapl* (*wapl*<sup>AG</sup>) in a screen for mutations that counteract silencing mediated by an *engrailed* PRE (Reference 1). *wapl*<sup>AG</sup> hemizygotes die as pharate adults and have an extra sex combs phenotype characteristic of males with mutations in PcG genes (Figure 4). The *wapl* gene encodes two proteins, a long form and a short form. *wapl*<sup>AG</sup> introduces a stop codon at amino acid 271 of the long form and produces a truncated protein. The expression of a transgene encoding the truncated Wapl-AG protein causes an extra-sex-comb phenotype similar to that seen in the *wapl*<sup>AG</sup> mutant. Mutations in the cohesin-associated genes *Nipped-B* and *pds5* suppress and enhance *wapl*<sup>AG</sup> phenotypes, respectively. A Pds5-Wapl complex (releasin) removes cohesin from DNA, while Nipped-B loads cohesin, suggesting that Wapl-AG might exert its effects through changes in cohesin binding. Consistent with this model, Wapl-AG was found to increase the stability of cohesin binding to polytene chromosomes. Our data suggest that increasing cohesin stability interferes with PcG silencing at genes that are co-regulated by cohesin and PcG proteins. In collaboration with Karl Pfeifer, we are making a conditional mutant in mouse *Wapl*. We will investigate whether mutations in mouse *Wapl* similarly disrupt PcG-regulated silencing at some loci. Genome-wide studies in *Drosophila* show that cohesin and PRC1 components co-localize at many locations throughout the genome (Reference 2). Functional studies suggest that cohesin binding may control the availability of PRC1 components for gene silencing (Reference 2). Our *Wapl* mouse mutant will provide a valuable reagent to test whether similar PRC1-cohesin interactions are important regulators of gene expression in mammals.

## Enhancer-promoter communication

Enhancers are often located tens or even hundreds of kb away from their promoter, sometimes even closer to promoters of genes other than the one they activate. We showed that *en* enhancers can act over large distances, even skipping over other transcription units, choosing the *en* promoter over those of neighboring genes (Kwon *et al.*, *Development* 2009;136;3067). Such specificity is achieved in at least three ways. First, early-acting *en* stripe enhancers exhibit promoter specificity. Second, a proximal promoter-tethering element is required for the action of the imaginal disk enhancer(s). Our data point to two partially redundant

**FIGURE 5. Enhancers of the *invected* and *engrailed* genes**

A. P-element vector ( $P[en]$ ), used to assay the function of *en* regulatory DNA, contains the *en* promoter, 396bp of upstream sequences, and an untranslated leader fusion between the *en* transcript and the *Adh-lacZ* reporter gene. *inv/en* DNA fragments were added to this vector at the location of the triangle.

B. The extent of each fragment cloned into  $P[en]$  is shown as a black line with a letter above the *inv/en* genomic DNA map (indicated by a long black line with hatch marks at 10kb intervals; numbers are coordinates on

chromosome 2R, genome release v5). Expression pattern in embryos or the wing imaginal disc (wd) are shown above or below the genomic DNA, with arrows pointing to the fragment(s) that generate the pattern (Reference 3).

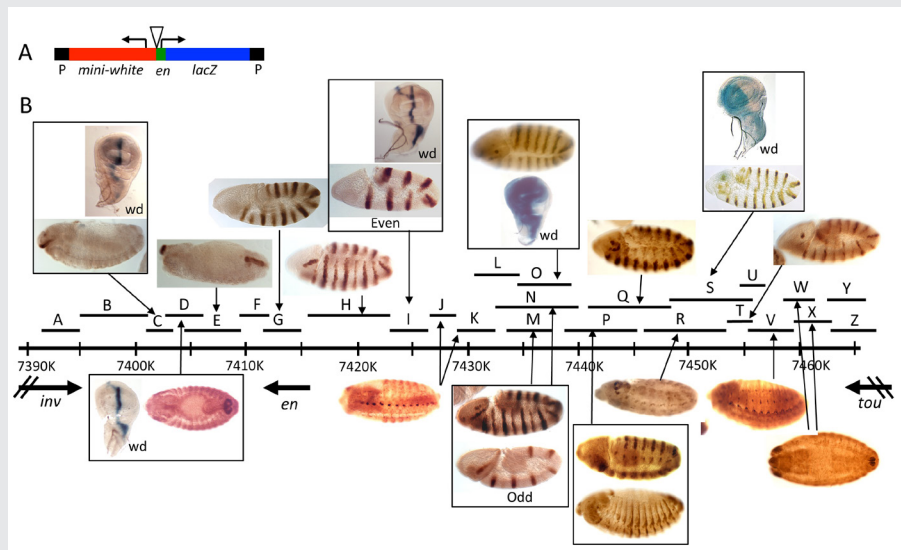

promoter-tethering elements. Third, the long-distance action of *en* enhancers requires a combination of the *en* promoter and sequences within or closely linked to the promoter-proximal PREs. The data show that several mechanisms ensure proper enhancer-promoter specificity at the *Drosophila en* locus, providing one of the first detailed views of how promoter-enhancer specificity is achieved.

As a follow-up to these studies, we located all the enhancers that regulate the transcription of *engrailed* (*en*) and the closely-linked co-regulated gene *invected* (*inv*) (Reference 3). Our dissection of *inv/en*-regulatory DNA showed that most enhancers are spread throughout a 62kb region. We used two types of constructs to analyze the function of this DNA: P-element-based reporter constructs with small pieces of DNA fused to the *en* promoter driving *lacZ* expression (Figure 5); and large constructs with HA-tagged *en* and *inv* inserted in the genome with the phiC31 system. In addition, we generated deletions of *inv* and *en* DNA *in situ* and assayed their effects on *inv/en* expression. Our results support and extend our knowledge of *inv/en* regulation. First, *inv* and *en* share regulatory DNA, most of which is flanking the *en* transcription unit. In support of this finding, a 79-kb *HA-en* transgene can rescue *inv en* double mutants into viable, fertile adults. In contrast, an 84-kb *HA-inv* transgene lacks most of the enhancers for *inv/en* expression. Second, there are multiple enhancers for *inv/en* stripes in embryos; some may be redundant but others play discrete roles at different stages of embryonic development. Finally, no small reporter construct gave expression in the posterior compartment of imaginal discs, a hallmark of *inv/en* expression. Robust expression of *HA-en* in the posterior compartment of imaginal discs is evident from the 79-kb *HA-en* transgene, while a 45-kb *HA-en* transgene gives weaker, variable imaginal disc expression. We suggest that the activity of the imaginal disc enhancer(s) is dependent on the chromatin structure of the *inv/en* domain. We are currently investigating the properties of the *inv/en* imaginal disc enhancer(s) using a variety of methods, including deleting them from the endogenous *inv/en* domain using Crispr/Cas9.

## Publications

1. Cunningham MD, Gause M, Cheng Y, Noyes A, Dorsett D, Kennison JA, Kassis JA. Wapl antagonizes cohesin binding and promotes Polycomb group silencing in *Drosophila*. *Development* 2012 139:4172-4179.
2. Dorsett D, Kassis JA. Check and balances between cohesin and Polycomb in gene silencing and transcription. *Curr Biol* 2014 24:R535-R539.
3. Cheng Y, Brunner AL, Kremer S, DeVido SK, Stefaniuk CM, Kassis JA. Co-regulation of invected and engrailed by a complex array of regulatory sequences in *Drosophila*. *Dev Biol* 2014 395:131-143.
4. Ray P, De S, Mitra A, Bezstarosti K, Demmers JAA, Pfeifer K, Kassis JA. Combgap contributes to recruitment of Polycomb group proteins in *Drosophila*. *Proc Natl Acad Sci USA* 2016 113:3826-3831.
5. De S, Mitra A, Cheng A, Pfeifer Y, Kassis JA. Formation of a Polycomb-domain in the absence of strong Polycomb Response Elements. *PLoS Genetics* 2016 12:e1006200.
6. Lorberbaum et al. An ancient yet flexible cis-regulatory Architecture allows localized Hedgehog tuning by patched/Ptch1. *eLife* 2016 5:e13550.

## Collaborators

- James A. Kennison, PhD, *Section on Drosophila Gene Regulation, NICHD, Bethesda, MD*
- Karl Pfeifer, PhD, *Section on Genomic Imprinting, NICHD, Bethesda, MD*

## Contact

For more information, email [jk14p@nih.gov](mailto:jk14p@nih.gov) or visit <https://irp.nih.gov/pi/judith-kassis>.

## Genomics of Development in *Drosophila*

Our goal is to understand how linear information encoded in genomic DNA functions to control cell fates during development. The *Drosophila* genome is about one twentieth the size of the human genome. However, despite its smaller size, most developmental genes and at least half of the disease- and cancer-causing genes in man are conserved in *Drosophila*, making *Drosophila* an excellent model system for the study of human development and disease. One of the important groups of conserved developmental genes are the homeotic genes. In *Drosophila*, the homeotic genes specify cell identities at both embryonic and adult stages. The genes encode homeodomain-containing transcription factors that control cell fates by regulating the transcription of downstream target genes. The homeotic genes are expressed in precise spatial patterns that are crucial for the proper determination of cell fate. Both loss of expression and ectopic expression in the wrong tissues lead to changes in cell fate. The changes provide powerful assays for identifying the *trans*-acting factors that regulate the homeotic genes and the *cis*-acting sequences through which they act. The *trans*-acting factors are also conserved between *Drosophila* and human and have important functions, not only in development but also in stem-cell maintenance and cancer.

### Cis-acting sequences for transcriptional regulation of the *Sex combs reduced* (*Scr*) homeotic gene

Assays in transgenes in *Drosophila* previously identified *cis*-acting transcriptional regulatory elements from homeotic genes. The assays identified tissue-specific enhancer elements as well as *cis*-regulatory elements that are required for the maintenance of activation or repression throughout development. While these transgenic assays have been important in defining the structure of the *cis*-regulatory elements and identifying *trans*-acting factors that bind to them, their functions within the context of the endogenous genes remain poorly understood. We used a large number of existing chromosomal aberrations in the *Scr* homeotic gene to investigate the functions of the *cis*-acting elements within the endogenous gene. The chromosomal aberrations identified an imaginal leg enhancer about 35 kb upstream of the *Scr* promoter. The enhancer is not only able to

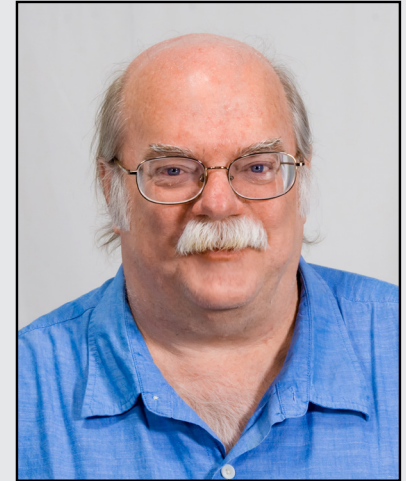

**James A. Kennison, PhD, Head,**  
*Section on Drosophila Gene Regulation*

Monica T. Cooper, BA, *Senior Research Technician*

Jasmine Wong, BA,  
*Postbaccalaureate Fellow*

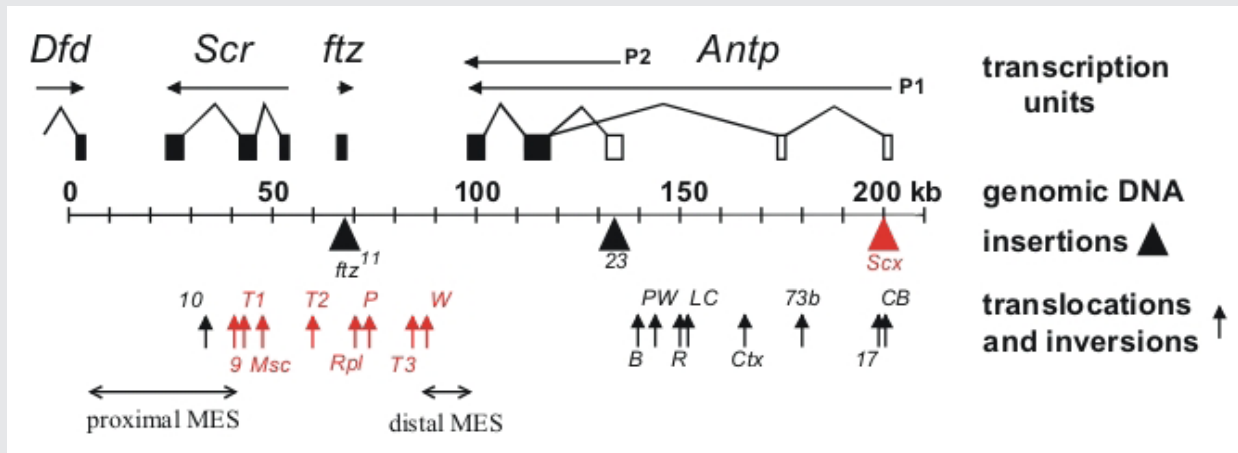
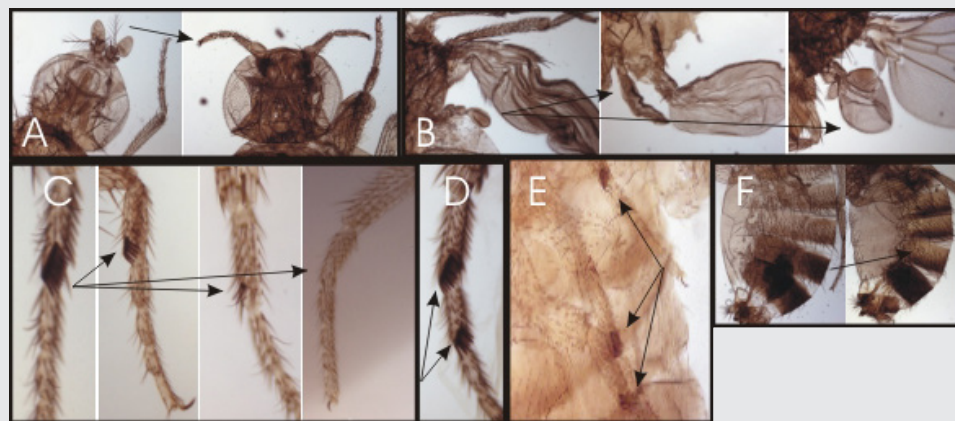

FIGURE 1. Chromosomal aberrations in the distal half of the *Antennapedia* complex

The transcription units are shown above the genomic DNA, while chromosomal aberrations are shown below (solid triangles indicate insertions of transposable elements and upward arrows indicate breakpoints of translocations and inversions). Chromosomal aberrations (red) interfere with silencing in the adult second and third legs. The regions that include the proximal and distal MES are indicated by horizontal arrows.

activate transcription of the *Scr* promoter that is 35 kb distant but can also activate transcription of the *Scr* promoter on the homologous chromosome. Although the imaginal leg enhancer can activate transcription in all three pairs of legs, it is normally silenced in the second and third pairs of legs. The silencing requires the Polycomb-group proteins. We are currently attempting to identify the *cis*-regulatory DNA sequences in the *Scr* that are required for Polycomb-group silencing in the second and third legs. Characterization of

FIGURE 2. Homeotic phenotypes of new pharate-adult lethal mutants



- A) Wild-type on the left and the transformation of aristae to distal leg on the right.
- B) Wild-type haltere on the left and transformations of anterior and posterior haltere to anterior and posterior wing in the middle and right, respectively.
- C) First legs from a wild-type male on the left and three different mutants with reduced sex combs on the right.
- D) Mutant male with sex combs on both the first and second tarsal segments.
- E) Mutant male with sex combs on all three pairs of legs.
- F) Abdominal segments from a wild-type male on the left; mutant male with transformation of the fifth abdominal segment to a more anterior identity on the right.

**FIGURE 3. Genetic screen for new mutations that disrupt pairing-sensitive silencing**

Flies homozygous for transposons carrying the *mini-white* reporter gene and a pairing-sensitive silencing element have white eyes. Clones of cells homozygous for newly induced mutants are generated using the yeast site-specific recombinase (FLP recombinase) and its target site (FRT). The clones of mutant cells are able to express the *mini-white* reporter gene and are pigmented (shown in the eye on the right of the figure).

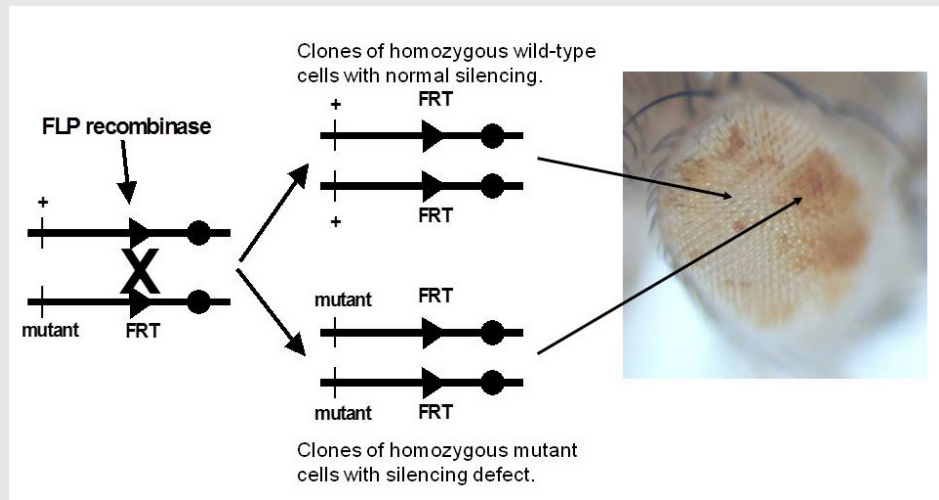

the chromosomal rearrangements shown in Figure 1 also revealed that two genetic elements (proximal and distal MES [maintenance elements for silencing]), about 70 kb apart in the *Scr* gene, must be in *cis* to maintain proper repression. When not physically linked, the elements interact with elements on the homologous chromosome and cause derepression of its wild-type *Scr* gene. Using a transgenic assay, we identified at least five DNA fragments from the *Scr* gene that silence transcription from a reporter gene. The transcriptional silencers are clustered in the two regions whose interactions are required for the maintenance of silencing in the endogenous genes. We also use the silencer elements to screen for mutations in *trans*-acting silencing factors.

## Trans-acting activators and repressors of homeotic genes

The initial domains of homeotic gene repression are set by the segmentation proteins, which also divide the embryo into segments. Genetic studies identified the trithorax group of genes that are required for expression or function (such as maintenance of transcriptional activation) of the homeotic genes. Maintenance of transcriptional repression requires the proteins encoded by the Polycomb-group genes. To identify new trithorax-group activators and Polycomb-group repressors, we screened for new mutations that mimicked the following phenotypes: loss of function or ectopic expression of the homeotic genes. We generated over 4,000 lethal mutants and, among those that die late in development, identified two dozen mutants with homeotic phenotypes. Some of the homeotic phenotypes are shown in Figure 2. The mutants identify genes required for expression or function of the homeotic genes.

We also use Polycomb-group response elements from the *Scr* gene to screen for recessive Polycomb-group mutations. Transgenes with a Polycomb-group response element and a reporter gene (the *Drosophila mini-white* gene) exhibit reporter gene expression in flies heterozygous for the transgene, but reporter gene expression is repressed in flies homozygous for the transgene. In flies homozygous for transgenes with the *mini-white* reporter gene silenced by the Polycomb-group response elements, we generate clones of cells in the eye that are homozygous for newly induced mutations, using the yeast FLP/FRT site-specific recombination system (Figure 3). Silencing mutations are detected by the appearance of pigmented spots

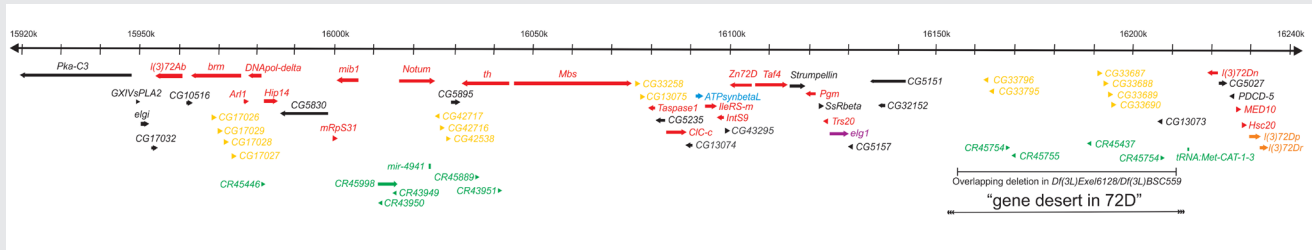

FIGURE 4. Molecular map of the genomic region deleted in *Df(3L)th102* (polytene region 72A-D)

The approximately 320 kb of genomic DNA (from 3L: 15918k to 16240k, Release 5.23) is represented by the horizontal black arrow at the top. The annotated transcription units are represented by colored thick horizontal arrows. Transcription units essential for viability are red and orange. Transcription units essential only for male fertility are blue and the transcription unit required for female fertility is purple. The clusters of transcription units encoding related proteins are yellow and orange [the *I(3)72Dp* and *I(3)72Dr* genes essential for viability]. The remaining protein-coding genes are black, and the tRNAs, mirRNAs, and non-coding RNAs are green. The non-essential DNA missing in flies *trans-heterozygous* for the overlapping deletions *Df(3L)Exel6128* and *Df(3L)BSC559* and the putative “gene desert” are indicated by the horizontal black bars at the bottom.

in the white-eyed flies (cells that derepress the silenced *mini-white* reporter gene). We screened about 98% of the genome and recovered 342 new silencing mutants. About one third of the new mutants do not carry a new silencing mutation but bear chromosome aberrations that generate aneuploid cells after mitotic recombination. The aneuploid regions include the reporter transgene and they disrupt silencing by changing copy number. Although the mutants do not identify new genes, the phenomenon that we discovered will be very useful for detecting chromosomal aberrations in F1 mutant screens. The remaining two thirds of our mutants are not associated with large chromosomal aberrations and carry mutations in genes required for Polycomb-group transcriptional silencing. Seventy-seven mutations are in 14 known Polycomb-group genes. The remaining mutations identify 61 additional genes required for silencing. For 44 of these genes, we identified the corresponding transcription units using a combination of meiotic recombination mapping and whole-genome sequencing. The new silencing genes include DNA-binding proteins, chromatin-remodeling factors, and insulator proteins.

## Structure and function of the *Drosophila* genome

The *Drosophila melanogaster* genome has been intensely studied for over 100 years. Recently, sequencing of the majority of the genomic DNA revealed much about the structure and organization of the genome. Despite those molecular advances, much remains to be discovered about the functions encoded within the genome. As part of a long-term project to understand the function and organization of the *Drosophila* genome, we set out to identify all genes essential for viability or male fertility in two regions of the genome that span almost 1 megabase of DNA (shown in Figures 4 and 5). We identified 10 gene clusters that appear to have arisen by tandem duplication. The clusters include 34 of the 137 predicted genes. We identified 47 genes essential for zygotic viability, including two of the pairs of tandemly duplicated genes. We identified the transcription units corresponding to all genes essential for viability. We also identified eight genes that are required only for fertility, most of which are male-specific in expression. The transcription units corresponding to all the genes required for fertility have been identified. With the exception of the *Antennapedia* and *bithorax* homeotic gene complexes, for no other regions of the *Drosophila* genome have



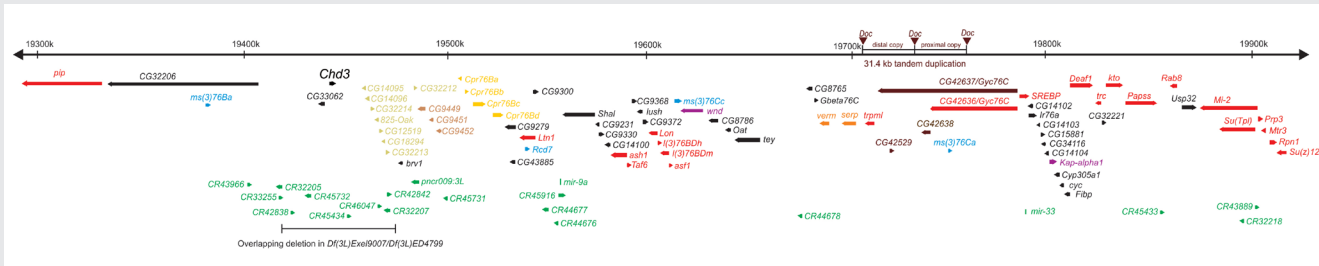

FIGURE 5. Molecular map of the genomic region deleted in *Df(3L)kto2* (polytene region 76B-D)

The approximately 640 kb of genomic DNA (from 3L: 19291k to 19926k, Release 5.23) is represented by the horizontal black arrow at the top. The annotated transcription units are represented by colored thick horizontal arrows. Transcription units essential for viability are red and orange. Transcription units essential only for fertility are blue (male-specific) and purple (both sexes). The clusters of transcription units encoding related proteins are gold, brown, and orange (the *verm* and *serp* genes essential for viability). The remaining protein-coding genes are black, and the tRNAs, mirRNAs, and non-coding RNAs are green. A 31.4 kb tandem duplication (distal copy and proximal copy) flanked by *Doc* transposable elements in the sequenced *iso-1* strain (but not in other wild-type strains) is shown on the genomic DNA, with the *Doc* elements represented by inverted brown triangles. The non-essential DNA missing in flies *trans*-heterozygous for the overlapping deletions *Df(3L)Exel9007* and *Df(3L)ED4799* is indicated by the horizontal black bar at the bottom.

transcription units essential for viability and fertility been as completely analyzed.

We were also able to assess the progress of the *Drosophila* Gene Disruption Project. While the project has tagged about two-thirds of the annotated genes with transposon insertions, the insertions disrupt the function of only 45% of the genes. Our analysis of data from the *Drosophila* modENCODE project suggests that 20% or more of the genome is expressed only in males, consistent with the observations that male-sterile mutations are recovered at almost 15% the frequency of lethal mutations. In contrast, only about 1–2% of the genome is expressed only in females.

Surprisingly, when we deleted a genomic region that spanned 55 kb, we found no effects on either viability or fertility. Although this nonessential region includes seven predicted genes, there is no evidence that the genes are expressed under any known conditions. The seven predicted genes are also not evolutionarily conserved. While there are no evolutionarily conserved open reading frames within this gene desert, the region has 48 DNA sequences of between 12 and 33 base pairs that are each identical in 12 different *Drosophila* species. The strong conservation indicates that the sequences must have some function that is beneficial to flies living outside the laboratory.

## Publications

1. Monribot-Villanueva J, Juarez-Urbe RA, Palomera-Sanchez Z, Gutierrez-Aguilar L, Zurita M, Kennison JA, Vazquez M. TnaA, an SP-RING protein, interacts with Osa, a subunit of the chromatin remodeling complex BRAHMA and with the SUMO pathway in *Drosophila melanogaster*. *PLoS One* 2013 8:e62251.
2. Lindsley DL, Roote J, Kennison JA. Anent the genomics of spermatogenesis in *Drosophila melanogaster*. *PLoS One* 2013 8:e55915.

3. Gilliland WD, May DP, Colwell EM, Kennison JA. A simplified strategy for introducing genetic variants into *Drosophila* compound autosome stocks. *G3* 2016 in press

## Collaborators

- William Gilliland, PhD, *DePaul University, Chicago, IL*
- Judith Kassis, PhD, *Section on Gene Expression, NICHD, Bethesda, MD*
- Dan Lindsley, PhD, *University of California San Diego, La Jolla, CA*
- Martha Vazquez, PhD, *Instituto de Biotecnología, UNAM, Cuernavaca, Mexico*
- Mario Zurita, PhD, *Instituto de Biotecnología, UNAM, Cuernavaca, Mexico*

## Contact

For more information, email [kennisoj@mail.nih.gov](mailto:kennisoj@mail.nih.gov) or visit <https://irp.nih.gov/pi/james-kennison>.

## Assembly and Function of *Drosophila* Chromatic Circuits

Using the *Drosophila* visual system as a model, we study how neurons form complex yet stereotyped synaptic connections during development and how the assembled neural circuits extract visual attributes, such as color and motion, to guide animal behaviors. To study visual circuit functions, we combine structural and functional approaches to map visual circuits. By targeted manipulation of neuronal activity, we identified specific neurons that are functionally required for color-driven behaviors. Using both light- and electron-microscopy (EM) studies, we mapped the neuron's synaptic circuits. For circuit development, we focus on the formation of synaptic connections between the chromatic photoreceptors and their synaptic partners in the medulla neuropil. We used high-resolution imaging techniques and genetic manipulations to delineate the molecular mechanisms that control dendritic patterning and synaptic specificity of the medulla neurons.

### Mapping color-vision circuits

Visual animals utilize spectral information in two ways: true color vision, which differentiates spectral compositions largely independently of brightness, allows animals to recognize objects and register and retrieve color memory; innate spectral preference, which is intensity-dependent and learning-independent, reflects individual species' specific ecological needs. Using a combination of genetic, histological, electrophysiological, imaging, and behavioral approaches, we study how visual circuits process chromatic information to guide behaviors in *Drosophila*. Our strategy is to 1) identify key neuronal types and to map their synaptic connections, 2) examine the functional requirement of identified neurons for color vision and spectral preference behaviors, and 3) determine the synaptic mechanism that transform visual signals at different processing stages.

Using molecular genetics and histology, we mapped the synaptic circuits of the chromatic photoreceptors R7 and R8 and their synaptic target neurons, the Tm and Dm neurons, in the peripheral visual system. The medulla projection (Tm) neurons (Tm5a/b/c, Tm9, and Tm20), which are analogous to vertebrate retinal ganglion cells, relay photoreceptors to higher visual centers, while the Dm (Dm8) neurons

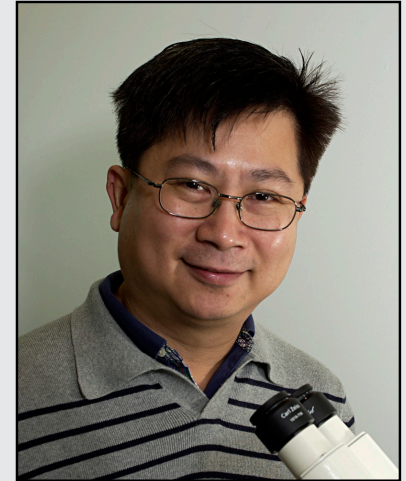

**Chi-Hon Lee, MD, PhD, Head,**  
*Section on Neuronal Connectivity*  
**Chun-Yuan Ting, PhD, Staff**  
*Scientist*

**Yang Li, PhD, Visiting Fellow**  
**Jiangnan Luo, PhD, Visiting Fellow**  
**Pushpanathan Muthurulan, PhD,**  
*Visiting Fellow*

**Bo-mi Song, PhD, Intramural**  
*Research Training Award Fellow*

**Bo Shi, MSc, Graduate Student**

**Moyi Li, BA, Biological Laboratory**  
*Technician*

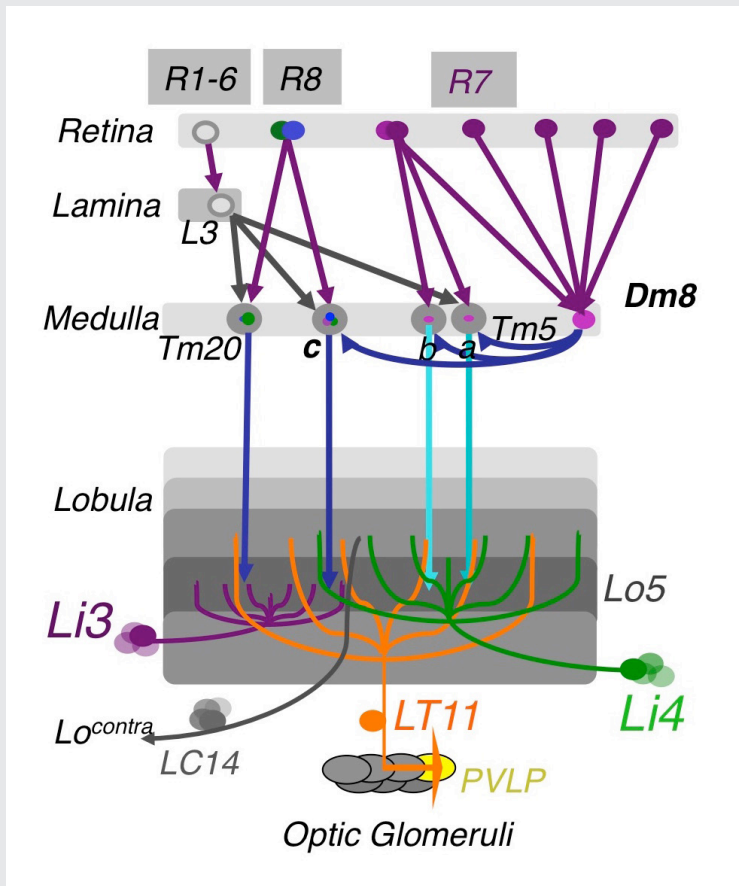

**FIGURE 1.** The chromatic circuit in *Drosophila*

Fly vision is mediated by three types of photoreceptors, R1–6, R7, and R8, each responding to a specific spectrum of light and connecting to different synaptic partners in the lamina and medulla neuropils. The chromatic photoreceptors R7 and R8 provide inputs for the amacrine neuron Dm8 and the transmedulla neurons Tm5a/b/c and Tm20. The transmedulla neurons transmit visual signals to four types of lobular neurons, LT11, LC14, Li3, and Li4, in the higher visual center.

provide an indirect pathway by relaying photoreceptors to Tm neurons. To probe the synaptic connections between these identified neurons, we developed two modified versions of the GRASP (GFP reconstitution across synaptic partners) method: an activity-dependent GRASP based on split GFP–tethered synaptic proteins and a receptor-based GRASP based on split GFP–tethered neurotransmitter receptors. Using these methods, we found that the chromatic photoreceptors R7 (UV-sensing) and R8 (blue/green-sensing) provide inputs to a subset of first-order interneurons. Tm9/20/5c and Tm5a/b receive direct synaptic inputs from retinotopic R8s and R7s, respectively, consistent with their functions in processing single visual pixel information. In contrast, the amacrine neuron Dm8 pools inputs from 14 R7s and provides input for Tm5c.

To assign neurons to innate spectral preference, we systematically inactivated different first-order interneurons and examined behavioral consequences. We had previously found that the amacrine Dm8 neurons, which receive UV-sensing R7 photoreceptor inputs, are both required and sufficient for animals' innate spectral preference to UV light. We further found that inactivating Tm5c, one of Dm8's synaptic targets, abolished UV preference, indicating that Tm5c is the key downstream target for spectral preference. Both single-cell transcript profiling and immuno-histochemistry revealed that both Dm8 and Tm5c express the vesicular glutamate transporter (VGlut). RNAi knockdown of VGlut in Dm8 or Tm5c significantly reduced UV preference, suggesting the critical functions of the glutamatergic output of Dm8 and Tm5c. We further showed that Tm5c expresses four kainite-type glutamate receptors and that RNAi knockdown of these

receptors, which prevents Tm5c from receiving Dm8 inputs, significantly reduced UV preference. Thus, the R7s→Dm8→Tm5c connections constitute a hard-wired glutamatergic circuit for detecting dim UV light. Two-photon calcium imaging of Dm8 and Tm5c expressing the calcium indicator GCaMP6f revealed that the activity of both neurons is suppressed by full-field UV light illumination. The light responses of Dm8 are dependent on R7's activity and Dm8's expression of the histamine chloride channel ORT, indicating that Dm8 conveys sign-inverted signal via ORT.

In contrast to UV preference, color vision in flies appears to be mediated by several partially redundant pathways. To identify color-vision circuits, we developed a novel aversive operant conditioning assay for intensity-independent color discrimination. We conditioned single flies to discriminate between equi-luminant blue or green stimuli. We found that wild-type flies can be trained to avoid either blue or green whereas mutants lacking functional R7 and R8 photoreceptors cannot, indicating that color entrainment requires the function of the narrow-spectrum photoreceptors R7s and/or R8s. Inactivating four types of first-order interneurons, Tm5a/b/c and Tm20, abolishes color learning, whereas inactivating different subsets of these neurons is insufficient to block color learning, suggesting that true color vision is mediated by parallel pathways with redundant functions. The apparent redundancy in learned color discrimination sharply contrasts with innate spectral preference, which is dominated by a single pathway, R7s→Dm8→Tm5c.

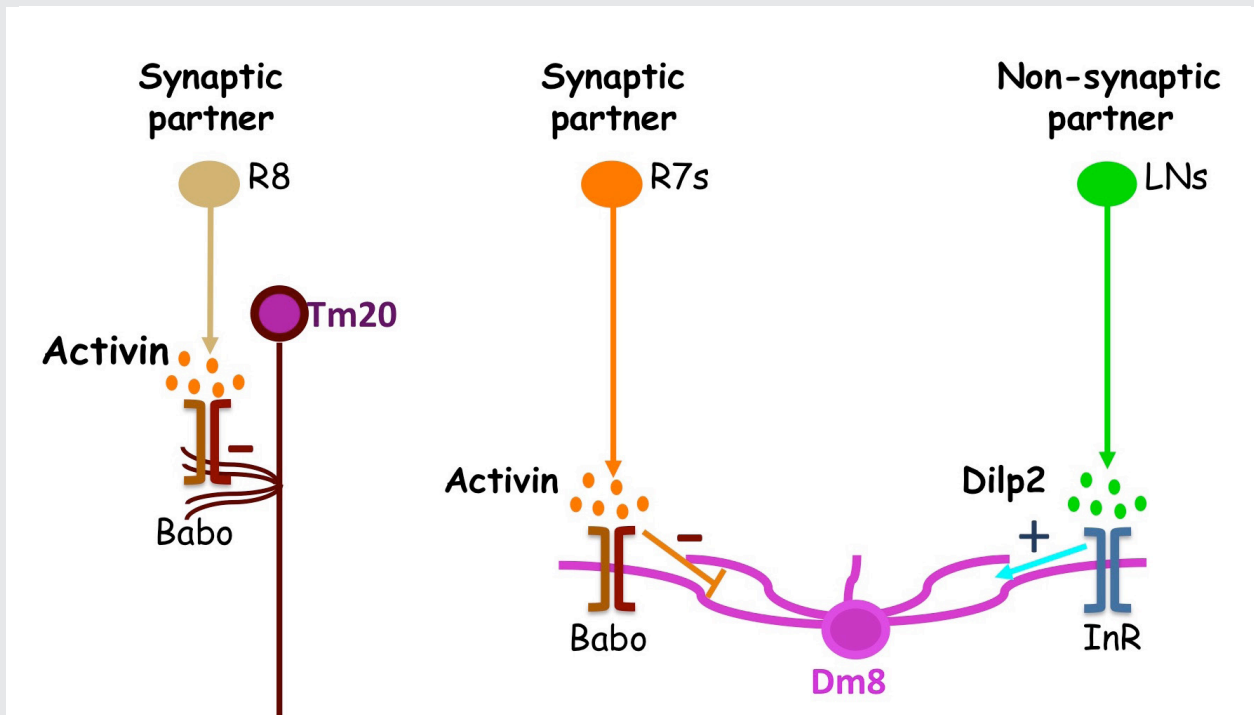

FIGURE 2. Afferent-derived factors act in parallel pathways to regulate dendritic field sizes.

Two afferent-derived factors, Activin and *Drosophila* insulin-like peptide2 (Dilp2), signal on the first-order interneurons, Tm20 and Dm8, to control the sizes of their dendritic fields. Activin is provided by R7 and R8 photoreceptors, the synaptic partners of Tm20 and Dm8, respectively. Dilp2, on the other hand, is provided by lamina neurons (LNs), non-synaptic partners of Dm8. Babo, Baboon (activin receptor); InR, insulin receptor.

The Tm5a/b/c and Tm20 neurons relay photoreceptor signals to the higher visual center, the lobula, which in insects has been implicated in processing and relaying color information to the central brain. To determine how color information is processed in the higher visual center, we set out to identify the lobula neurons that receive direct synaptic inputs from the chromatic Tm neurons Tm5a/b/c and Tm20. We first collected and characterized 28 Gal4 lines for their expression in various lobula neurons. Second, we used our modified GRASP method to examine potential contacts between chromatic Tm neurons and the dendrites of candidate lobula neurons. We identified four types of lobula neuron that form synaptic contacts with chromatic Tm neurons: two novel lobula intrinsic neurons, Li3 and Li4, and two lobula projection neurons, LT11 and LC14. Each LT11 elaborates a large dendritic tree to cover the entire lobula layers Lo4-6 and projects an axon to optic glomeruli in the central brain. Each Li4 extends dendrites to cover about 60% of the lobula layer Lo5, while each Li3's dendrites cover about 15% of the lobular layers 5 and 6. Using the single-cell GRASP method we had developed, we further characterized the synaptic connections at the single-cell resolution and found that both Li4 and LT11 neurons receive inputs from all four chromatic Tm neurons but that LT11 appears to prefer Tm5a neurons. To confirm synaptic connections observed at the light microscopic level, we developed, for EM analysis, a two-tag EM double-labeling technique that highlights both presynaptic and postsynaptic terminals in the same preparation. By combining two orthogonal expression systems and two different peroxidases, HRP (horse radish peroxidase) and APX (ascorbate peroxidase), we expressed mitochondrion-targeted APX in Tm5c and membrane-tethered HRP in their postsynaptic neurons LT11 and confirmed appositions among synaptic profiles. Our anatomical study suggests that the lobula neurons integrate multiple chromatic inputs from Tm neurons over a large receptive field.

## Dendritic development of *Drosophila* optic lobe neurons

Wiring brains requires routing axons and dendrites to appropriate regions, such as layers and columns, to form correct synaptic connections during development. Many neuropsychiatric disorders, such as Down syndrome, Fragile X syndrome, and Rett syndrome, have development origins and exhibit abnormal dendritic morphological defects, such as changes in branching numbers and patterns. Dendritic defects could cause neuronal connectivity defects, which likely underlie neurological and cognitive deficits. It remains unclear, however, how genetic disorders lead to dendritic patterning defects during development, resulting in erroneous connections and functional deficits in adults.

In this project, we use *Drosophila* optic lobe neurons as a model to study dendrite development and neural circuit assembly in the central nervous system. Like the vertebrate cortex and retina, the *Drosophila* optic lobe is organized in columns and layers, suggesting that the fly visual neurons and vertebrate cortex neurons face similar challenges in routing their dendrites to specific layers and columns during development. In addition, the *Drosophila* visual system has several unique advantages: 1) the medulla neurons extend dendritic arbors in a lattice-like structure, facilitating morphometric analysis; 2) the synaptic partnership is known; 3) genetic tools for labeling specific classes of medulla neurons and determining their connectivity are available; 4) sensitive behavioral assays are available for quantifying functional deficits. To analyze the dendritic patterns of the medulla neurons, we developed several techniques: (a) a dual-imaging technique for high-resolution imaging; (b) a registration technique to standardize and to compare dendritic patterns; (c) two modified GRASP methods for visualizing synaptic connections at the light-microscopic level; (d) a two-tag dual-labeling method for examining synapses at the electron microscopic level.

Using these techniques, we first analyzed the dendritic morphologies of four types of medulla neurons,

Tm1, Tm2, Tm9 and Tm20. We identified four dendritic attributes: (i) layer-specific dendritic initiation, (ii) planar projection direction, (iii) layer-specific dendritic termination, and (iv) type-specific size of dendritic receptive field. (i) For Tm1/2/9/20, most dendritic branches (over 75%) originate from one or two primary branching nodes on the axons in the medulla M2/3 layers, while the other Tm neurons, such as Tm5a/b, initiate their dendrites in the M5/6 layers. (ii) Tm1/2/9 project their dendrites anteriorly to innervate their cognate columns while Tm20 dendrites project posteriorly. (iii) Tm1/2/9/20 project dendrites to terminate in specific layers in a type-specific fashion that matches their presynaptic partners. (iv) The dendrites of four types of Tm neurons are largely confined in single medulla columns while the amacrine neurons Dm8 extend a large dendritic tree to cover about 14 medulla columns. By clustering analyses using either PCA (principle component analysis) or an information-theory-based t-SNE (t-distributed stochastic neighboring embedding) algorithm, we found that layer-specific distribution of dendritic terminals and planar projection directions are the most important type-specific attributes and are sufficient to differentiate the Tm neurons. In sharp contrast, standard morphometric parameters, such as branch numbers and bifurcation topologies, are similar among these Tm neurons, and these parameters are thus incapable of differentiating Tm neurons dendritic patterns.

To determine the molecular mechanisms controlling dendritic patterning during development, we carried out genetic screens for morphological defects in Tm20 and Dm8 dendrites. We identified adhesion receptors, morphogen receptors, signaling molecules, and cytoskeletal regulators that are cell-autonomously required in Tm20 or Dm8 neurons for proper dendritic development. In particular, the classical cadherin N-cadherin is required in Tm20 neurons for layer-specific initiation of main dendritic branching points. Unlike wild-type Tm20 neurons, which extended most dendritic branches from one or two primary branching nodes located in the medulla M3 layer, *Ncad*-mutant Tm20 neurons shifted the main dendritic nodes to the M2 layers. The layer shift of the main branching nodes in *Ncad*-mutant Tm20 neurons correlates with an alteration of layer-specific targeting of their dendritic arbors and, to some degree, their planar projection direction. Interestingly, the total dendritic length was unaffected, suggesting that *Ncad* mutation specifically affects the initiation of primary dendritic branches rather than branch trimming.

We identified two pathways that regulate the sizes of dendritic trees. We found that the TGF-beta/Activin signaling pathway negatively controls the sizes of the dendritic fields of Tm20 and Dm8. Mutant Tm20 lacking Activin signaling components, such as the receptor Baboon or the downstream transcription factor Smad2, elaborated an expanded dendritic tree, spanning several medulla columns. Morphometric analyses based on a Kaplan-Meier non-parametric estimator further showed that *baboon* and *smad2* mutations significantly reduce dendritic termination frequency. Using a modified GRASP method, we found that the expanded dendritic tree of mutant Tm20 neurons forms aberrant synaptic contacts with several neighboring R8 photoreceptors. In contrast, wild-type Tm20 neurons form synaptic connections with single R8 photoreceptors in their cognate columns. RNAi-mediated knockdown of Activin in R7s and R8s caused an abnormal expansion of dendritic fields of Dm8 and Tm20 neurons, respectively. The results indicate that the photoreceptors R7 and R8 provide Activin specifically for their respective synaptic targets, Dm8 and Tm20. Conversely, we found that the insulin signaling pathway positively regulates the dendritic tree size of the Dm8 but not that of the Tm20 neuron. Mutant Dm8 neurons lacking insulin receptor or the downstream signaling components TOR (target of rapamycin) or Rheb (a GTPase) have a small dendritic tree while mutant Dm8 neurons lacking the negative regulators of the insulin signaling pathway, Pten (Phosphatase and tensin homolog) or TSC1 (Tuberous Sclerosis 1), have an expanded dendritic tree, as compared with the

wild-type. Mutations in TOR-regulatory genes, such as *TSC1/2* and *AKT*, have been associated with several focal malformations of cortical development (MCD) subtypes connected with epilepsy, collectively called mTORopathies. The Dm8 system we developed allows dissection of the complex phenotypes of the TOR pathway at single-cell resolution, as well as the segregation of developmental and compensatory effects.

## Additional Funding

- NIH Exploratory/Developmental Research Grant

## Publications

1. Li Y, Dharkar P, Han T-H, Serpe M, Lee C-H, Mayer ML. Novel functional properties of Drosophila CNS glutamate receptors. *Neuron* 2016; Epub ahead of print.
2. Lin T-Y, Luo J, Shinomiya K, Ting C-Y, Lu Z, Meinertzhagen IA, Lee C-H. Mapping chromatic pathways in the Drosophila visual system. *J Comp Neurol* 2016 524:213-227.
3. Luo J, McQueen PG, Shi B, Lee C-H, Ting C-Y. Wiring dendrites in layers and columns. *J Neurogenet* 2016 30:69-79.
4. Kulkarni A, Ertekin D, Lee C-H, Hummel T. Birth order dependent growth cone segregation determines synaptic layer identity in the Drosophila visual system. *eLife* 2016 5:e13715.
5. Macpherson LJ, Kearney PJ, Zaharieva EE, Lin T-Y, Turan Z, Lee C-H, Gallio M. Dynamic, multiple-color labeling of neural connections by trans-synaptic fluorescence complementation. *Nat Commun* 2015 6:10024.

## Collaborators

- Dion Dickman, PhD, *University of Southern California, Los Angeles, CA*
- Marco Gallio, PhD, *Northwestern University, Evanston, IL*
- Mary Lilly, PhD, *Section on Gamete Development, NICHD, Bethesda, MD*
- Mark Mayer, PhD, *Laboratory of Cellular and Molecular Neurophysiology, NICHD, Bethesda, MD*
- Matthew McAuliffe, PhD, *Division of Biomedical Imaging Research Services Section, CIT, NIH, Bethesda, MD*
- Philip McQueen, PhD, *Mathematical and Statistical Computing Laboratory, CIT, NIH, Bethesda, MD*
- Ian Meinertzhagen, PhD, DSc, *Dalhousie University, Halifax, Canada*
- Kate O'Connor-Giles, PhD, *University of Wisconsin, Madison, WI*
- Nishith Pandya, BA, *Division of Biomedical Imaging Research Services Section, CIT, NIH, Bethesda, MD*
- Thomas Pohida, MSEE, *Division of Computational Bioscience, CIT, NIH, Bethesda, MD*
- Randy Pursley, MSEE, *Division of Computational Bioscience, CIT, NIH, Bethesda, MD*
- Mihaela Serpe, PhD, *Unit on Cellular Communication, NICHD, Bethesda, MD*
- Mark Stopfer, PhD, *Section on Sensory Coding and Neural Ensembles, NICHD, Bethesda, MD*
- Benjamin White, PhD, *Laboratory of Molecular Biology, NIMH, Bethesda, MD*

## Contact

For more information, email [leechih@mail.nih.gov](mailto:leechih@mail.nih.gov) or visit <http://unc.nichd.nih.gov>.



## Extracellular Matrix Disorders: Molecular Mechanisms and Treatment Targets

The extracellular matrix (ECM) is involved in a wide variety of disorders, ranging from rare genetic abnormalities of skeletal development (skeletal dysplasias) to such common ailments as osteoporosis, fibrosis, and cancer. Our interest in ECM biology began with studies on basic principles relating the helical structure of collagen and DNA to their interactions and biological function. Over the years, the focus of our research shifted to collagens, which are the most abundant ECM molecules, and then to ECM disorders and the development of novel treatments for these disorders. We gradually phased out DNA studies and concentrated on ECM pathology in cancer, fibrosis, osteogenesis imperfecta (OI), Ehlers-Danlos syndrome (EDS), chondrodysplasias, osteoporosis, and other diseases. Together with other NICHD and extramural clinical scientists, we strive to improve our knowledge of the molecular mechanisms underlying those diseases. We hope to use the knowledge gained through our studies for diagnostics, characterization, and treatment, bringing our expertise in physical biochemistry and theory to clinical research and practice.

### Procollagen folding and its role in bone disorders

Collagens are triple-helical proteins forming the structural scaffolds of many tissues and organs. Type I collagen produced by osteoblasts is the main structural component of the organic bone matrix. By far the most abundant protein in all vertebrates, type I collagen accounts for up to 30% of all proteins synthesized by osteoblasts. Yet, folding of its procollagen precursor within the endoplasmic reticulum (ER) presents an extraordinary challenge for cells. We discovered that the thermodynamically favorable state of type I procollagen at body temperature is a random coil. The natively folded procollagen conformation is more favorable and therefore stable only below 35°C. To fold procollagen at body temperature, cells use the collagen-specific molecular chaperone HSP47 and possibly other specialized ER chaperones to stabilize the native conformation. Outside the cell, the native conformation is stabilized after procollagen is converted to collagen and incorporated into collagen fibrils. Unincorporated molecules denature within several hours after secretion and become susceptible to rapid proteolytic degradation. Our findings indicate



**Sergey Leikin, PhD, Head, Section on Physical Biochemistry**

Elena N. Makareeva, PhD, *Staff Scientist*

Edward L. Mertz, PhD, *Staff Scientist*

Shakib Omari, PhD, *Postdoctoral Fellow*

Anna Roberts-Pilgrim, PhD, *Postdoctoral Fellow*

Laura Gorrell, BS, *Predoctoral Fellow*

Katrina Y. Koon, BS, *Postbaccalaureate Fellow*

that osteoblast malfunction caused by procollagen misfolding is an important factor in bone pathology (Reference 1).

The most common hereditary cause of procollagen misfolding is a Gly substitution anywhere in the obligatory (Gly-X-Y)<sub>n</sub> sequence of the collagen triple helix. Such substitutions are responsible for over 80% of severe OI cases. Our studies of OI patients with over 50 different Gly substitutions revealed several structural regions within the triple helix where these mutations might be responsible for distinct OI phenotypes. For example, the first 85–90 amino acids at the N-terminal end of the triple helix form an “N-anchor” domain with higher than average triple helix stability. Gly substitutions within this region disrupt the whole N-anchor, preventing normal cleavage of the adjacent N-propeptide. Incorporation of collagen with uncleaved N-propeptides into fibrils leads to hyperextensibility and joint laxity more characteristic of the Ehlers-Danlos syndrome (EDS). Gly substitutions in alpha1(I) within another region, one that surrounds the collagenase cleavage site, might be lethal because the sequence of this region prevents efficient renucleation of normal C-to-N-terminus helix folding, once the mutation is encountered.

Bone pathology associated with excessive procollagen misfolding of nonhereditary origin is likely to be more prevalent than OI. Indeed, our data suggest that such misfolding should occur upon changes in the osteoblast ER environment associated with aging, environmental factors, inflammation, etc. It is likely to contribute to age-related osteoporosis, bone loss during cancer treatment, and many other common ailments. However, almost nothing is known about this pathophysiology mechanism because procollagen folding and consequences of its misfolding for the cell remain poorly understood.

## Cell biology of procollagen misfolding

To better understand the fundamental cell biology of procollagen misfolding, we are using live-cell imaging to investigate synthesis, folding, trafficking, and degradation of fluorescently tagged procollagen in osteoblasts. Our study of transiently transfected chains produced several surprises. In particular, live-cell imaging revealed no HSP47 in vesicles shuttling procollagen from the ER to Golgi or in autophagosomes containing misfolded procollagen, contrary to the existing hypotheses. Given that HSP47 preferentially binds to the natively folded triple helix, bound HSP47 has been presumed to be involved in quality control and export of properly folded procollagen from the ER. If confirmed, our finding that HSP47 is released from procollagen in the ER rather than cis-Golgi/ER-Golgi intermediate compartment (ERGIC) is inconsistent with this hypothesis and raises the question as to how HSP47 release in the ER is regulated and whether this release is involved in the ER export mechanism. Our imaging of folded and misfolded procollagen trafficking from the ER, conducted in collaboration with Jennifer Lippincott-Schwartz, suggested novel, alternative hypotheses for the HSP47 release and quality control of procollagen folding in the ER, which are currently under investigation.

In another approach to understanding the cell biology of procollagen misfolding, we are investigating cell-stress response to procollagen with a Gly610 to Cys substitution in the triple helical region of the alpha2(I) chain in a mouse model of OI. The G610C mouse model mimics the Gly610 to Cys mutation found in a large group of patients from an Old Order Amish community in Pennsylvania. Our study of cultured fibroblasts and osteoblasts as well as tissues in this model revealed misfolding and accumulation of mutant molecules in the ER. Increased phosphorylation of the translation initiation factor EIF2 $\alpha$  indicated the presence of cell stress, although we found no evidence of conventional unfolded protein response (UPR) signaling. We

found that misfolded procollagen molecules are degraded by lysosomes via autophagy rather than by proteasomes via ER-associated degradation. Osteoblasts adapt to procollagen misfolding by enhancing autophagy and thereby reducing excessive accumulation of misfolded procollagen in the ER. Such an adaptation prevents cell death but is not sufficient to prevent abnormal cell function; e.g., we observed a blunted response to stimulation of collagen production by TGF- $\beta$  as well as abnormal Wnt signaling. Abnormal function of the latter pathways likely contributes to the abnormal osteoblast differentiation and maturation. The osteoblasts produce less and lower-quality bone matrix. Their abnormal differentiation into osteocytes appears to affect matrix mineralization as well. To compensate for reduced bone synthesis by each cell, G610C mice generate more osteoblasts. However, the combination of the resulting increase in bone formation surfaces with reduced bone formation rate at these surfaces disrupts normal bone modeling, causing, e.g., long-term entrapment of poorly organized woven bone between layers of lamellar bone. The disruption of the cortical bone matrix structure leads to more brittle bones, which have an increased susceptibility to fracture upon high energy impact despite normal cortical thickness and slightly higher cortical bone mineral density. (References 1, 2)

## Development of novel OI treatments

Based on these and other findings, we hypothesize that bone pathology associated with procollagen misfolding might be at least partially reversed by targeting the cell stress response to misfolded procollagen accumulation in the ER, thereby improving osteoblast function. However, this would not eliminate potentially detrimental effects of secreted mutant collagen in OI bone. Pharmacological treatment of osteoblast malfunction is a more realistic short-term approach to OI than suppression of dominant negative OI mutations by gene therapy or bone marrow transplantation. Moreover, the same approach is likely to be a better long-term strategy for treatment of osteoblast malfunction caused by procollagen misfolding in cases that do not involve pathogenic mutations.

In pursuing this strategy, we are currently targeting procollagen autophagy. Provided that misfolded procollagen accumulation in the ER is indeed involved in osteoblast malfunction, the simplest way to prevent such accumulation is to enhance the natural ability of the cell to remove and degrade the misfolded molecules via autophagy. Our preliminary study of a low protein diet (LPD) effect on G610C mice provided encouraging evidence of improved osteoblast function as well as bone matrix quality and mineralization. However, in addition to enhancing autophagy, LPD also causes cell stress associated with nutrient deprivation and alters animal growth. The latter and other confounding effects made the LPD study difficult to interpret (Reference 2). We are considering intermittent LPD as a potential component of the eventual treatment strategy, but it might still have a variety of unintended consequences. To unequivocally validate autophagy as a target before embarking on optimizing dietary and pharmacological treatments, we are currently pursuing an approach based on altering expression of *Atg5*, a key gene involved in regulation of autophagosome formation.

Our preliminary experiments confirmed that reduced autophagy causes increased OI severity. In heterozygous G610C animals, with reduced *Atg5* expression in all tissues, we observed close to 50% perinatal lethality compared with wild-type littermates, in contrast to negligible/undetectable perinatal lethality of heterozygous G610C mice with normal *Atg5* expression. Conditional *Atg5* knockout in mature osteoblasts resulted in dramatically increased bone malformations. We are currently investigating conditional *Atg5* knockout in osteoblast precursors, switching from low to normal/high *Atg5* expression and conditional targeted *Atg5* overexpression.

## Translational studies of patients with novel or unusual OI and EDS mutations

Abnormal collagen biosynthesis and malfunction of osteoblasts are also important factors in OI that is caused by other collagen mutations as well as by mutations in other proteins. Over the past several years, we assisted several clinical research groups in characterizing collagen biosynthesis and folding in fibroblasts from patients with newly discovered recessive forms of OI and closely related skeletal dysplasias caused by mutations in cartilage-associated protein (CRTAP), prolyl-3-hydroxylase (P3H1), cyclophilin B (CYPB), the collagen-binding molecular chaperone FKBP65, WNT1, the ER-membrane ion channel TRICB, Golgi-membrane metalloprotease S2P, and the transmembrane anterior posterior transformation protein 1 (TAPT1). In particular, our collaboration with Joan Marini suggested that the CRTAP/P3H1/CYPB complex functions as a procollagen chaperone. A deficiency in any of the three proteins delays procollagen folding, although their exact role in procollagen folding remains unclear. More surprisingly, we found no detectable changes in the procollagen folding rate in cultured fibroblasts from patients with FKBP65 mutations. Our data suggest that FKBP65 may affect post-translational modification of procollagen and deposition of collagen matrix by a different mechanism. It remains unclear why some FKBP65 mutations cause severe OI with joint contractures (Bruck syndrome) while others cause joint contractures without pronounced OI (Kuskokwim syndrome) or OI without pronounced joint contractures. Our study of TRICB-deficient cells revealed abnormal conformation and reduced thermal stability of type I procollagen, suggesting dysregulation of collagen chaperones in the ER or direct involvement of TRICB in procollagen folding (Reference 3). Our experiments indicated that pathogenic effects of mutations in the transmembrane protein TAPT1 and in site-2 metalloprotease (S2P) might not be directly related to disruptions in synthesis, folding, or trafficking of procollagen chains (Reference 4).

More recently, in collaboration with Carsten Bonnemann, we investigated collagen biosynthesis abnormalities caused by mutations in collagen prolyl-4-hydroxylase 1 (P4H1), which result in complex developmental abnormalities involving bones and other connective tissues. As expected, we found that patient skin fibroblasts secreted procollagen with significantly reduced thermal stability. However, we found no abnormalities in the procollagen folding or secretion rates and no evidence of misfolded procollagen accumulation in the cell. The latter findings are extremely surprising given that mutant P4H1 results in significantly reduced proline 4-hydroxylation, which is believed to be important for procollagen triple helix folding. We hypothesize that the folding rate is normalized through some compensatory action of procollagen chaperones. Consistently, our ongoing experiments point to abnormal composition of ER chaperones, but much remains to be done before we understand how patient fibroblasts manage to fold and secrete a normal amount of procollagen despite the P4H1 deficiency and how this deficiency causes connective tissue pathology.

## Extracellular matrix pathology in tumors and fibrosis

Another important advance from our work of the past several years was the characterization of a collagenase-resistant, homotrimeric isoform of type I collagen and its potential role in cancer, fibrosis, and other disorders. The normal isoform of type I collagen is a heterotrimer of two  $\alpha 1(I)$  chains and one  $\alpha 2(I)$  chain. Homotrimers of three  $\alpha 1(I)$  chains are produced in some fetal tissues, carcinomas, fibrotic tissues, as well as in rare forms of OI and EDS associated with  $\alpha 2(I)$  chain deficiency. We found the homotrimers to be at least 5–10 times more resistant to cleavage by all mammalian collagenases than the heterotrimers, and we determined the molecular mechanism of this resistance. Our studies suggested

that cancer cells might utilize the collagen isoform to build collagenase-resistant tracks, thus supporting invasion through stroma of lower resistance.

We also collaborated with the Stratakis lab to investigate bone tumors caused by defects in protein kinase A (PKA), a key enzyme in the cAMP signaling pathway. Initially, we investigated synthesis of type I collagen homotrimers. However, over the last three years, the focus of the study has shifted to abnormal differentiation of osteoblastic cells and deposition of bone within these tumors. We found that knockouts of various PKA subunits cause not only abnormal organization and mineralization of bone matrix but also novel bone structures that had not been previously reported. For instance, we observed free-standing cylindrical bone spicules with osteon-like organization of lamellae and osteocytes but an inverted mineralization pattern, a highly mineralized central core, and decreasing mineralization away from the central core. Currently, we are assisting the Stratakis lab in characterizing abnormal osteoblast maturation, the role of an abnormal inflammatory response, and effects of anti-inflammatory drug treatments in these animals (Reference 5). Improved understanding of bone tumors caused by PKA deficiencies may not only clarify the role of cAMP signaling but also suggest new approaches to therapeutic manipulation of bone formation in skeletal dysplasias.

## Multi-modal micro-spectroscopic imaging and mapping of tissues

Label-free micro-spectroscopic infrared and Raman imaging of tissues and cell cultures provides important information about the chemical composition, organization, and biological reactions inaccessible by traditional histology. However, applications of these techniques were severely restricted by light-path instabilities in thin hydrated specimens under physiological conditions. We resolved the problem by designing specimen chambers with precise thermo-mechanical stabilization for high-definition (HD) infrared imaging and Raman micro-spectroscopy, achieving spectral reproducibility up to two orders of magnitude better than with leading commercial instruments. The HD technology was essential for analysis of abnormal collagen matrix deposition by CRTAP- and FKBP65-deficient cells. It has enabled us to assist NIBIB scientists in characterizing a functionalized carbon-nanotube approach to the delivery of anticancer agents into cells that overexpress hyaluronate receptors and is crucial for our current studies of bone structure and mineralization in the mouse models of OI and PKA deficiencies described above.

The power of the technology is best illustrated by our studies of ECM structure and of composition effects on the function of cartilage in a mouse model of diastrophic dysplasia (DTD), an autosomal recessive dysplasia that affects cartilage and bone development and is caused by mutations in the SLC26A2 sulfate transporter, deficient sulfate uptake by chondrocytes, and resulting under-sulfation of glycosaminoglycans in cartilage matrix. In collaboration with Antonella Forlino and Antonio Rossi, we found that the deficiency results in under-sulfation of chondroitin and disorientation of collagen fibers, disrupting a thin protective layer at the articular surface and causing subsequent cartilage degradation. We investigated the relationship between chondroitin under-sulfation and the rate of its synthesis across the growing epiphyseal cartilage, and we built a mathematical model for the sulfation pathway, predicting treatment targets for sulfation-related chondrodysplasias and genes that might contribute to the juvenile idiopathic arthritis recently associated with single nucleotide polymorphisms in the gene encoding the SLC26A2 transporter.

We are extending the technology by combining imaging of bone and cartilage ECM composition and structure with biomechanical measurements at the same length scales. The mechanical properties of bone

and cartilage should depend on the deformation length scale because of the heterogeneous microscopic structure and the presence of different macroscopic regions and zones in these tissues. Nevertheless, biomechanical studies are rarely accompanied by mapping of tissue composition and structure. To address the problem, we are collaborating with Peter Bassler and Emiliós Dimitriadis on mapping cartilage elasticity by force microscopy at length scales appropriate for examining the material properties of the ECM and on combining it with our multimodal imaging technology.

While the ECM plays a key role in normal development and pathology of all tissues, most studies focus on expression of its components rather than its overall organization. Our multimodal imaging technology is helping to close this gap in *in vitro* studies of tissue sections and cell cultures. To translate these advances into clinical practice, we established a new collaboration with Bassler on using the technology to calibrate and test newer methods for noninvasive *in vivo* ECM studies by the solid-state magnetic resonance imaging (MRI) that is being developed in his laboratory.

In collaboration with Bassler and Roberto Romero, we are adapting HD infrared and Raman technologies for quantitative imaging of the structural organization and composition of ECM in the normal and pathological human placenta. Our initial measurements identified several previously unreported features of placental ECM: (1) highly anisotropic organization of fibrin and collagen, which may depend on and affect the blood flow and determine the tissue strength; (2) deposition of cholesteryl ester aggregates in fibrin fibrinoids from maternal blood; and (3) formation of collagen “fibroids” and high collagen content in matrix fibrinoids. From the perspective of practical clinical implications, one of the most promising applications of these spectroscopic approaches is that, by detecting neutrophil invasion, Raman microscopy can rapidly determine whether there is inflammation/infection in placental membranes after delivery. Given that it is essential to know whether the newborn child should be treated with antibiotics, we are currently evaluating whether the Raman technology would be sufficiently accurate and reliable for such testing.

## Publications

1. Mirigian LS, Makareeva E, Mertz EL, Omari S, Roberts-Pilgrim AM, Oestreich AK, Phillips CL, Leikin S. Osteoblast malfunction caused by cell stress response to procollagen misfolding in alpha2(I)-G610C mouse model of osteogenesis imperfecta. *J Bone Miner Res* 2016 31:1608-1616.
2. Mertz EL, Makareeva E, Mirigian LS, Koon KY, Perosky JE, Kozloff KM, Leikin S. Makings of a brittle bone: unexpected lessons from a low protein diet study of a mouse OI model. *Matrix Biol* 2016 52-54:29-42.
3. Cabral WA, Ishikawa M, Garten M, Makareeva EN, Sargent BM, Weis M, Barnes AM, Webb EA, Shaw NJ, Ala-Kokko L, Lacbawan FL, Hogler W, Leikin S, Blank PS, Zimmerberg J, Eyre DR, Yamada Y, Marini JC. Absence of the ER cation channel TMEM38B/TRIC-B disrupts intracellular calcium homeostasis and dysregulates collagen synthesis in recessive osteogenesis imperfecta. *PLoS Genet* 2016 12:e1006156.
4. Lindert U, Cabral WA, Ausavarat S, Tongkobpetch S, Ludin K, Barnes AM, Yeetong P, Weis M, Krabichler B, Srichomthong C, Makareeva EN, Janecke AR, Leikin S, Rothlisberger B, Rohrbach M, Kennerknecht I, Eyre DR, Suphapeetiporn K, Giunta C, Marini JC, Shotelersuk V. MBTPS2 mutations cause defective regulated intramembrane proteolysis in X-linked osteogenesis imperfecta. *Nat Commun* 2016 7:11920.
5. Saloustros E, Liu S, Mertz EL, Bhattacharyya N, Starost MF, Salpea P, Nesterova M, Collins M, Leikin S, Stratakis CA. Celecoxib treatment of fibrous dysplasia (FD) in a human FD cell line and FD-like lesions in mice with protein kinase A (PKA) defects. *Mol Cell Endocrinol* 2017 439:165-174.

## Collaborators

- Peter Basser, PhD, *Section on Quantitative Imaging and Tissue Sciences, NICHD, Bethesda, MD*
- Carsten Bonnemann, MD, *Neuromuscular and Neurogenetic Disorders of Childhood Section, NINDS, Bethesda, MD*
- Peter H. Byers, MD, *University of Washington, Seattle, WA*
- Paul J. Coucke, PhD, *Universitair Ziekenhuis Gent, Ghent, Belgium*
- Sarah Dallas, PhD, *University of Missouri, Kansas City, MO*
- Emilios K. Dimitriadis, PhD, *Biomedical Engineering & Physical Science Shared Resource Program, NIBIB, Bethesda, MD*
- Motomi Enomoto-Iwamoto, DDS, PhD, *University of Pennsylvania, Philadelphia, PA*
- Antonella Forlino, PhD, *Università degli Studi di Pavia, Pavia, Italy*
- Ken Kozloff, PhD, *University of Michigan, Ann Arbor, MI*
- Jennifer A. Lippincott-Schwartz, PhD, *Section on Organelle Biology, NICHD, Bethesda, MD*
- Joan Marini, MD, PhD, *Section on Heritable Disorders of Bone and Extracellular Matrix, NICHD, Bethesda, MD*
- George Patterson, PhD, *Section on Biophotonics, NIBIB, Bethesda, MD*
- Charlotte L. Phillips, PhD, *University of Missouri, Columbia, MO*
- Pamela G. Robey, PhD, *Craniofacial and Skeletal Diseases Branch, NIDCR, Bethesda, MD*
- Roberto Romero, MD, *Perinatal Research Branch, NICHD, Detroit, MI*
- Antonio Rossi, PhD, *Università degli Studi di Pavia, Pavia, Italy*
- Dan L. Sackett, PhD, *Section on Cell Biophysics, NICHD, Bethesda, MD*
- Constantine A. Stratakis, MD, D(med)Sci, *Section on Endocrinology and Genetics, NICHD, Bethesda, MD*

## Contact

For more information, email [leikins@mail.nih.gov](mailto:leikins@mail.nih.gov) or visit <http://physbiochem.nichd.nih.gov>.

## The Biological Impact and Function of Transposable Elements

Inherently mutagenic, the integration of retroviral and retrotransposon DNA is responsible for many pathologies, including malignancy. Given that some chromosomal regions are virtually gene free while others encode genes essential for cellular processes, the position of integration has great significance. Recent studies show clearly that integration occurs into specific types of sequences and that the targeting patterns vary depending on the specific retrovirus or retrotransposon. Currently, there is great interest in such patterns, in part because understanding the mechanisms that position HIV-1 insertions may lead to new antiviral therapies. In addition, retrovirus-based vectors are now being used for gene therapy. Early gene therapy vectors had patterns of integration that activated oncogenes and caused leukemia in patients. Therefore, to gauge the risks associated with new gene therapy vectors, it is essential that we characterize in detail the positions of integration and understand the mechanisms that position such integration. Our current work focuses on the integration of the long terminal repeat (LTR) retrotransposon Tf1 of *Schizosaccharomyces pombe*. This element allows us to study integration mechanisms using highly informative techniques of yeast genetics (Reference 1). As an example, we generated an expression technique that tags each integration with a highly specific serial number. With this method, we can sequence 500,000 independent integration events.

### Single nucleotide-specific targeting of the Tf1 retrotransposon promoted by the DNA-binding protein Sap1 of *S. pombe*

While the serial number system identified specific sequences that contributed to integration efficiency, sequence did not account for the selection of promoters. We had tested the transcription factors known to activate stress-response promoters and found that they do not contribute to the efficiency or position of Tf1 integration. However, a recent study of Switch-activating protein 1 (Sap1), an essential DNA-binding protein in *S. pombe*, showed that Sap1 binds to genomic positions where Tf1 integration occurs. To determine whether Sap1 plays a role in Tf1 retrotransposition, we studied *S. pombe* with the temperature-sensitive mutant *sap1-1* (Reference 2). At permissive temperature, Tf1 transposition is reduced ten-



**Henry L. Levin, PhD, Head,**  
*Section on Eukaryotic  
Transposable Elements*

Angela Atwood-Moore, BA, *Senior  
Research Assistant*

Anthony J. Hickey, PhD,  
*Postdoctoral Fellow*

Si Young Lee, PhD, *Postdoctoral  
Fellow*

Zelia Worman, PhD, *Postdoctoral  
Fellow*

Caroline Esnault, PhD, *Visiting  
Fellow*

Sudhir Rai, PhD, *Visiting Fellow*

Parmit Singh, PhD, *Visiting Fellow*

Oluwadamilola Bankole, BA,  
*Postbaccalaureate Fellow*

Michael Lee, BA,  
*Postbaccalaureate Fellow*



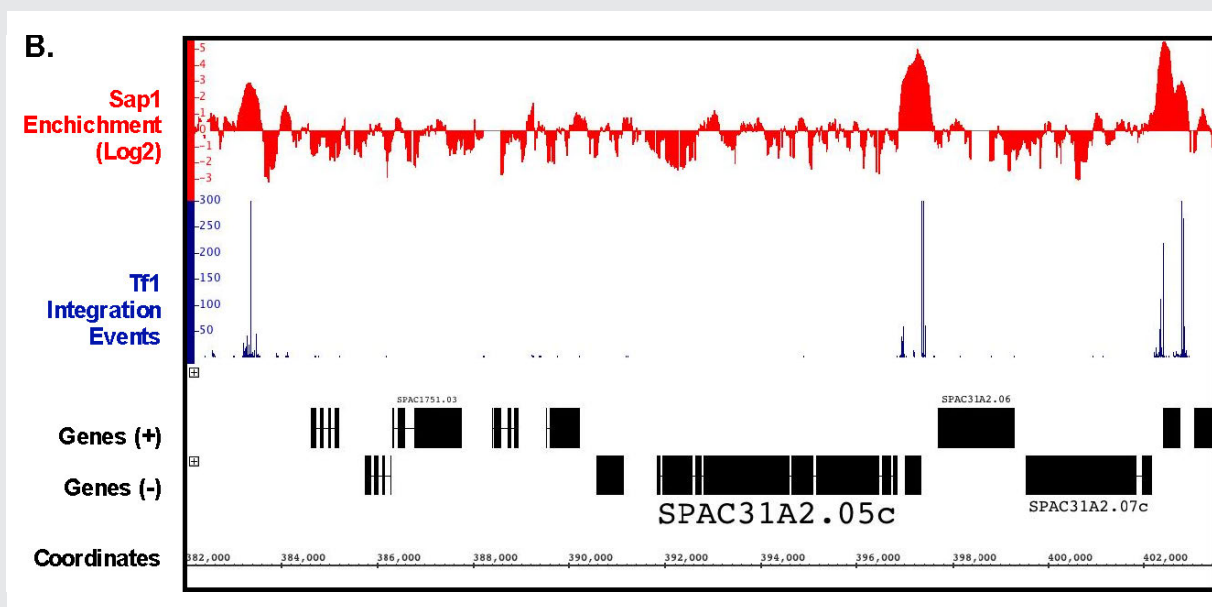

FIGURE 1. Serial Number integration data correlates with the position of Sap1 enrichment from ChIP-seq data.

A representative segment of chromosome 1 is shown.

fold compared with wild-type *sap1*<sup>+</sup>, and the defect was not the result of decreases in levels of Tf1 proteins or cDNA. The data argue that Sap1 contributes to the integration of Tf1. A mutation that results in 10-fold less integration might be expected to cause off-target integration. However, serial number sequencing of integration in cells with the *sap1-1* mutation showed position changes in just 10% of the integration events.

In another approach to determine whether Sap1 contributes to integration, we compared the integration data from the serial number system with previously published maps of Sap1 binding created with ChIP-seq. Analysis of the ChIP-seq data showed that 6.85% of the *S. pombe* genome was bound by Sap1. Importantly, we found that 73.4% of Tf1 insertions occurred within these Sap1-bound sequences (Reference 2). An example of this close association can be seen in a segment of chromosome 1 (Figure 1). Another important observation is that a strong correlation was observed between levels of integration in intragenic sequences and the amount of Sap1 bound. If Sap1 were directly responsible for positioning Tf1 integration, we would expect integration to take place at specific nucleotide positions relative to the nucleotides bound by Sap1. Using the ChIP-Seq data, we were able to identify a Sap1-binding motif, which closely resembled previously published motifs. We used the FIMO program of the MEME Suite to perform genomic searches, which identified 5,013 locations that matched this motif. The alignment of all these motifs revealed that 82% of all integration events cluster within 1 kb of this motif. Importantly, 43% of all integrations occurred within 50 bp of the motif and they had two dominant positions: 9 bp upstream and 19 bp downstream of the motif. The clustering of inserts at the Sap1 motif would be expected to occur if Sap1 covers its binding site on the DNA and directs integration to either side of the protein. Thus far, we have been unable to detect a direct interaction between Sap1 and Tf1 integrase (IN) with pull-down assays. However, our two-hybrid

assays detected a strong Sap1–IN interaction. The two-hybrid result together with the strong alignments of integration with Sap1 motif sequence and the reduction in integration in the *sap1-1* mutant argue that Sap1 plays an important role in Tf1 integration.

## A long terminal repeat retrotransposon of *Schizosaccharomyces japonicus* integrates upstream of RNA pol III–transcribed gene.

Transposable elements (TEs) are common constituents of centromeres. However, it is not known what causes this relationship. *Schizosaccharomyces japonicus* contains 10 families of Long Terminal Repeat (LTR) retrotransposons, elements that cluster in centromeres and telomeres. In the related yeast, *Schizosaccharomyces pombe*, the LTR retrotransposons Tf1 and Tf2 are distributed in the promoter regions of RNA pol II–transcribed genes. Sequence analysis of TEs indicates that the retrotransposon Tj1 of *S. japonicus* is related to Tf1 and Tf2 and uses the same mechanism of self-primed reverse transcription. Thus, we wondered why these related retrotransposons localized in different regions of the genome.

To characterize the integration behavior of Tj1, we expressed it in *S. pombe* (Reference 3). We found that Tj1 was active and capable of generating *de novo* integration in the chromosomes of *S. pombe*. The expression of Tj1 is similar to Type C retroviruses in that a stop codon at the end of the Gag retroviral gene must be present for efficient integration. Seventeen inserts were sequenced; thirteen occurred within 12 bp upstream of tRNA genes and three occurred at other RNA pol III–transcribed genes. The link between Tj1 integration and RNA pol III transcription is reminiscent of Ty3, an LTR-retrotransposon of *Saccharomyces cerevisiae*, which interacts with the transcription factor TFIIB and integrates upstream of tRNA genes. The integration of Tj1 upstream of tRNA genes and the centromeric clustering of tRNA genes in *S. japonicus* demonstrate that the clustering of this TE in centromere sequences is the result of a unique pattern of integration (Reference 3).

## Retrotransposon Tf1 induces genetic adaptation to environmental stress.

*Schizosaccharomyces pombe* possesses a compact genome that tightly restricts retrotransposon expression under normal growth conditions. However, when the retrotransposon Tf1 is expressed, it integrates into promoters of RNA Pol II–transcribed genes and, in many cases, this increases transcription of adjacent genes. The result, together with the Tf1 preference for stress-response promoters, led to the idea that Tf1 could be beneficial to its host by creating a pool of new alleles necessary for the host to survive changing environmental conditions. We tested the hypothesis by studying the Tf1 response to a stress such as exposure to cobalt and studying the fitness of cells with genomic insertions of Tf1 when exposed to cobalt.

Diverse cultures containing Tf1 integrated at 39,500 positions were grown competitively in cobalt. The proportion of cells with Tf1 at 141 positions greatly increased, suggesting that the integrations improved growth in cobalt. Analysis of the positions and reconstruction of strains with single insertions indicate that Tf1 integration improved growth in cobalt by inducing key regulators of the TOR pathway. The results provide strong evidence that retrotransposons have the potential to promote evolution, and they identify mechanisms that mitigate the toxicity of cobalt.

## Integration profiling: a whole–genome analysis of sequence function

The existing genome-wide methods for testing gene function consist largely of microarray hybridization

and deep sequencing of RNA, techniques that infer function from patterns of gene expression. Despite the valuable information produced by these methods, they do not provide a direct demonstration of gene function. To address this need, we developed integration profiling, a simple method capable of directly probing the function of the single-copy sequences throughout the genome of a haploid eukaryote. With transposons that readily disrupt ORFs (open reading frames) and sequencing technology that can position over 250 million insertions per reaction, the analysis of a single culture can identify which sequences in a eukaryotic genome are functional. In previous work, we found that the 'cut and paste' DNA transposon Hermes from the housefly is highly active in *S. pombe*. The high rate of integration and the disruption of ORFs mean that Hermes is suitable for mutagenesis studies. With integration profiling, large populations of cells with transposon insertions are grown for many generations, depleting the culture of cells that have insertions in genes important for division. In one experiment, we passaged cells for 74 generations until 13.4% of the cells in the final culture contained an integrated copy of Hermes. We determined the positions of the insertions in the culture by ligation-mediated PCR followed by Illumina sequencing. We identified 360,000 unique insertion events that produced an average of one insertion for every 29 bp of the *S. pombe* genome (Reference 4). A survey of known essential genes revealed very few insertions per ORF, whereas neighboring nonessential gene ORFs had high numbers of insertions.

A few years ago, a consortium systematically deleted the ORFs of *S. pombe* in heterozygous diploids and, after sporulation, designated which ORFs were essential (Kim et al., *Nat Biotechnol* 2010;28:617). Using these designations, we plotted the distribution of integration densities separately for the nonessential and essential ORFs. We also graphed the integration densities of a subclass of nonessential genes that, when deleted, resulted in small colonies. Clearly, the essential ORFs had significantly fewer insertions/kb than the nonessential ORFs, indicating that the integration profiles did indeed discriminate between essential and nonessential ORFs (Reference 4). Importantly, the nonessential ORFs required for full colony growth had intermediate densities of integration, indicating that intermediate levels of integration may be used to identify nonessential genes that nevertheless contribute to growth. The principal discrepancy between the designations made by the consortium and the Hermes integration is the group of 200 ORFs designated as nonessential, which exhibited very low levels of integration. Using PCR and DNA blotting, we found that the majority of these consortium designations were incorrect because the genes had not been successfully deleted. The results validate integration profiling as an accurate method for measuring gene function (Reference 4).

We extended the use of integration profiling to identify genes important for the formation of heterochromatin. Our initial strain contained a copy of *ura4* (gene encoding orotidine monophosphate decarboxylase) within the centromeric sequence. The heterochromatin present in the centromeric sequence silenced the expression of *ura4* and, as a result, allowed cells to grow in the presence of 5-fluoroorotic acid (FOA). We then induced Hermes transposition and passaged cultures for many generations. Disruption of genes required for heterochromatin allowed *ura4* to be expressed and, as a result, inhibited growth in a medium containing FOA. To identify the positions that tolerated disruption, we sequenced the integration sites of cells in the final culture. Our data set of one million integration positions contained, on average, one insertion for every 8 bp of the genome. We found that approximately 200 genes contained significantly fewer insertions than the remainder of the genome. Importantly, this gene set contained the majority of genes previously shown to contribute to heterochromatin formation. To test directly their contribution to heterochromatin and to characterize their mode of action, we are now analyzing candidates identified by

**FIGURE 2. Integration density in transcription units correlates with amounts of splicing.**

The numbers of HIV-1 integrations per kb in transcription units correlates with the amount of splicing (A and B). The preference for highly spliced transcription units depends on LEDGF (C and D). MEFs, mouse embryonic fibroblasts; MRC, Matched Random Control.

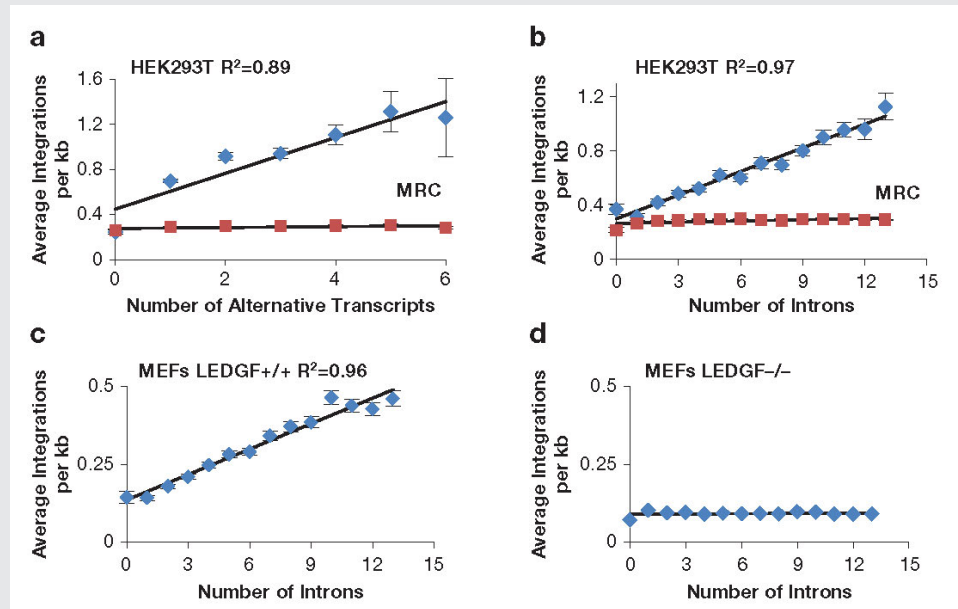

integration profiling that had not been previously studied.

## LEDGF/p75 interacts with mRNA splicing factors and targets HIV-1 integration to highly spliced gene.

The promise of immunotherapy of cancer and treatment of other diseases with gene therapy relies on retroviral vectors to stably integrate the corrective/therapeutic sequences in the genomes of the patient's cells. First-generation gene therapy used vectors derived from gamma retroviruses that were successful in correcting X-linked severe combined immunodeficiency (SCID-X1). However, the integration pattern had a bias for promoter sequences that resulted in the activation of proto-oncogenes and progression to T cell leukemia. Such adverse outcomes led to the use of lentivirus vectors for recent gene-therapy treatments. This switch to HIV-1-based vectors has occurred despite a fundamental lack of information about integration levels at specific genes, including proto-oncogenes. Structural and biochemical data show that HIV-1 integrase (IN) interacts with the host factor LEDGF/p75 (a chromatin-binding protein and transcription coactivator), and the interaction favors integration in the actively transcribed portions of genes (transcription units). However, little is known about how LEDGF/p75 recognizes transcribed sequences and whether cancer genes are favored.

To measure integration levels in individual transcription units and to identify the determinants of integration-site selection, we generated a high-density map of the integration sites of a single-round HIV-1 vector in HEK293T cells (Reference 5). Improvements in sequencing methods allowed us to map 961,274 independent integration sites; most of the sites occurred in just 2,000 transcription units. Importantly, the 1,000 transcription units with the highest numbers of integration sites were highly enriched for cancer-associated genes, which raised concerns about the safety of using lentivirus vectors in gene therapy. Analysis of the integration site densities in transcription units (integration sites per kb)

revealed a striking bias that favored transcription units that produced multiple spliced mRNAs and with transcription units that contain high numbers of introns (Figures 2A and 2B) (Reference 5). The correlations were independent of transcription levels, size of transcription units, and length of the introns. Analysis of previously published HIV-1 integration site data showed that integration density in transcription units in mouse embryonic fibroblasts also correlated strongly with intron number and that the correlation was absent from cells lacking LEDGF (Figures 2C and 2D). The data suggest that LEDGF/p75 not only tethers HIV-1 integrase to chromatin of active transcription units but also interacts with mRNA splicing factors. To test this, our collaborators Matthew Plumb and Mamuka Kvaratskhelia used tandem mass-spectrometry (MS-MS) to identify cellular proteins from nuclear extracts of HEK293T cells that interacted with GST-LEDGF/p75 (LEDGF/p75 tagged with glutathione S-transferase). The proteomic experiments found that LEDGF/p75 interacted with many components of the splicing machinery, including the small nuclear ribonucleic proteins (snRNP) SF3B1, SF3B2, and SF3B3 of U2 (a small nuclear RNA component of the spliceosome), U2-associated proteins PRPF8 and U2SURP, a factor of the U5 snRNP (SNRNP200), and many hnRNPs (heterologous ribonucleoproteins) that are associated with alternative splicing. The broad range of interactions with splicing factors suggested that LEDGF/p75 might contribute to splicing reactions. To test this, we performed RNAseq on HEK293T cells that were altered with TALEN endonucleases to truncate or delete the gene for LEDGF/p75, *PSIP1*. Analysis of transcription units that produced two or more spliced mRNA products showed that bi-allelic deletion of LEDGF/p75 significantly changed the ratio of spliced products in large numbers of transcription units (Reference 5). The results, together with our finding that integration in highly spliced transcription units was dependent on LEDGF, provide strong support for a model in which LEDGF/p75 interacts with splicing machinery and directs integration to highly spliced transcription units.

## Additional Funding

- NIH Intramural AIDS Targeted Antiviral Program (2015 and 2016)

## Publications

1. Sangesland M, Atwood-Moore A, Rai SK, Levin HL. Qualitative and quantitative assays of transposition and homologous recombination of the retrotransposon Tf1 in *Schizosaccharomyces pombe*. *Methods Mol Biol* 2016 1400:117-130.
2. Hickey A, Esnault C, Majumdar A, Chatterjee A, Iben J, McQueen P, Yang A, Mizuguchi T, Grewal S, Levin HL. Single nucleotide specific targeting of the Tf1 retrotransposon promoted by the DNA-binding protein Sap1 of *Schizosaccharomyces pombe*. *Genetics* 2015 201:905-924.
3. Guo Y, Singh P, Levin HL. A long terminal repeat retrotransposon of *Schizosaccharomyces japonicus* integrates upstream of RNA pol III transcribed genes. *Mob DNA* 2015 6:19.
4. Guo Y, Park JM, Cui B, Humes E, Gangadharan S, Hung S, Fitzgerald PC, Hoe KL, Grewal SI, Craig NL, Levin HL. Integration profiling of gene function with dense maps of transposon integration. *Genetics* 2013 195:599-609.
5. Singh PK, Plumb MR, Ferris AL, Iben JB, Wu X, Fadel HJ, Luke BT, Esnault C, Poeschla EM, Hughes SH, Kvaratskhelia M, Levin HL. LEDGF/p75 interacts with mRNA splicing factors and targets HIV-1 integration to highly spliced genes. *Genes Dev* 2015 29:2287-2297.

## Collaborators

- Nancy Craig, PhD, *The Johns Hopkins Medical School, Baltimore, MD*
- Shiv Grewel, PhD, *Laboratory of Biochemistry and Molecular Biology, NCI, Bethesda, MD*
- Stephen Hughes, PhD, *Retroviral Replication Laboratory, HIV Drug Resistance Program, NCI, Frederick, MD*
- Mamuka Kvaratskhelia, PhD, *Ohio State University, Columbus, OH*
- Philip McQueen, PhD, *Mathematical and Statistical Computing Laboratory, CIT, NIH, Bethesda, MD*
- Matthew Plumb, BS, *Ohio State University, Columbus, Ohio*
- Eric M. Poeschla, MD, *University of Colorado, Aurora, CO*

## Contact

For more information, email [henry\\_levin@nih.gov](mailto:henry_levin@nih.gov) or visit <http://sete.nichd.nih.gov>.

## Cell Cycle Regulation in Oogenesis

The long-term goal of our laboratory is to understand how the cell-cycle events of meiosis are coordinated with the developmental events of gametogenesis. Chromosome mis-segregation during female meiosis is the leading cause of miscarriages and birth defects in humans. Recent evidence suggests that many meiotic errors occur downstream of defects in oocyte growth and/or the hormonal signaling pathways that drive differentiation of the oocyte. Thus, an understanding of how meiotic progression and gamete differentiation are coordinated during oogenesis is essential to studies in both reproductive biology and medicine. We use the genetically tractable model organism *Drosophila melanogaster* to examine how meiotic progression is instructed by the developmental and metabolic program of the egg.

In mammals, studies on the early stages of oogenesis face serious technical challenges in that entry into the meiotic cycle, meiotic recombination, and the initiation of the highly conserved prophase I arrest all occur during embryogenesis. By contrast, in *Drosophila* these critical events of early oogenesis all take place continuously within the adult female. Easy access to the early stages of oogenesis, coupled with available genetic and molecular genetic tools, makes *Drosophila* an excellent model for studies on meiotic progression and oocyte development.

To understand the regulatory inputs that control early meiotic progression, we are working to determine how the oocyte initiates and then maintains the meiotic cycle within the challenging environment of the ovarian cyst. Our studies focus on the following questions, which are relevant to the development of all animal oocytes. What strategies does the oocyte use to protect itself against inappropriate DNA replication? How does the oocyte inhibit mitotic activity before meiotic maturation and the full growth and development of the egg? How does cell-cycle and metabolic status within the ovarian cyst influence the differentiation of the oocyte? To answer these questions, we have undertaken studies to determine the basic cell-cycle program of the developing ovarian cyst.



**Mary Lilly, PhD, Head, Section on Gamete Development**  
Lucia Bettedi, PhD, *Visiting Fellow*  
Weili Cai, PhD, *Visiting Fellow*  
Youheng Wei, PhD, *Visiting Fellow*  
Kuikwon Kim, MS, *Technician*  
Megan Bannon, BS, *Postbaccalaureate Fellow*  
Elena Ghanaim, BS, *Postbaccalaureate*  
Nicholas Johnson, BS, *Postbaccalaureate Fellow*

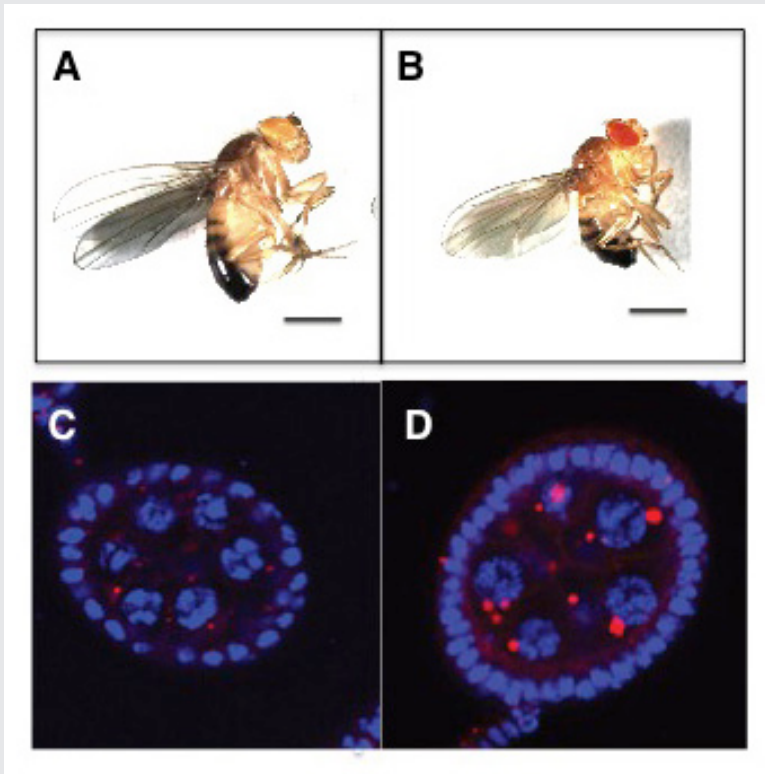

**FIGURE 1. The GATOR2 component Wdr24 regulates growth and autophagy.**

Representative images of (A) wild-type (WT) and (B) *wdr24*<sup>1</sup> mutant adult males. *wdr24*<sup>1</sup> males are notably smaller than WT males. Size bar is 100 μm. Representative images of (C) WT and (D) *wdr24*<sup>1</sup> egg chambers from well fed females stained with DAPI to mark DNA (blue) and LysoTracker (red) to mark autolysosomes. Note that *wdr24*<sup>1</sup> egg chambers accumulate large numbers of autolysosome-like structures under nutrient-replete conditions.

## The GATOR complex: integrating developmental and metabolic signals in oogenesis

We are interested in how metabolism influences oocyte growth, development, and quality. Target of Rapamycin Complex 1 (TORC1) is a primary regulator of cell growth and metabolism, which responds to several upstream signals, including nutrient availability, energy status, and growth factors. In the past year, we defined the role of the GATOR complex in the regulation of metabolic homeostasis, autophagic flux, endomembrane dynamics, and oocyte development. Our findings define *Drosophila* as an excellent model for the genetic dissection of the GATOR complex and its role in preventing the developmental defects and pathologies associated with deregulated TORC1 activity. Additionally, they clearly establish a conserved role for the GATOR complex in the regulation of meiotic progression and gametogenesis.

The GATOR complex comprises two sub-complexes. The GATOR1 complex inhibits TORC1 activity in response to amino acid starvation by preventing the targeting of TORC1 to lysosomes, where it is activated by the GTP-binding protein Rheb. GATOR1 is a trimeric protein complex, consisting of the proteins Nprl2, Nprl3, and Iml1. Recent evidence, from yeast and mammals, indicates that the components of the GATOR1 complex function as GTPase-activating proteins (GAP) that inhibit TORC1 activity by inactivating the Rag GTPases, which are required for TORC1 lysosomal recruitment. Notably, *Nprl2* and *Iml1* are tumor suppressor genes while mutations in *Iml1*, known as *DEPDC5* in mammals, are the leading cause of hereditary epilepsy.

The GATOR2 complex comprises five proteins: Seh1, Sec13, Mio, Wdr24, and Wdr59. Our work, as well as work from others, found that GATOR2 complex components activate TORC1 by opposing the TORC1-



inhibitory activity of GATOR1. Intriguingly, computational analysis indicates that Mio and Seh1, as well as several other members of the GATOR2 complex, have structural features consistent with coatamer proteins and membrane-tethering complexes. In line with the structural similarity to proteins that influence membrane curvature, we showed that three components of the GATOR2 complex, Mio, Seh1, and Sea2, localize to the outer surface of lysosomes, the site of TORC1 regulation. However, how GATOR2 inhibits GATOR1 activity, thus allowing for the robust activation of TORC1, remains unknown. Additionally, the role of the GATOR1 and GATOR2 complexes in both the development and physiology of multicellular animals remains poorly defined.

### THE GATOR1 COMPLEX REGULATES METABOLIC HOMEOSTASIS AND THE RESPONSE TO NUTRIENT STRESS IN *DROSOPHILA*.

We were interested in determining the role of the GATOR1 complex in the regulation of animal physiology. Towards this end, over the last year we characterized null mutants of the GATOR1 components *nprl2*, *nprl3*, and *iml1* in *Drosophila melanogaster*. We found that all three mutants had inappropriately high baseline levels of TORC1 activity and reduced adult viability. Consistent with increased TORC1 activity, GATOR1 mutants exhibited a cell-autonomous rise in cell growth. Surprisingly, escaper *nprl2* and *nprl3* mutant adults had a profound motility defect. In line with a non-autonomous role in the regulation of systemic metabolism, expressing the Nprl3 protein in the fat body, a nutrient storage organ, and hemocytes but not muscles and neurons rescued the motility of *nprl3* mutants. We also determined that *nprl2* and *nprl3* mutants fail to activate autophagy in response to amino acid limitation and are extremely sensitive to both amino acid and complete starvation. Thus, in *Drosophila*, in addition to maintaining baseline levels of TORC1 activity, the GATOR1 complex has retained a critical role in the response to nutrient stress. In summary, the TORC1 inhibitor GATOR1 contributes to multiple aspects of the development and physiology of *Drosophila*.

### The GATOR2 component Wdr24 regulates TORC1 activity and lysosome function.

While the GATOR1 complex has been implicated in a wide array of human pathologies, including cancer and hereditary forms of epilepsy, the *in vivo* relevance of the GATOR2 complex remains poorly understood in metazoans. We defined the *in vivo* role of the GATOR2 component Wdr24 in *Drosophila*. Using a combination of genetic, biochemical, and cell-biological techniques, we demonstrated that Wdr24 has both TORC1-dependent and -independent functions in the regulation of cellular metabolism. Through the characterization of a null allele, we found that Wdr24 is a critical effector of the GATOR2 complex; it promotes the robust activation of TORC1 and cellular growth in a broad array of *Drosophila* tissues (Figure 1). Additionally, epistasis analysis between *wdr24* and genes that encode components of the GATOR1 complex revealed that Wdr24 has a second critical function: the TORC1-independent regulation of lysosome dynamics and autophagic flux. Notably, we found that two additional members of the GATOR2 complex, Mio and Seh1, also play a TORC1-independent role in the regulation of lysosome function. These results represent a surprising and previously unrecognized function of GATOR2 complex components in the regulation of lysosomes. Consistent with our findings in *Drosophila*, through the characterization of a *wdr24*<sup>-/-</sup> knockout HeLa cell line, we determined that Wdr24 promotes lysosome acidification and autophagic flux in mammalian cells. Taken together, our data support the model wherein Wdr24 is a key effector of the GATOR2 complex, required for both TORC1 activation and the TORC1-independent regulation of lysosomes. Moreover, our data raise the interesting possibility that the GATOR2 complex regulates GATOR1 through the control of lysosome structure and/or function.

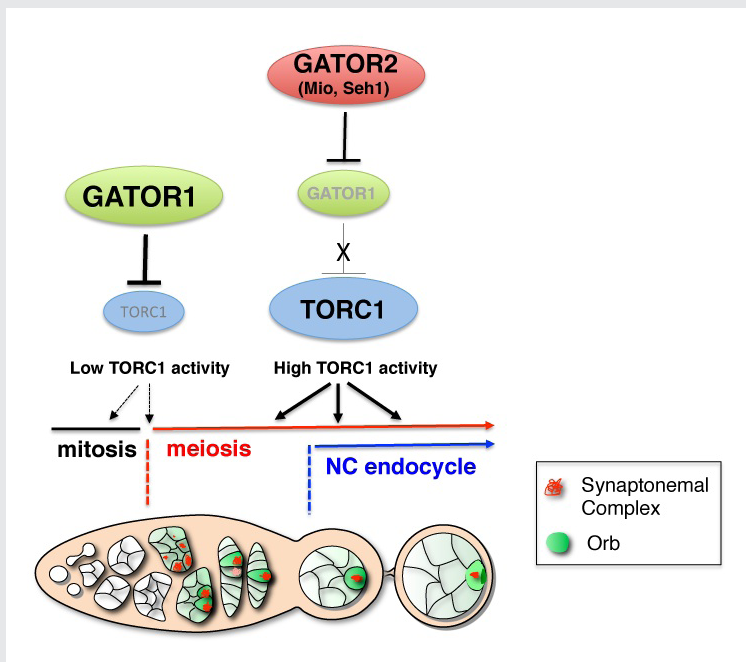

**FIGURE 2. A model for the role of the GATOR1 and GATOR2 complexes during *Drosophila* oogenesis**

The GATOR1 complex down-regulates TORC1 activity to promote the mitotic/meiotic transition after precisely four mitotic cyst divisions. Low TORC1 activity promotes the mitotic/meiotic transition. Whether the inhibition of TORC1 activity by the GATOR1 complex is required throughout the ovarian cyst divisions or precisely at the mitotic/meiotic juncture is currently undetermined and is thus presented as dashed arrows. After meiotic entry, the Mio and Seh1 components of the GATOR2 complex oppose the activity of the GATOR1 complex, thus preventing the constitutive inhibition of TORC1 during later stages of oogenesis. High TORC1 activity is required to drive the nurse cell endoreplication cycle as well as for the maintenance of the meiotic cycle into later stages of oogenesis.

## A conserved nutrient stress pathway regulates meiotic entry during oogenesis.

We defined a conserved pathway that controls the transition from the mitotic cycle to the meiotic cycle (Figure 2). In single-cell eukaryotes, the pathways that monitor nutrient availability are central to initiating the meiotic program and gametogenesis. A master regulator of metabolism in eukaryotes, TORC1 integrates information from several upstream signaling pathways. In *Saccharomyces cerevisiae*, an essential step in the transition to the meiotic cycle is the down-regulation of TORC1 by the GATOR1 complex in response to amino acid starvation. How metabolic inputs influence early meiotic progression and gametogenesis remains poorly understood in metazoans. We determined that, as is observed in yeast, the GATOR1 complex inhibits TORC1 activity to decelerate cellular metabolism and drive the mitotic/meiotic transition in developing ovarian cysts. In *im1* germline depletions, ovarian cysts undergo an extra mitotic division prior to meiotic entry. The TORC1 inhibitor Rapamycin can suppress this extra mitotic division. Thus, high TORC1 activity delays the mitotic/meiotic transition. Conversely, mutations in *Tor*, which encodes the catalytic subunit of the TORC1 complex, result in premature meiotic entry. Thus, the levels of TORC1 activity control the timing of the mitotic/meiotic decision in a metazoan. Taken together, our data indicate that the role of the GATOR1 complex in the regulation of meiotic entry has been conserved from single-cell to multicellular animals. The data strongly suggest that catabolic metabolism, triggered by low TORC1 activity, is a conserved feature of early meiosis in many eukaryotes.

## The GATOR1 complex promotes genomic stability during the early meiotic cycle.

Meiosis must accomplish two seemingly incompatible goals. First, it must faithfully copy and distribute genetic material to the next generation. Second, it must promote genomic diversity through meiotic

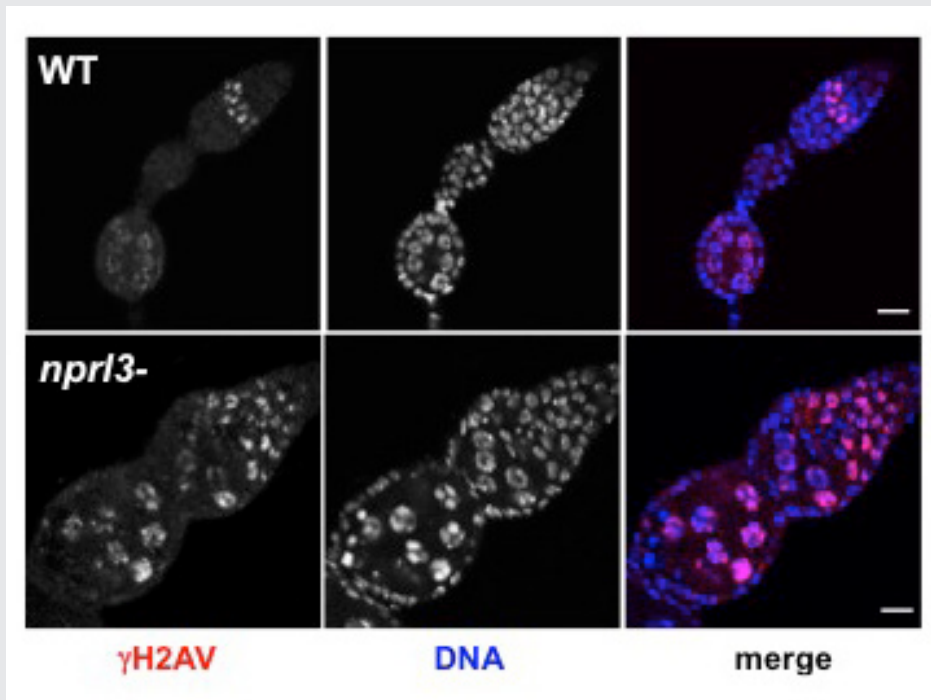

**FIGURE 3.** *nprl3*-mutant ovarian cysts have elevated levels of DNA damage.

Note that WT ovarian cysts rapidly repair meiotic DSB, as indicated by the loss of gamma-H2Av in the early germarium. In contrast, *nprl3* mutants retain high levels of gamma-H2Av into late stages of oogenesis.

recombination, a process initiated by the production of DNA double-stranded breaks (DSBs). In *Drosophila* females, entry into meiosis requires the down-regulation of TORC1 by the GATOR1 complex. However, why a nutrient sensor has retained an essential role in the regulation of the early meiotic cycle in a metazoan remains unclear. We reasoned that, in addition to promoting meiotic entry, the GATOR1 complex might facilitate other events of the early meiotic cycle such as the highly conserved events of meiotic recombination. The controlled generation of DSBs initiates meiotic recombination in early prophase of meiosis I. Over the last year, we found that the GATOR1 complex promotes genomic stability in the presence of meiotic DSBs. *nprl2*- and *nprl3*-mutant oocytes exhibit a dramatic increase in the steady state number of DSBs (Figure 3). Moreover, in contrast to wild-type oocytes that repair their DSBs prior to oocyte growth, *nprl2*- and *nprl3*-mutant oocytes retain DSBs into late states of oogenesis. In *nprl2*- and *nprl3*-mutant ovarian cysts, the rise in unrepaired DSBs is accompanied by an increase in p53 activity, as monitored by a p53 reporter construct. p53 is a highly conserved transcription factor that mediates a response to genotoxic stress. Strikingly, inhibiting the generation of meiotic DSBs strongly suppressed p53 activity in the *nprl3*<sup>1</sup>-mutant background. From these data, we conclude that the GATOR1 complex is required to maintain genomic stability in the presence of meiotic DSBs and is thus essential for oocytes to safely complete meiotic recombination. We also determined that *nprl2* and *nprl3* mutants exhibit profound encapsulation defects, with multiple ovarian cysts enclosed within single layer of follicle cells. Intriguingly, a similar encapsulation defect is observed in mutants of the Inducer of MEiosis 4 (*ime4*) gene in *Drosophila*. In budding yeast, IME4 is an essential regulator of early meiotic progression and gametogenesis. These data provide further support for the model that the GATOR1 complex has retained a critical role in the early meiotic cycle and early gametogenesis in metazoans.

## Additional Funding

- NICHD Director's Challenge Award

## Publications

1. Wei Y, Reveal B, Cai W, Lilly MA. The GATOR1 complex regulates metabolic homeostasis and the response to nutrient stress in *Drosophila*. *G3* 2016; Epub ahead of print.
2. Cai W, Wei Y, Jarnik M, Reich J, Lilly MA. The GATOR2 component Wdr24 regulates TORC1 activity and lysosome function. *PLoS Genetics* 2016 12(5):e1006036.
3. Wei Y, Reveal B, Reich J, Laursen W, Senger S, Akar T, Iida-Jones I, Cai W, Jarnik M, Lilly MA. TORC1 regulators Iml1/GATOR1 and GATOR2 control meiotic entry and oocyte development in *Drosophila*. *Proc Natl Acad Sci USA* 2014 111:E5670-E5677.
4. Wei Y, Lilly MA. The TORC1 inhibitors Npr12 and Npr13 mediate an adaptive response to amino-acid starvation in *Drosophila*. *Cell Death Differ* 2014 21:1460-1468.

## Collaborators

- Juan Bonifacino, PhD, *Section on Intracellular Protein Trafficking, NICHD, Bethesda, MD*
- Brian Calvi, PhD, *Indiana University, Bloomington, IN*
- Chi-Hon Lee, MD, PhD, *Section on Neuronal Connectivity, NICHD, Bethesda, MD*

## Contact

For more information, email [mlilly@helix.nih.gov](mailto:mlilly@helix.nih.gov) or visit <https://science.nichd.nih.gov/confluence/display/lilly>.

## Interplay between Membrane Organelles, Cytoskeleton, and Metabolism in Cell Organization and Function

We investigate the global principles underlying cell behavior at both small and large spatial scales. At the small scale, we employ the super-resolution imaging techniques of photoactivated localization microscopy (PALM), interferometric 3D PALM, single-particle tracking PALM, and pair-correlation PALM to map the spatial organization, stoichiometry, and dynamics of proteins associated with various membrane-bound compartments and with the cytoskeleton. We also employ fluorescence photobleaching, photoactivation, fluorescence correlation, and fluorescence energy transfer methods to measure protein-protein interactions, protein turnover rates, and protein association rates. Such approaches allow us to assay cellular functions, including receptor stoichiometry and protein clustering and diffusion behavior at the nanometric scale in living cells. At the large scale, we investigate how complex behaviors of cells arise, such as cell crawling, polarization, cytokinesis, and viral budding. We study these complex behaviors by quantitatively analyzing diverse intracellular processes, including membrane trafficking, autophagy, actin/microtubule dynamics, and organelle assembly/disassembly pathways, which undergo dramatic changes as cells alter their behavior and organization throughout life. To assist these efforts, we combine various fluorescence-based imaging approaches, including total internal reflection fluorescence (TIRF) microscopy imaging and spinning-disk and laser-scanning confocal microscopy, with FRAP (fluorescence recovery after photobleaching), FLIP (fluorescence loss in photobleaching), and photoactivation to obtain large image data sets. We process the data sets computationally to extract biochemical and biophysical parameters, which can be related to the results of conventional biochemical assays. We then use the results to generate mechanistic understanding and predictive models of the behavior of cells and subcellular structures (including endoplasmic reticulum, Golgi, cilia, endosomes, lysosomes, autophagosomes, and mitochondria) under healthy and pathological conditions.

### ER structure and dynamics visualized with increased spatio-temporal resolution

The endoplasmic reticulum (ER) consists of interconnected tubules and flattened sheets that extend from the nuclear envelope to the periphery of the cell, impacting every cellular compartment through



**Jennifer Lippincott-Schwartz, PhD, Head, Section on Organelle Biology**

Sarah Cohen, PhD, *Visiting Fellow*

Carolyn Ott, PhD, *Staff Scientist*

Christopher Obara, PhD, *Postdoctoral Fellow*

Timothy Petri, PhD, *Postdoctoral Fellow*

Prabuddha Sengupta, PhD, *Postdoctoral Fellow*

Arnold Seo, PhD, *Postdoctoral Fellow*

Alex Valm, PhD, *Postdoctoral Fellow*

Aubrey Weigel, PhD, *Postdoctoral Fellow*

Lingfeng Chen, PhD, *Volunteer*

Prasanna Satpute, PhD, *Volunteer*

Alex Ritter, BA, *Graduate Student*

Bennett Waxse, BA, *Graduate Student*

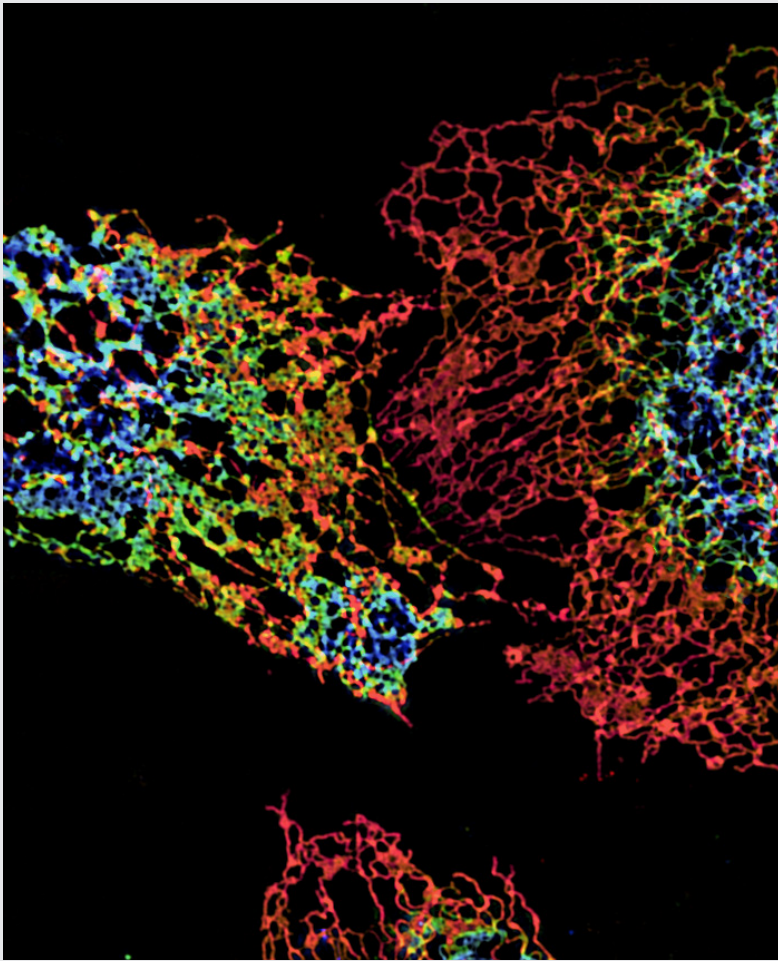

#### ER STRUCTURE VISUALIZED USING STRUCTURED ILLUMINATION MICROSCOPY (SIM)

Structure of peripheral ER in three cells labeled with an ER protein marker visualized by three-dimensional SIM. The color coding represents different z heights of the ER.

its contacts and functional interactions. Mutations in proteins that regulate the shape of the ER lead to various neurological disorders. We employed five different super-resolution technologies with complementary strengths and weaknesses in spatial and temporal capabilities to study the fine morphology and dynamics of the peripheral ER. A high-speed variation of structured illumination microscopy (SIM) allowed ER dynamics to be visualized at unprecedented speeds and resolution. Three-dimensional SIM (3D-SIM) and Airyscan imaging allowed comparison of the fine distributions of different ER-shaping proteins. Lattice light sheet point accumulation for imaging in nanoscale topography (LLS-PAINT) and focused ion-beam scanning electron microscopy (FIB-SEM) permitted 3D characterization of various ER structures. Using these approaches, we observed that many ER structures previously proposed to be flat membrane sheets are instead densely packed tubular arrays, which we call ER matrices. The matrices were extremely compact, with spaces

between tubules below the resolving power of most super-resolution methodologies. We also discovered that ER tubules and junctions undergo rapid oscillations, rapidly interconverting from tight to loose arrays. The oscillations of tubules and junctions were energy dependent and allowed the ER to interconvert between tight and loose tubule networks. Our finding of dense tubular matrices in areas previously thought of as flat sheets provides a new model for maintaining and generating ER structure. In this model, ER matrices would sequester excess membrane proteins and lipids, and their dynamic interconversion into loose tubule arrays would permit the ER to rapidly extend its shape to reach the cell periphery, for example during cell locomotion.

### ER trapping reveals that Golgi enzymes continually revisit the ER through a recycling pathway that controls Golgi organization.

The Golgi apparatus is the major processing and sorting station at the crossroads of the secretory pathway,

containing specialized sorting and transport machinery, which either drive secretory trafficking or filter out selected membrane and protein components for return to the ER for continued use. How the Golgi maintains its structure and function amidst this ongoing bi-directional membrane trafficking has been the subject of a long-standing debate. In particular, it is unclear whether Golgi enzymes remain localized within the Golgi or constitutively cycle through the ER.

To address this question, we used a rapamycin trapping assay to test whether Golgi enzymes become trapped in the ER upon expression of both an ER-trapping protein and Golgi enzyme bait. We found that within four hours of rapamycin treatment, li-FKBP12 (i.e., ER trapper) trapped nearly all Golgi-localized FRB-Golgi enzyme (i.e., Golgi bait) in the ER. Direct redistribution from the Golgi to the ER during rapamycin treatment occurred because selective photoactivation of FRB-tagged, photoactivatable Golgi enzyme in the Golgi resulted in the signal shifting to the ER. In the ER, fluorescent forms of FRB-Golgi enzyme and li-FKBP12 underwent FRET, indicating direct binding upon rapamycin-induced redistribution. By contrast, use of li-FRB, which we showed is an inefficient ER trap, resulted in minimal redistribution of FKBP12-tagged Golgi enzymes during rapamycin treatment. These data demonstrated that Golgi enzymes constitutively cycle through the ER. Using our trapping scheme, we further identified roles of Rab6a and iPLA<sub>2</sub> in Golgi enzyme recycling and showed that retrograde transport of Golgi membrane is necessary for Golgi dispersal during microtubule depolymerization and mitosis.

## Publications

1. Sengupta P, Satpute-Krishnan P, Seo AY, Burnette DT, Patterson GH and Lippincott-Schwartz J. ER trapping reveals Golgi enzymes continually revisit the ER through a recycling pathway that controls Golgi organization. *Proc Natl Acad Sci USA* 2015 112:6752-6761.
2. Yao PJ, Petralia RS, Ott C, Wang YX, Lippincott-Schwartz J, Mattson MP. Dendrosomatic Sonic Hedgehog signaling in hippocampal neurons regulates axon elongation. *J Neurosci* 2015 35:16126-16141.
3. Rikhy R, Mavrikakis M, Lippincott-Schwartz J. Dynamin regulates metaphase furrow formation and plasma membrane compartmentalization in the syncytial *Drosophila* embryo. *Biol Open* 2015 4:301-311.
4. Nixon-Abell J, Obara CJ, Weigel AV, Li D, Legant WR, Xu CS, Pasolli HA, Harvey K, Hess HF, Betzig E, Blackstone C, Lippincott-Schwartz J. Increased spatiotemporal resolution reveals highly dynamic dense tubular matrices in the peripheral ER. *Science* 2016 354(6311):Epub ahead of print.
5. Sulkowski MJ, Han TH, Ott C, Wang Q, Verheyen EM, Lippincott-Schwartz J, Serpe M. A novel, noncanonical BMP pathway modulates synapse maturation at the *Drosophila* neuromuscular junction. *PLoS Genet* 2016 12(1):e1005810.

## Collaborators

- Eric Betzig, PhD, *Howard Hughes Medical Institute, Janelia Farm Research Campus, Ashburn, VA*
- Craig Blackstone, MD, PhD, *Cell Biology Section, NINDS, Bethesda, MD*
- Yu-Tsung Chen, PhD, *Section on Cell Cycle Regulation, NICHD, Bethesda, MD*
- Harald Hess, PhD, *Howard Hughes Medical Institute, Janelia Farm Research Campus, Ashburn, VA*
- Mark P. Matteson, PhD, *Laboratory of Neurosciences, NIA, Baltimore, MD*
- Jonathon J. Nixon-Abell, PhD, *Cell Biology Section, NINDS, Bethesda, MD*
- George Patterson, PhD, *Section on Biophotonics, NIBIB, Bethesda, MD*

- Richa Rikhy, PhD, *Indian Institute of Science Education and Research (IISER), Pune, India*
- Mihaela Serpe, PhD, *Unit on Cellular Communication, NICHD, Bethesda, MD*
- Pamela J. Yao, PhD, *Cellular and Molecular Neurosciences Section, NIA, Baltimore, MD*

## Contact

For more information, email [lippincj@mail.nih.gov](mailto:lippincj@mail.nih.gov) or visit <http://lippincottschwartzlab.nichd.nih.gov>.



## Neurosecretory Proteins in Neuroprotection, Neurodevelopment, and Cancer

We study the cell biology of neuroendocrine cells and the function of neuropeptides and the neurotrophic factor carboxypeptidase E (CPE)/Neurotrophic Factor- $\alpha$ 1 (NF- $\alpha$ 1) in health and disease. Our focus is three-fold, to: (1) investigate the mechanisms of biogenesis and intracellular trafficking of dense-core secretory granules containing neuropeptides and their processing enzymes; (2) investigate the role of serpinin, a novel chromogranin A-derived peptide discovered in our lab, in neural and cardiac function; and (3) determine the non-enzymatic neurotrophic role of CPE/NF- $\alpha$ 1 in neuronal function and cancer. Our work led to the discovery of novel molecular mechanisms of protein trafficking to the regulated secretory pathway (RSP) and identified players and mechanisms that control secretory granule biogenesis and transport in neuroendocrine cells. Recently, we found a new role for CPE/NF- $\alpha$ 1 as a trophic factor that mediates neuroprotection, neurodevelopment, and anti-depression. We also identified a splice variant of CPE/NF- $\alpha$ 1 (CPE-DN) that drives metastasis in various cancer types. Using cell lines, primary cell cultures, mouse models, and human tumor specimens and sera, our studies have deepened the understanding of neurodegenerative diseases, memory, learning, depression, cardiac function, obesity, and metastasis in cancer.

### Mechanism of sorting, transport, and regulated secretion of neuroproteins

The intracellular sorting of pro-neuropeptides and neurotrophins to the RSP is essential for processing, storage, and release of active proteins and peptides in the neuroendocrine cell. We investigated the sorting of pro-opiomelanocortin (POMC, pro-ACTH/endorphin), proinsulin, and brain-derived neurotrophic factor (BDNF) to the RSP. Our studies showed that these pro-proteins undergo homotypic oligomerization as they traverse the cell from the site of synthesis in the endoplasmic reticulum (ER) to the trans-Golgi network (TGN). In the TGN, the pro-proteins are sorted into dense-core granules of the RSP for processing by prohormone convertases and CPE and then secreted. We showed that the sorting of prohormones to the RSP occurs by a receptor-mediated mechanism. Site-direct mutagenesis studies identified a 3-D consensus sorting motif consisting of two acidic residues found in POMC, proinsulin, and BDNF. We identified



**Y. Peng Loh, PhD**, *Head, Section on Cellular Neurobiology*

Niamh X. Cawley, PhD, *Staff Scientist*

Hong Lou, MD, *Senior Research Assistant*

Xuyu Yang, PhD, *Research Fellow*

Yong Cheng, PhD, *Postdoctoral Fellow*

Prabhuanand Selvaraj, PhD, *Postdoctoral Fellow*

Leila Toulabi, PhD, *Postdoctoral Fellow*

Lin Cong, MD, *Special Volunteer*

Vida Falahatian, MD, *Special Volunteer*

Zhaojin Li, MS, *Special Volunteer*

Alicja Woronowicz, MD, PhD, *Special Volunteer*

Wei Yao, PhD, *Special Volunteer*

the transmembrane form of CPE as an RSP sorting receptor that is specific for the sorting signal of these proproteins.

We also investigated the role of secretogranin III (SgIII) as a surrogate sorting receptor for membrane CPE in targeting POMC to the RSP. Using RNA interference (siRNA) to knock down SgIII or CPE expression in pituitary AtT20 cells, we demonstrated in both cases that POMC secretion via the constitutive secretory pathway was elevated. In double CPE-SgIII knock-down cells, elevated constitutive secretion of POMC and stimulated secretion of ACTH were perturbed. Thus, CPE mediates trafficking of POMC to the RSP, and SgIII may play a compensatory role for CPE in POMC sorting to the RSP.

Transport of vesicles containing hormone or BDNF to the plasma membrane for activity-dependent secretion is critical for endocrine function and synaptic plasticity. We showed that the cytoplasmic tail of a transmembrane form of CPE in hormone- or BDNF-containing dense-core secretory vesicles plays an important role in their transport to the vesicles' release site. In hippocampal neurons and pituitary cells, overexpression of the CPE tail inhibited the movement of BDNF- and POMC/CPE-containing vesicles to the processes, respectively. The transmembrane CPE tails on the POMC/ACTH and BDNF vesicles anchors these organelles, which interact with the microtubule-based motors dynactin and KIF1A/KIF3A to effect anterograde vesicle movement to the plasma membrane for activity-dependent secretion in endocrine cells and neurons.

## Serpinin, a chromogranin A-derived peptide, regulates secretory granule biogenesis, cell survival, cardiac function, and angiogenesis.

Our previous studies in pituitary AtT-20 cells provided evidence that an autocrine mechanism up-regulates large dense-core vesicle (LDCV) biogenesis to replenish LDCVs following stimulated exocytosis of the vesicles. We identified the autocrine signal as serpinin, a novel 26 amino-acid, chromogranin A (CgA)-derived peptide cleaved from the C-terminus of CgA. Serpinin is released in an activity-dependent manner from LDCVs and activates adenylyl cyclase to raise cAMP levels and protein kinase A in the cell. This leads to translocation of the transcription factor Sp1 from the cytoplasm into the nucleus and enhanced transcription of a protease inhibitor, protease nexin 1 (PN-1), which then inhibits granule protein degradation in the Golgi complex, stabilizing and raising granule protein levels in the Golgi and enhancing LDCV formation. We also identified modified forms of serpinin, pyroglutamyl-serpinin (pGlu-serpinin) and a C-terminally extended form, serpinin-RRG, in the secretion medium of AtT20 cells and in rat heart tissue. pGlu-serpinin is synthesized and stored in secretory granules and secreted in an activity-dependent manner from AtT20 cells. We observed pGlu-serpinin immunostaining in nerve terminals of neurites in mouse brain, olfactory bulb, and retina, suggesting a role as a neurotransmitter or neuromodulator. Additionally, pGlu-serpinin exhibited neuroprotective activity against oxidative stress in AtT20 cells and against low  $K^+$ -induced apoptosis in rat cortical neurons. In collaboration with Bruno Tota, we found that pGlu-serpinin has positive inotropic activity in cardiac function, with no change in blood pressure and heart rate. pGlu-serpinin acts through a  $\beta$ 1-adrenergic receptor/adenylyl cyclase/cAMP/PKA pathway in the heart. pGlu-serpinin and other CgA-derived cardio-active peptides emerge as novel  $\beta$ -adrenergic inotropic and lusitropic modulators. Together, they can play a key role in the myocardium's orchestration of its complex response to sympatho-chromaffin stimulation. Additionally, we recently found that pGlu serpinin is a powerful cardioprotectant after ischemia.

## Role of CPE/NF- $\alpha$ 1 in neuroprotection and anti-depression during stress

We generated a CPE/NF- $\alpha$ 1 knock-out (KO) mouse to study the function of CPE *in vivo*. This KO mouse exhibited obesity, infertility, and diabetes as well as learning and memory deficits and depressive-like behavior (Reference 1). Interestingly, a null mutation in the gene encoding CPE/NF- $\alpha$ 1 was recently identified in a female who has clinical features such as obesity, type 2 diabetes, learning disabilities, and hypogonadotropic hypogonadism, similar to the *Cpe*-KO mouse, indicating the importance of CPE. Using the *Cpe*-KO mice as a model to study the nervous system deficiencies and Morris water maze and object-preference tests, we showed defects in learning and memory and, in the forced swim test, depressive-like behavior. Analysis of the brain of 6- to 14-week-old *Cpe*-KO mice revealed poor dendritic pruning in cortical and hippocampal neurons, which could affect synaptogenesis. Electrophysiological measurements showed a defect in the generation of long-term potentiation in hippocampal slices. A major cause of the defects is the loss of neurons in the CA3 region of the hippocampus. Hippocampal neurons in CA3 region are enriched in CPE and were normal at three weeks of age just before weaning, indicating that the defect was not developmental. The degeneration is likely caused by epileptic-like neuronal firing, releasing large amounts of glutamate during weaning stress. Hence CPE/NF- $\alpha$ 1 is important for the survival of the CA3 neurons. We then showed that CPE/NF- $\alpha$ 1, either overexpressed or applied externally to cultured hippocampal or cortical neurons, protected these neurons from apoptosis induced by oxidative stress with hydrogen peroxide. Moreover, a non-enzymatically active form of CPE/NF- $\alpha$ 1 had the same effect, indicating that its action is independent of enzymatic activity. We propose that CPE/NF- $\alpha$ 1 acts extracellularly as a signaling molecule by binding to a receptor to mediate neuroprotection. To this end, we demonstrated that  $^{125}\text{I}$  CPE/NF- $\alpha$ 1 bound to HT22 cells, an immortalized hippocampal neuronal cell line, in a saturable manner, and that the binding was specifically displaced by non-iodinated CPE/NF- $\alpha$ 1 but not by bovine serum albumin, suggesting the existence of a receptor.

The mechanism of action of CPE/NF- $\alpha$ 1 in neuroprotection involves the activation of the ERK1/2 and the Akt signaling pathways, which then leads to enhanced transcription/translation of a pro-survival mitochondrial protein, Bcl2, inhibition of caspase 3 activation, and promotion of neuronal survival (Reference 2). Furthermore, this CPE/NF- $\alpha$ 1-mediated neuroprotection pathway is activated by rosiglitazone, a PPAR $\gamma$  ligand, which binds to PPAR $\gamma$  binding sites in the CPE promoter. Examination of this pathway during stress *in vivo* revealed that, after mild chronic restraint stress (CRS) for 1h/day for seven days, mice showed significantly elevated levels of CPE/NF- $\alpha$ 1 mRNA and protein, as well as of the anti-apoptosis protein Bcl2, in the hippocampus. *In situ* hybridization studies indicated especially elevated CPE/NF- $\alpha$ 1 mRNA levels in the CA3 region and no gross neuronal cell death after mild CRS. Furthermore, primary hippocampal neurons in culture showed elevated CPE/NF- $\alpha$ 1 and Bcl2 expression and a decline in Bax, a pro-apoptotic protein, after treatment with the synthetic glucocorticoid dexamethasone. This up-regulation was mediated by glucocorticoid binding to glucocorticoid-regulatory element (GRE) sites on the promoter of the *Cpe* gene. Thus, during mild CRS, when glucocorticoid is released, CPE/NF- $\alpha$ 1 and Bcl2 expression are coordinately up-regulated to mediate neuroprotection of hippocampal neurons. The importance of CPE as a neuroprotective agent was demonstrated by the absence of an increase in Bcl2 in the hippocampus of *Cpe*-KO mice, leading to the degeneration of the CA3 neurons.

The relevance of CPE/NF- $\alpha$ 1 in neuroprotection in humans was indicated by our studies on a mutation of the *CPE* gene found in an Alzheimer patient (Reference 3). Our search in GeneBank EST database identified a sequence entry from cortex of an Alzheimer's disease (AD) patient that had three adenosine inserts in

the *CPE* gene, thereby introducing nine amino acids, including two glutamines, into the mutant protein, herein called CPE-QQ. Expression of CPE-QQ in Neuro2a cells indicates that it is not secreted. Co-expression of wild-type (WT) and CPE-QQ in Neuro2a cells resulted in degradation of both forms of the protein and reduction in secretion of WT CPE. Immunocytochemical studies show that CPE-QQ stains in the perinuclear region of the cells and co-stained with Calnexin, an ER marker, consistent with localization of the mutant in the ER. Moreover, many cells appear rounded, indicating unhealthy cells that might be undergoing ER stress, unlike the cells expressing WT, which show staining in the cell body and neurites. Overexpression of CPE-QQ in rat primary hippocampal neurons resulted in increased levels of the ER stress marker CHOP, decreased levels of pro-survival protein Bcl-2, and increased neuronal cell death. This indicates that CPE-QQ induces cell death through ER stress and down-regulation of Bcl-2 expression. We then generated transgenic mice overexpressing CPE-QQ and showed that, at 50 weeks but not at 11 weeks, the animals exhibited memory deficits compared with WT mice, but that their spatial learning ability was unimpaired. The CPE-QQ mice were neither obese nor diabetic. However, they showed significantly fewer neurites in the CA3 region, the dentate gyrus of the hippocampus, and the medial prefrontal cortex, indicative of neurodegeneration. Moreover, they exhibited decreased neurogenesis in the subgranular zone and hyperphosphorylation of tau at ser<sup>395</sup>, a hallmark of AD. The studies substantiated a neuroprotective role of CPE/NF- $\alpha$ 1 in humans and identified a mutation in the *CPE* gene that can cause neurodegeneration linked to AD and perhaps other forms of dementia.

Stress also induces depression. Huda Akil's group (University of Michigan) reported that fibroblast growth factor 2 (FGF2) is an anti-depressant. We found that prolonged (6h/day for 21 days) restraint stress reduced CPE/NF- $\alpha$ 1 and FGF2 in the hippocampus of mice and induced depressive-like behavior. However, after short-term restraint stress, mice did not show depressive-like behavior despite elevated corticosterone levels indicative of stress. Moreover, hippocampal CPE/NF- $\alpha$ 1, FGF2, and doublecortin, a marker for neurogenesis, were elevated in these mice, suggesting that the anti-depressive effects of CPE/NF- $\alpha$ 1 are mediated through increased neurogenesis. Indeed, we found that exogenously applied CPE/NF- $\alpha$ 1 could up-regulate FGF2 mRNA and protein expression in cultured hippocampal neurons, indicating that CPE/NF- $\alpha$ 1 regulates FGF2 expression. CPE/NF- $\alpha$ 1-KO mice exhibited severely reduced hippocampal FGF2 levels and immature neuron numbers in the subgranular zone. The mice displayed depressive-like behavior, which was rescued by FGF2 administration. Thus, CPE/NF- $\alpha$ 1 prevents stress-induced depression by up-regulating hippocampal FGF2 expression, which leads to enhanced neurogenesis and anti-depressive activity (Reference 4). Furthermore, we found that rosiglitazone, an anti-diabetic drug, can trigger this pathway (Reference 4). Rosiglitazone has previously been shown to be effective in treating diabetic patients with bipolar disorders.

## CPE/NF-1 inhibits proliferation and induces differentiation of embryonic stem cells.

CPE/NF- $\alpha$ 1 mRNA is expressed in mouse embryos as early as day E5.5 and increases sharply at E12.5, in parallel with the development of the endocrine system, and continues to increase into adulthood. *In situ* hybridization studies indicate that CPE/NF- $\alpha$ 1 is expressed primarily in the forebrain in mouse embryos, suggesting a role of CPE/NF- $\alpha$ 1 in neurodevelopment. We therefore began studying neural stem cell proliferation. Exogenous recombinant CPE/NF- $\alpha$ 1 was added to E13.5 neocortex-derived neurospheres, which contain stem cells and neuroprogenitors. CPE/NF- $\alpha$ 1 treatment reduced the number and size of the neurospheres formed, suggesting inhibition of proliferation and maintenance of the 'stemness' of the stem

cells in the neurospheres. CPE/NF- $\alpha$ 1 down-regulated the wnt pathway in the neurospheres, leading to reduced levels of  $\beta$ -catenin, a protein known to enhance proliferation, suggesting that CPE/NF- $\alpha$ 1's inhibitory effect on proliferation is mediated by negatively regulating the wnt pathway. We carried out differentiation studies using neurospheres from seven-day cultures that were dissociated into single cells and cultured for an additional five days. We observed an increase in astrocytes in the presence of CPE/NF- $\alpha$ 1 without alteration in the percentage of neuronal and oligodendrocyte populations. Interestingly, dissociated cells from neurospheres derived from *Cpe/Nf- $\alpha$ 1-KO* mouse embryos showed fewer astrocytes but more neurons. *In vivo*, *Cpe/Nf- $\alpha$ 1-KO* mouse cortex (at P1, the time of astrocytogenesis) showed 49% fewer astrocyte numbers than in WT animals, confirming the *ex vivo* data. Our results suggest a novel role for CPE/NF- $\alpha$ 1 as an extracellular signal to inhibit proliferation and induce differentiation of neural stem cells into astrocytes, thus playing an important role in neurodevelopment (Reference 5).

Neurite outgrowth is key to the formation of synapses and the neural network during development. We found that CPE/NF- $\alpha$ 1 prevented Wnt-3a inhibition of nerve growth factor (NGF)-stimulated neurite outgrowth in PC12 cells and cortical neurons. Moreover, CPE/NF- $\alpha$ 1 augmented Wnt-5a-mediated neurite outgrowth. Thus, the interplay between NGF preventing neurite outgrowth, which is inhibited by Wnt-3a, and augmenting neurite outgrowth, which is mediated by Wnt-5a and CPE/NF- $\alpha$ 1, could play an important role in regulating these positive and negative cues, which are critical for neurodevelopment.

## Carboxypeptidase E/CPE-deltaN in tumorigenesis

Our studies indicate an important role of the CPE gene in mediating tumor growth, survival, and metastasis. We identified and cloned a novel splice isoform CPE (CPE-deltaN) mRNA, which encodes a 40kD N-terminal truncated protein that is elevated in metastatic hepatocellular, colon, breast, head, and neck carcinoma cell lines. CPE-deltaN is translocated from the cytoplasm to the nucleus of metastatic cancer cells. Overexpression of CPE-deltaN in hepatocellular carcinoma (HCC) cells promoted their proliferation and migration. In nude mice, siRNA knockdown of CPE-DN expression in highly metastatic HCC cells inhibited their growth and metastasis. CPE-deltaN promoted migration by up-regulating expression of the metastasis gene *Nedd9*, through interaction with histone deacetylase (HDAC) 1 or 2 (Reference 1). The enhanced invasive phenotype of HCC cells stably transfected with CPE-deltaN was suppressed when *Nedd9* was silenced by siRNA. Thus, CPE-deltaN plays a role in tumor metastasis. Wild-type (WT) CPE, on the other hand, plays a different role in tumor progression. In some cancer cell lines, e.g., glioma cell lines, which express and secrete WT CPE, it has been shown to enhance proliferation. However, in other cancer cells, e.g., the pancreatic cancer cell line Panc-1, which does not express WT CPE protein, there was little effect of transfected WT CPE on proliferation. *In vivo*, the interplay between CPE-deltaN and WT CPE could influence the metastatic potential of tumors.

A prospective study was carried out to evaluate the role of CPE/CPE-deltaN mRNA as a biomarker for predicting recurrence in 120 HCC patients from the Liver Network patients in Taiwan. The study focused on Stage I and II patients, given that these patients generally have better prognosis, but whose tumor recurrence rate is still high. Using the same methodology as we had published previously, we determined the Tumor/Normal (T/N) ratio of CPE/CPE-deltaN mRNA. The follow-up time ranged from 9 to 106 months. Our results demonstrated that the recurrence-free survival of HCC patients was significantly associated with CPE expression level (T/N greater than 2) for both stage I and II patients (Reference 6). The CPE/CPE mRNA expression level in HCC could therefore be a useful clinical biomarker for predicting tumor recurrence in HCC

patients who are in an early pathology stage and able to receive curative resection.

Using circulating exosomes in humans, we are also developing a blood assay to determine the CPE/CPE-deltaN biomarker levels in cancer versus normal controls. We found elevated levels of CPE/CPE-deltaN mRNA in secreted exosomes from different highly metastatic cancer cells. Even though exosome numbers themselves were not correlated with the metastatic potential of the cells, the CPE/CPE deltaN mRNA content inside the exosomes were. Thus, such a blood assay could offer a non-invasive method for the diagnosis and assessment of treatment efficacy of cancer patients.

## Publications

1. Cawley NX, Wetsel WC, Murthy SR, Park JJ, Pacak K, Loh YP. New roles of carboxypeptidase E in endocrine and neural function and cancer. *Endocr Rev* 2012 33:216-253.
2. Cheng Y, Cawley NX, Loh YP. Carboxypeptidase E/NF-alpha1: a new neurotrophic factor against oxidative stress-induced apoptotic cell death mediated by ERK and PI3-K/AKT pathways. *PLoS One* 2013 8:e71578.
3. Cheng Y, Cawley NX, Yanik T, Murthy SRK, Liu C, Kasikci F, Abebe D, Loh YP. A human carboxypeptidase E gene mutation in an Alzheimer's disease patient causes neurodegeneration, memory deficits and depression. *Translat Psychiatry* 2016 6(12):e973.
4. Cheng Y, Rodriguiz RM, Murthy SRK, Senatorov V, Thouennon E, Cawley NX, Aryal D, Ahn S, Lecka-Czernik B, Wetsel WC, Loh YP. Neurotrophic factor-alpha1 prevents stress-induced depression through enhancement of neurogenesis and is activated by rosiglitazone. *Mol Psychiatry* 2015 20:744-754.
5. Selvaraj P, Xiao L, Lee C, Murthy SRK, Cawley NX, Lane M, Merchenthaler I, Ahn S, Loh YP. Neurotrophic factor-alpha1: a key Wnt-beta-catenin dependent anti-proliferation factor and ERK-Sox9 activated inducer of embryonic neural stem cell differentiation to astrocytes in neurodevelopment. *Stem Cells* 2016; Epub ahead of print.
6. Huang S-H, Wu H-D, Chen Y-T, Murthy SR, Chiu YT, Chang Y, Chang IC, Yang X, Loh YP. Carboxypeptidase E is a prediction marker for tumor recurrence in early stage hepatocellular carcinoma. *Tumour Biol* 2016 37:9745-9753.

## Collaborators

- Soyhun Ahn, PhD, *Unit on Developmental Neurogenetics, NICHD, Bethesda, MD*
- Shiu-Feng Huang, MD PhD, *National Health Research Institutes, Zhunan, Taiwan*
- Jennifer Jones, MD PhD, *Vaccine Branch, NCI*
- Jacqueline Jonklaas, MD, *Georgetown University Medical Center, Washington, DC*
- Beata Lecka-Czernik, PhD, *University of Toledo, Toledo, OH*
- Istvan Merchenthaler, PhD, *University of Maryland, Baltimore, MD*
- Saravana Murthy, PhD, *Scanogen, Inc., Baltimore, MD*
- Karel Pacak, MD, PhD, *Section on Medical Neuroendocrinology, NICHD, Bethesda, MD*
- Joshua J. Park, PhD, *University of Toledo, Toledo, OH*
- Rina Rosin-Arbesfeld, PhD, *Sackler Faculty of Medicine, Tel Aviv University, Tel Aviv, Israel*
- Bruno Tota, MD, *Università della Calabria, Cosenza, Italy*
- Y-Ching Wang, PhD, *National Cheng Kung University, Tainin, Taiwan*

- William Wetsel, PhD, *Duke University, Durham, NC*
- Tulin Yanik, PhD, *Middle East Technical University, Ankara, Turkey*

## Contact

For more information, email [lohp@mail.nih.gov](mailto:lohp@mail.nih.gov) or visit <http://scn.nichd.nih.gov>.

## The Molecular Mechanics of Eukaryotic Translation Initiation

The goal of our research group is to elucidate the molecular mechanisms underlying the initiation phase of protein synthesis in eukaryotic organisms. We use the yeast *Saccharomyces cerevisiae* as a model system and employ a range of approaches—from genetics to biochemistry to structural biology—in collaboration with Alan Hinnebusch's and Tom Dever's labs here at NICHD and several other research groups around the world.

Eukaryotic translation initiation is a key control point in the regulation of gene expression. It begins when an initiator methionyl tRNA (Met-tRNA<sub>i</sub>) is loaded onto the small (40S) ribosomal subunit. Met-tRNA<sub>i</sub> binds to the 40S subunit as a ternary complex (TC) with the GTP-bound form of the initiation factor eIF2. Three other factors, eIF1, eIF1A, and eIF3, also bind to the 40S subunit and promote the loading of the TC. The resulting 43S pre-initiation complex (PIC) is then loaded onto the 5'-end of an mRNA with the aid of eIF3 and the eIF4 group of factors: the RNA helicase eIF4A; the 5'-7-methylguanosine cap-binding protein eIF4E; the scaffolding protein eIF4G; and the 40S subunit- and RNA-binding protein eIF4B. Both eIF4A and eIF4E bind to eIF4G and form the eIF4F complex. Once loaded onto the mRNA, the 43S PIC is thought to scan the mRNA in search of an AUG start codon. The process is ATP-dependent and likely requires several RNA helicases, including the DEAD-box protein Ded1p. Recognition of the start site begins with base pairing between the anticodon of tRNA<sub>i</sub> and the AUG codon. Base pairing then triggers downstream events that commit the PIC to continuing initiation from that point on the mRNA. These events include ejection of eIF1 from its binding site on the 40S subunit, movement of the C-terminal tail (CTT) of eIF1A, and release of phosphate from eIF2, which converts eIF2 to its GDP-bound state. In addition, the initiator tRNA moves from a position that is not fully engaged in the ribosomal P site [termed P<sub>(OUT)</sub>] to one that is [P<sub>(IN)</sub>], and the PIC as a whole converts from an open conformation that is conducive to scanning to a closed one that is not. At this stage, eIF2•GDP dissociates from the PIC, and eIF1A and a second GTPase factor, eIF5B, coordinate joining of the large ribosomal subunit to form the 80S initiation complex. In a process that appears to result in conformational reorganization of the complex, eIF5B hydrolyzes GTP and then dissociates along with eIF1A.



**Jon Lorsch, PhD**, *Chief, Laboratory on the Mechanism and Regulation of Protein Synthesis*

Jagpreet Nanda, PhD, *Staff Scientist*

Fujun Zhou, PhD, *Research Fellow*

Colin Aitken, PhD, *Postdoctoral Intramural Research Training Award Fellow*

Shardul Kulkarni, PhD, *Postdoctoral Intramural Research Training Award Fellow*

Daoming Qin, PhD, *Postdoctoral Intramural Research Training Award Fellow*

Paul Yourik, BA, *Predoctoral Intramural Research Training Award Fellow*

Charm Karunasiri, BA, *Postbaccalaureate Student*



## The molecular mechanics of eukaryotic translation initiation

We made significant progress on several fronts this year. First, we completed our studies on the roles of the domains of the eukaryotic translation initiation factor eIF3 in promoting recruitment of mRNA and initiator tRNA to the ribosomal pre-translation initiation complex (PIC). Our data indicated that the mRNA entry channel arm of eIF3 as well as its b subunit play important roles in stabilizing binding of the initiator tRNA-containing eIF2 ternary complex to the PIC and in accelerating mRNA binding. The N-terminal domain of the a subunit of eIF3 plays an important role in stabilizing mRNA binding in the exit channel (Reference 1). These studies were done in collaboration with Alan Hinnebusch and Leoš Valášek.

In our studies of the role of the RNA-activated ATPase eIF4A in promoting mRNA recruitment to the PIC, we showed that the PIC itself activates the ATPase function of the factor over and above the stimulation provided by RNA. These data indicate that eIF4A interacts with the PIC. We also showed that eIF4A and its ATPase activity enhance loading of mRNAs onto the PIC regardless of their degree of secondary structure. In addition, structures in the 5'-untranslated region (UTR) and body of the mRNA contribute in a non-additive manner to inhibiting recruitment of mRNAs to the PIC and in imposing a requirement for eIF4A. These data are in contrast to prevailing models for mRNA recruitment, which suggest that eIF4A's sole role is to unwind secondary structures in the 5'-UTRs of mRNAs. Our data indicate that eIF4A plays a key role in loading all mRNAs—even those with no expected secondary structure—and that it helps deal with the global structure of an mRNA rather than just secondary structures in the 5'-UTR. We are currently preparing a manuscript describing these studies.

We are also nearing completion of our studies of the effect of temperature on start codon recognition in yeast. We used a combination of reporter-based assays and genome-wide ribosome profiling to show that temperature affects initiation at start codons upstream of the canonical AUG in many mRNAs, but that the direction of the change is different for different messages and correlates with the length of and degree of structure in the 5'-UTR. A manuscript describing this work is planned. These studies are complemented by ribosome profiling experiments determining the genome-wide effects of mutations in translation initiation factors that increase or decrease the fidelity of start codon recognition.

In addition to these projects, we are making progress by studying the mechanism of action of the DEAD box RNA helicase Ded1p. Our work indicates that Ded1p operates in a distinct manner that depends on the mRNA being loaded onto the PIC. In collaboration with Venki Ramakrishnan's and Alan Hinnebusch's groups, we have also continued our studies on the mechanism of action of the factor eIF5 in start codon recognition. We have also started a series of high-throughput experiments to determine the mRNA features that control the rate of translation initiation in yeast.

## Additional Funding

- Funding is provided via a Memorandum of Understanding (MOU) between NIGMS and NICHD.

## Publications

1. Aitken CE, Beznosková P, Vlckova V, Chiu W-L, Zhou F, Valášek LS, Hinnebusch AG, Lorsch JR. Eukaryotic translation initiation factor 3 plays distinct roles at the mRNA entry and exit channels of the ribosomal preinitiation complex. *eLife* 2016 5: Epub ahead of print.

## Collaborators

- Thomas Dever, PhD, *Section on Protein Biosynthesis, NICHD, Bethesda, MD*
- Alan Hinnebusch, PhD, *Section on Nutrient Control of Gene Expression, NICHD, Bethesda, MD*
- Nicholas Ingolia, PhD, *University of California at Berkeley, Berkeley, CA*
- Venkatraman Ramakrishnan, PhD, *MRC Laboratory of Molecular Biology, Cambridge, United Kingdom*
- Leoš S. Valášek, PhD, *Institute of Microbiology, Czech Academy of Sciences, Prague, Czech Republic*

## Contact

For more information, email [jon.lorsch@nih.gov](mailto:jon.lorsch@nih.gov).

## Genes and Signals Regulating Mammalian Hematopoiesis

Our research focuses on the development of the mammalian hematopoietic system. Of particular interest is the characterization of signal-transduction molecules and pathways that regulate T cell maturation in the thymus. Current projects include the generation of transgenic and conditional deletion mutants to evaluate the importance of T cell antigen receptor signaling at specific stages of T cell development. We are also using microarray gene profiling to identify molecules that are important for thymocyte selection, a process that promotes the survival and further development of functional T cells and the death of auto-reactive T cells, thereby preventing autoimmunity.

A newer project involves analyzing the function of Themis, a T cell-specific signaling protein recently identified by our laboratory. Another recently initiated area of investigation focuses on hematopoietic stem cells (HSCs), which give rise to all blood cell lineages. We have begun to characterize the genes that are important for the generation and maintenance of HSCs and for their differentiation into specific hematopoietic cell types. The studies revealed a critical function for one protein (Ldb1) in controlling the self-renewal/differentiation cell-fate decision in both HSCs and erythroblasts by acting as a key component of multi-subunit DNA-binding complexes. Global (ChIP-seq) screening for Ldb1-complex DNA-binding sites identified many targets for Ldb1-mediated regulation of transcription in hematopoietic cells, demonstrating an important role for Ldb1 in hematopoietic gene regulation. Current work on Ldb1 includes an examination of a potential role for this protein in regulating self-renewal of T cell progenitors in the thymus and in the genesis of T cell Acute Lymphoblastic Leukemia (T-ALL), one of the most common childhood malignancies.

### T cell antigen receptor signaling in thymocyte development

Much of our research focuses on the role of T cell antigen receptor (TCR) signal transduction in thymocyte development. Signal transduction sequences, termed immunoreceptor tyrosine-based activation motifs or ITAMs, are contained within four distinct subunits of the multimeric TCR complex (CD3-zeta, CD3-gamma, CD3-delta, and



**Paul E. Love, MD, PhD, Head,**  
*Section on Cellular and  
Developmental Biology*

LiQi Li, MD, PhD, *Research Fellow*

Amy Palin, PhD, *Postdoctoral  
Fellow*

Claude Warzecha, PhD,  
*Postdoctoral Fellow*

Zhenhu Li, PhD, *Visiting Fellow*

Bin Zhao, PhD, *Visiting Fellow*

Dalal El-Khoury, BS, *Technician*

Jan Lee, BS, *Technician*

Miles Oliva, BS, *Postbaccalaureate  
Intramural Research Training  
Award Fellow*

Daniel Stamos, BS,  
*Postbaccalaureate Intramural  
Research Training Award Fellow*

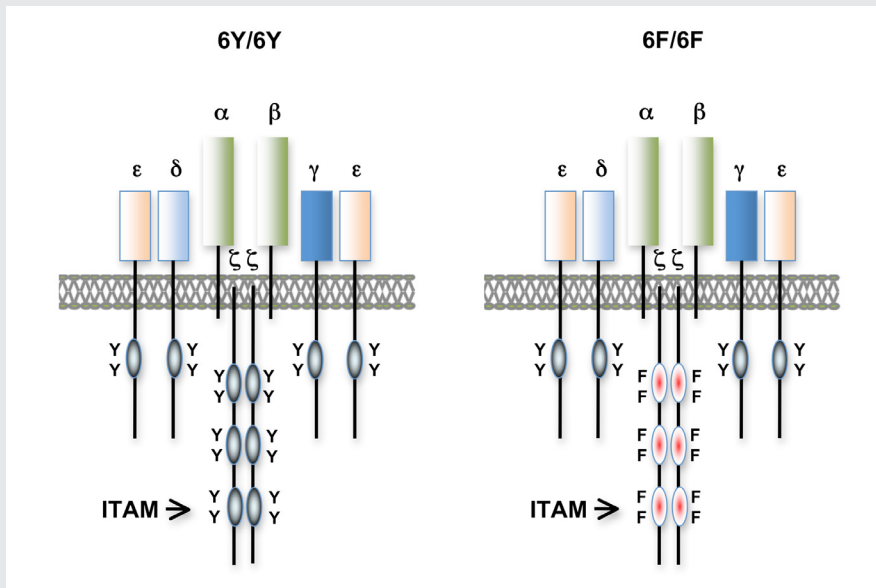

**FIGURE 1. T cell antigen receptors expressed in 6Y/6Y and 6F/6F knock-in mice**

Subunit composition of the T cell antigen receptors in 6Y/6Y and 6F/6F mice. 6Y/6Y mice express wild-type zeta chain dimers with functional ITAM signaling motifs that contain two tyrosine (Y) residues. 6F/6F mice express mutant zeta chain dimers in which the ITAM tyrosines have been changed to phenylalanine (F).

CD3-epsilon). Di-tyrosine residues within ITAMs are phosphorylated upon TCR engagement; their function is to recruit signaling molecules, such as protein tyrosine kinases, to the TCR complex, thereby initiating the T cell-activation cascade. Though conserved, ITAM sequences are nonidentical, raising the possibility that the diverse developmental and functional responses controlled by the TCR may be partly regulated by distinct ITAMs. We previously generated CD3-zeta-deficient and CD3-epsilon-deficient mice by gene targeting. We genetically reconstituted the mice with transgenes encoding wild-type or signaling-deficient (ITAM-mutant) forms of CD3-zeta and CD3-epsilon and characterized the developmental and functional consequences of the alterations for TCR signaling. We found that TCR-ITAMs are functionally equivalent but act in concert to amplify TCR signals and that TCR signal amplification is critical for thymocyte selection, the process by which potentially useful immature T cells are instructed to survive and differentiate further (positive selection) and by which potentially auto-reactive cells, which may cause auto-immune disease, are deleted in the thymus (negative selection).

Unexpectedly, we found that a complete complement of TCR-ITAMs is not required for most mature T cell effector functions. However, recent work showed a requirement for ITAM multiplicity for the generation of T follicular helper cells, which are required for optimal B cell antibody responses. One possible explanation for the relatively mild phenotype observed in the TCR ITAM-reduced mice is that ITAM-mediated signal amplification is not required for most mature T cell activation responses. Another is that, in ITAM-mutant mice, T cells exhibit normal functional responsiveness because of compensatory mechanisms imposed during development. To resolve this question, we recently generated a TCR-zeta chain conditional knockin mouse in which T cell development and selection can occur without attenuation of TCR signaling (i.e., in the presence of a wild-type 3-ITAM "6Y" zeta chain), but in which mature, post-selection T cells may be induced to express TCRs containing signaling-defective (0-ITAM "6F") zeta chains in lieu of wild-type zeta chains (Figure 1). Thus, mature T cell signaling should not be influenced by potential compensatory mechanisms that operate during T cell maturation, and T cells in these mice should be faithful indicators of the role of multiple TCR ITAMs in mediating specific, mature T cell responses. Experiments with the mice

confirmed that the knockin zeta locus functions as predicted. In the past year we conducted an extensive evaluation of T cell effector responses in 6F/6F and control, 6Y/6Y mice. Consistent with our previous data, we found that 'general' T cell responses such as cytokine production and proliferation were not significantly impaired in 6F/6F mice. However, the TCR repertoire was skewed in 6F/6F mice, as assessed by TCRValpha usage. (We stained for the spectrum of TCR alpha chain usage on mature T cells with different Valpha-specific antibodies and found that the relative percentage of each Valpha was different in the 6Y/6Y and 6F/6F mice.) Despite this, we detected no obvious 'gaps' in the antigen-reactive TCR repertoire in 6F/6F mice (i.e., 6F/6F mice were able to mount T cell responses to a variety of antigens and pathogens and contained similar numbers of naïve antigen-specific T cells as assessed by tetramer enrichment). The generation of memory T cell subsets was also unimpaired in 6F/6F mice. However, 6F/6F mice exhibited a significant impairment in the generation of follicular helper T cells (TFH). The fact that the same defect was observed in 6F/6F:B6CD45.1 bone marrow chimeras confirmed that it was intrinsic to T cells and not secondary to the elevated numbers of suppressor T cells (Tregs) in 6F/6F mice. After we had established that 6Y/6Y and 6F/6F mice contain similar numbers of naive 2W peptide (an immunogenic peptide)-reactive CD4 T-cells by tetramer enrichment, we observed the same TFH defect in mice infected with recombinant *Listeria monocytogenes* (Lm) that express a 2W peptide-OVA fusion protein (Lm-OVA), finally confirming that the defect was specifically attributable to generation of TFH cells and not a paucity of antigen-specific progenitors in 6F/6F mice. We are now using this model system to evaluate the role of ITAM multiplicity and ITAM-mediated signal amplification in T cell development, immune tolerance, and mature T cell function.

## Identification and characterization of proteins important for TCR fine tuning and TCR signaling

We extended our analysis of TCR-signaling subunits to other molecules that participate in or influence the TCR-signaling response. The cell-surface protein CD5 negatively regulates TCR signaling and functions in thymocyte selection. Examination of CD5 expression during T cell development revealed that surface levels of CD5 are regulated by TCR signal intensity and by the affinity of the TCR for self-peptide ligands in the thymus that mediate selection. To determine whether the ability to regulate CD5 expression is important for thymocyte selection, we generated transgenic mice that constitutively express high levels of CD5 throughout development. Overexpression of CD5 significantly impaired positive selection of some thymocytes (those that would normally express low levels of CD5) but not of others (those that would normally express high levels of CD5). The findings support a role for CD5 in modulating TCR signal transduction and thereby influencing the outcome of thymocyte selection. Current studies are centered on identifying the mechanism by which CD5 inhibits TCR signaling and determining whether the protein's regulated expression during development is important for preventing autoimmunity. The ability of individual thymocytes to regulate CD5 expression represents a mechanism for 'fine tuning' the TCR signaling response during development so that the integrated signaling response can be adjusted to permit T-cell functional competency without causing autoimmunity. Reasoning that, in addition to CD5, other molecules participate in TCR tuning, we initiated microarray-based screening for genes differentially expressed in developing T cells under conditions of high- or low-affinity TCR interactions. We identified several genes from this screen for further study and are validating their function as tuning molecules. Given that the molecules regulate TCR signaling, they represent potential autoimmune-disease susceptibility markers and potential targets for treatment of patients with autoimmune disease, similar to current 'checkpoint inhibitor' therapies that are based on blocking the function of the induced inhibitory molecules PD-1 and CTLA-4.

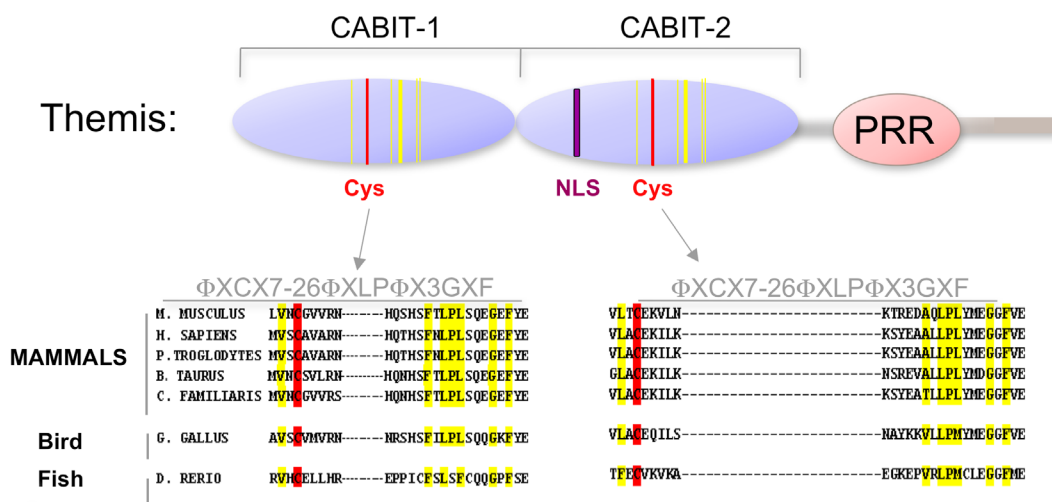
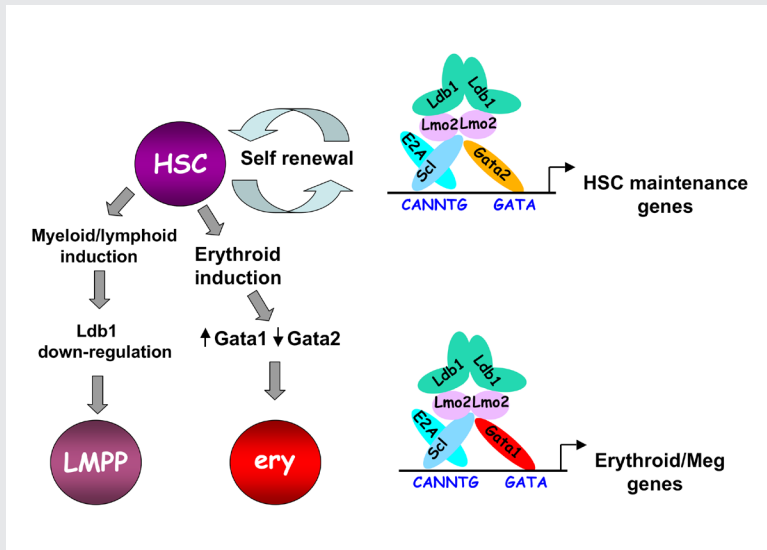

FIGURE 2. Themis is highly conserved in vertebrates.

Themis contains two novel CABIT domains, each with a conserved cysteine (red) and conserved flanking residues (yellow), a nuclear localization signal (NLS), and a proline-rich region (PRR).

## Identification and characterization of Themis, a novel protein required for T cell development

Using a subtractive cDNA library–screening approach, we recently identified Themis, now known as Themis1, a novel T cell–specific adapter protein (Figure 2). To investigate the function of Themis1 in T cell signaling and development, we generated Themis1–knockdown cell lines: Themis1 knockout mice (conventional and conditional), and Themis1–transgenic mice. Analysis of the effects of modulating Themis1 expression revealed a critical role for the protein in late T cell development. We obtained the following results. (1) The Themis1 paralog Themis2 can substitute for Themis1 in T cell development; we found that the ability of the B cell–specific family Themis member Themis2 was equivalent to that of Themis1 to restore normal T cell development in *Themis1*<sup>−/−</sup> mice, thus demonstrating functional redundancy of Themis1 and Themis2. (2) We generated retroviruses encoding domain–deletion mutants of Themis1, infected *Themis1*<sup>−/−</sup> bone marrow progenitors, and made bone marrow chimeras to determine which regions of Themis1 are important for *in vivo* function; we found that the Themis1 proline–rich sequence (PRS), which mediates binding to the signaling protein Grb2, was required for *in vivo* function, as assessed by rescue of the developmental block in *Themis1*<sup>−/−</sup> thymocytes, but that the CABIT–domain cysteines are not essential. (3) We generated *Themis2*<sup>−/−</sup> mice and began a collaboration with Richard Cornall to characterize the mice. Our results identified an important role for Themis2 in facilitating B cell activation by low avidity, but not high avidity, B cell receptor (BCR)–antigen interactions. Themis2 was required to elicit normal Ca<sup>2+</sup> and signaling via the Erk pathway in response to low–avidity interactions and was necessary for positive selection of B1 cells and germinal center B cells by self and foreign antigens. We detected Themis2 in complexes with the signaling proteins Grb2, Lyn, and PLCγ2 and found that it was required for normal tyrosine phosphorylation of Lyn and PLCγ2. This subtle but clear phenotype of *Themis2*<sup>−/−</sup> mice was not detected in a previous and less extensive study of *Themis2*<sup>−/−</sup>, which concluded that loss of Themis2 has no effect on B cell development or function.



**FIGURE 3. Model of Ldb1 function in the hematopoietic lineage**

Ldb1 forms a multimeric DNA-binding complex in hematopoietic cells with the adapter Lmo2 and the transcription factors Scl and Gata1 or Gata2. In hematopoietic stem cells (HSCs), in which Gata2 is highly expressed, Ldb1-Lmo2-Scl-Gata2 complexes positively regulate expression of HSC maintenance genes. Differentiation of HSCs to the myeloid or lymphoid lineage (LMPP) is triggered by downregulation of Ldb1, whereas commitment to the erythroid lineage (ery) is triggered by induction of Gata1 and downregulation of Gata2, resulting in the formation of an Ldb1-Lmo2-Scl-Gata1 complex, which positively regulates expression of erythroid-specific genes.

Our findings show that the impact of loss of Themis1 and Themis2 on T and B cell development, respectively, is strikingly similar. In each case, the main effect is on positive selection, which is controlled by low-avidity antigen-receptor interactions. This, together with the ability of Themis2 to rescue T cell development in *Themis1<sup>-/-</sup>* mice, indicates that Themis1 and Themis2 perform similar functions in T and B cells. Our ongoing studies are focusing on elucidating the mechanism through which Themis participates in T cell signaling and regulates T cell development.

## Role of Ldb1 transcription complexes in hematopoiesis and in T cell acute lymphoblastic leukemia

Lim domain binding protein-1 (Ldb1) is a ubiquitously expressed nuclear protein that contains a LIM-zinc finger protein-interaction motif and a dimerization domain. In hematopoietic cells, Ldb1 functions by interacting with and/or recruiting specific partners (including the LIM-only protein Lmo2 and the transcription factors SCL/Tal1 and Gata1 or Gata2) to form multi-molecular transcription complexes (Figure 3). Within the hematopoietic lineage, expression of *Ldb1* is highest in progenitor cells, which include hematopoietic stem cells (HSCs). *Ldb1*-null (*Ldb1<sup>-/-</sup>*) mice die between day 9 and 10 of gestation, preventing us from directly studying the impact of loss of Ldb1 on fetal or adult hematopoiesis. We investigated the role of Ldb1 in hematopoiesis by following the fate of *Ldb1<sup>-/-</sup>* embryonic stem cells (ESCs) in mouse blastocyst chimeras and by conditional, stage-specific deletion of *Ldb1*. Significantly, *Ldb1<sup>-/-</sup>* ESCs were capable of generating HSCs, which could give rise to both myeloid and lymphoid lineage cells; however, the number of *Ldb1<sup>-/-</sup>* HSCs gradually diminished at later stages of development. Following adoptive transfer of fetal liver hematopoietic progenitor cells, *Ldb1<sup>-/-</sup>* HSCs were rapidly lost, indicating a failure of self-renewal or survival. More recent data indicate that the loss of *Ldb1<sup>-/-</sup>* HSCs results from differentiation rather than cell death. Although expressed in ESCs, *Ldb1* expression is not required for ESC maintenance, indicating a selective requirement in adult stem cell populations. We performed a genome-wide screen for Ldb1-binding sites using ChIP-seq. Analysis of the ChIP-Seq data revealed that Ldb1 complexes bind at the promoter or regulatory sequences near a large number of genes known to be required for HSC maintenance. The data suggest that Ldb1 complexes function in a manner similar to Oct4/nanog/

Sox2, transcription factors all essential to maintaining the pluripotent ESC phenotype, in ES cells to regulate a core transcriptional network required for adult stem cell maintenance. Examination of the function of Ldb1 in lineages downstream of the HSC identified an essential function in the erythroid lineage but not in other myeloid cells or lymphoid cells. Interestingly, ChIP-Seq analysis of Ldb1 DNA-binding complexes demonstrated that, in HSCs, Ldb1 complexes contain the transcription factor Gata2 whereas, in erythroid progenitors, Ldb1 complexes contain Gata1 (which is highly expressed in the erythroid lineage). The results indicate that multimeric Ldb1 transcription complexes have distinct functions in the hematopoietic system depending on their subunit composition, with Gata2-containing complexes regulating expression of HSC-maintenance genes and Gata1 complexes regulating expression of erythroid-specific genes (Figure 3). Current studies are aimed at investigating how Ldb1 complexes regulate gene expression and the role of Ldb1 dimerization in mediating long-range promoter-enhancer interactions in hematopoietic cells. In addition, the lab is investigating a potential role for Ldb1 in regulating self-renewal of T cell progenitors in the thymus.

Acute lymphoblastic leukemias are the most common type of cancer in children. T cell acute lymphoblastic leukemia (T-ALL) results from oncogenic transformation of immature T cell progenitors (thymocytes). Mouse models of T-ALL have been generated, and one of the most informative is the *Lmo2*-transgenic (*Lmo2*-tg) mouse, which expresses high levels of the nuclear adapter Lmo2 in thymocytes. The model closely mimics a prevalent type of human T-ALL, which is associated with chromosomal mutations that result in increased expression of LMO2. We recently reported that overexpression of Lmo2 in mouse thymocytes induces T-ALL at two distinct stages of development (an early 'ETP' stage and a later 'DN3' stage). Notably, human T-ALLs can also occur at two similar stages of thymocyte maturation. The most immature forms of T-ALL in *Lmo2*-tg mice and in humans express high levels of the transcription factor *Hhex* and are designated Early T Progenitor (ETP) T-ALL, whereas later-stage tumors are low in *Hhex* but express high levels of more mature markers of T cell development, including *Notch1*, *Dtx1*, *Ptcra*, and *Hes1*. Lmo2 functions as a subunit of multimeric Ldb1-nucleated DNA binding complexes. We found that normal ETP thymocyte progenitor cells express the same Ldb1 complex subunits that are present in HSCs and that ETPs exhibit HSC characteristics, including self-renewal potential. ETPs in *Lmo2*-tg mice appear to be 'locked' into a pattern of perpetual self-renewal and are refractory to normal inductive signals that promote further differentiation. *Hhex* is a target of Ldb1 complexes in HSCs and ETPs, a result that strongly suggests that Ldb1 complexes are responsible for the aberrant self-renewal in *Lmo2*-tg mice that predisposes to oncogenesis. We hypothesize that Ldb1 complexes regulate self-renewal in ETPs as well as in HSCs. Lmo2 is normally down-regulated when thymocytes undergo T-lineage commitment, suggesting that extinguishing expression of Lmo2 (and by extension, Ldb1 complexes) is important for T cell differentiation and that failure to do so predisposes to oncogenesis via 'second-hit' transforming events.

In preliminary RNA-Seq gene expression experiments, we found that the RNA expression signatures of *Lmo2*-tg immature thymocytes and HSCs are very similar, consistent with the notion that Lmo2 overexpression 'freezes' cells in a stem cell self-renewal state. To determine whether Ldb1 complexes are in fact required for ETP self-renewal and to explore the genes regulated by these complexes, we will determine whether Ldb1 is required for *Lmo2*-tg-induced thymocyte self-renewal. Such experiments will allow us to address several key questions, including whether, as predicted, Ldb1, and by extension Ldb1 complexes, regulate expression of genes that control a self-renewal genetic program in ETPs and whether Ldb1 complexes are necessary for the transcriptional/developmental effects of Lmo2. Importantly, we will also analyze the mice for T-ALL. T-ALL formation is highly penetrant in *Lmo2*-tg mice (virtually 100% of mice develop T-ALL by one year). We



will investigate whether the timing or frequency of T-ALL is different if Ldb1 is deleted. We anticipate that these results will provide insights into the mechanisms controlling T-ALL oncogenesis in humans and may provide new therapeutic avenues for treatment of this devastating pediatric disease.

## Additional Funding

- NICHD DIR Director's Award

## Publications

1. Choi YS, Gullicksrud JA, Xing S, Zeng Z, Shan Q, Li F, Love PE, Peng W, Xue HH, Crotty S. LEF-1 and TCF-1 orchestrate TFH differentiation by regulating differentiation circuits upstream of the transcriptional repressor Bcl6. *Nat Immunol* 2015 16:980-990.
2. Hwang S, Palin AC, Li L, Song KD, Lee J, Herz J, Tubo N, Chu H, Pepper M, Lesourne R, Zvezdova E, Pinkhasov J, Jenkins MK, McGavern D, Love PE. TCR ITAM multiplicity is required for the generation of follicular helper T-cells. *Nat Commun* 2015 6:6982.
3. Cheng D, Deobagkar-Lele M, Zvezdova E, Choi S, Lesourne R, Uehara S, Baup D, Bennett SC, Bull KR, Crockford TL, Ferry H, Anzilotti C, Love PE, Cornall RJ. Themis2 lowers the threshold for B cell activation during positive selection. *Nat Immunol* 2016; in press.
4. Kitmura MY, Thomas J, Tai X, Guintier TI, Shinzawa M, Etzensperger R, Li Z, Love P, Nalayama T, Singer A. Timing and duration of MHC I positive selection signals are adjusted in the thymus to prevent lineage errors. *Nat. Immunol. Nat Immunol* 2016; in press.
5. Zvezdova E, Mikolajczak J, Garreau A, Marcellin M, Rigal L, Lee J, Choi S, Blaize G, Argenty J, Familiades J, Li L, Gonzalez de Peredo A, Burlet-Schiltz O, Love PE, Lesourne R. Themis1 enhances T cell receptor signaling during thymocyte development by promoting Vav1 activity and Grb2 stability. *Sci Signal* 2016 9(428):ra51.
6. Triplett TA, Cardenas KT, Lancaster JN, Hu Z, Selden HJ, Jasso GJ, Balasubramanyam S, Chan K, Li L, Chen X, Marcogliese AN, Dave UP, Love PE, Ehrlich LI. Endogenous dendritic cells from the tumor microenvironment support T-ALL growth via IGF1R activation. *Proc Natl Acad Sci USA* 2016 113(8):E1016-1025.

## Collaborators

- Remy Bosselut, PhD, *Laboratory of Immune Cell Biology, NCI, Bethesda, MD*
- Richard J. Cornall, FMedSci, FRCP, *University of Oxford, Oxford, United Kingdom*
- Utpal P. Davé, MD, *Vanderbilt University Medical Center, Nashville, TN*
- Lauren Ehrlich, PhD, *The University of Texas at Austin, Austin, TX*
- Marc Jenkins, PhD, *University of Minnesota, Minneapolis, MN*
- Dorian McGavern, PhD, *Viral Immunology and Intravital Imaging Section, NINDS, Bethesda, MD*
- Alfred Singer, MD, *Experimental Immunology Branch, NCI, Bethesda, MD*
- Nan-ping Weng, PhD, *Laboratory of Immunology, NIA, Baltimore, MD*

## Contact

For more information, email [lovep@mail.nih.gov](mailto:lovep@mail.nih.gov) or visit <https://irp.nih.gov/pi/paul-love>.

## Evolving Mechanisms of Transcriptional Control in Mammals

The “epigenome” refers to the heritable chemical changes in DNA and histone proteins that can be passed on through cell division and potentially across generations. Dramatic reprogramming of the epigenome begins at conception and continues throughout embryonic and postnatal development, underlying the gene-expression changes that drive the generation of diverse cell types, which make up complex multicellular organisms. By exploring transcription factors that recognize parasitic mobile DNA elements to initiate stable heterochromatic silencing, we study how the epigenetic state of mammals is initially established in early development. We also study how one large family of these parasitic elements, the endogenous retroviruses or ERVs, play an important role in development and evolution of new traits in mammals by rewiring gene expression networks. We also explore how the epigenetic state of a cell works in conjunction with combinatorial codes of transcription factors to generate the huge diversity of cell types required for mammalian development.

Retroviruses pose a threat to human health by infecting somatic cells, but retroviruses have also been infecting our mammalian ancestors for millions of years, accumulating in the germ-line as ERVs, which account for about 10% of our genomic DNA. My laboratory studies ERVs from two perspectives, as (1) as parasites that must be kept in check by the host to prevent widespread viral activation and (2) symbionts that can be co-opted by the host for evolutionary advantage. Our long-term objective is to understand how the host has adapted recognition machinery to establish epigenetic silencing of ERVs, how ERVs sometimes evade these silencing mechanisms, and how this “arms race” between ERVs and the host have led to co-option of viral regulatory sequences that likely contributed to the evolution of mammals. We hypothesize that the rapidly diversifying Krüppel-associated box–zinc finger protein (KRAB-ZFP) family of transcription factors plays a critical role in the recognition and silencing of ERVs and nearby genes, and we are taking systematic genetic and biochemical approaches to explore this function.

KRAB-ZFPs have emerged as candidates that recognize ERVs. KRAB-ZFPs are rapidly evolving transcriptional repressors that emerged in



**Todd S. Macfarlan, PhD, Head,**  
*Unit on Mammalian Epigenome  
Reprogramming*

Carson Miller, PhD, *Postdoctoral  
Fellow*

Gernot Wolf, PhD, *Visiting Fellow*

Peng Yang, PhD, *Visiting Fellow*

Sherry Ralls, BA, *Biologist*

Don Hoang, BS, *Postbaccalaureate  
Fellow*

Angela Maggio, BS,  
*Postbaccalaureate Fellow*

Matthew Tinkham, BS,  
*Postbaccalaureate Fellow*

Justin Demmerle, BA, *Graduate  
Student*

Yixuan Wang, PhD, *Collaborator*

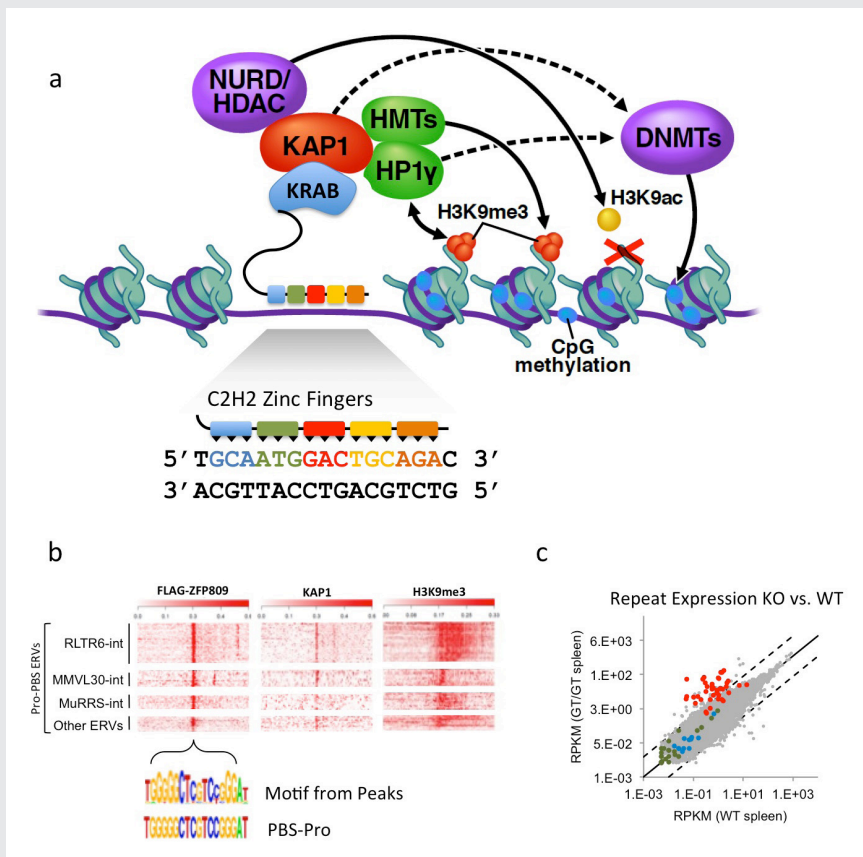

ZFP809 represses VL30<sup>Pro</sup> LTR (long-term repeat) retroelements.

a. Model of KRAB-ZFP protein function. KRAB-ZFPs consist of KRAB-repression domain that interacts with KAP1 to assemble a corepressor complex, establishing stable epigenetic silencing of targets. Tandem C2H2 zinc finger (ZF) domains mediate sequence-specific DNA interactions, with each ZF interacting with three nucleotides of target DNA.

b. Heat map plots of ChIP-seq data (with indicated antibodies) of Flag-ZFP809 peak regions. Peaks were centered on PBS<sup>Pro</sup>-like motif and grouped according to repeat masker annotation.

c. RNA-seq differential expression analysis of all repeat masker annotated elements in Zfp809 wild-type (WT) vs. knockout (KO) spleen. Red dots indicate VL30<sup>Pro</sup> elements, most of which are reactivated in KOs.

tetrapods. They make up the largest family of transcription factors in mammals (estimated to be about 200–300 in mice and humans)<sup>1</sup>. Each species has its own unique repertoire of KRAB-ZFPs, with a small number shared with closely related species and a larger fraction specific to each species. Despite their abundance, little is known about their physiological functions. KRAB-ZFPs consist of an N-terminal KRAB domain that binds to the co-repressor KAP1<sup>2</sup> and a variable number of C-terminal C2H2 zinc finger domains that mediate sequence-specific DNA binding. KAP1 directly interacts with the KRAB domain<sup>3</sup>, which recruits the histone methyltransferase SETDB1 and heterochromatin protein 1 (HP1) to initiate heterochromatic silencing<sup>4,5</sup>. Several lines of evidence point to a role for the KRAB-ZFP family in ERV silencing. First, the number of C2H2 zinc finger genes in mammals correlates with the number of ERVs<sup>6</sup>. Second, the KRAB-ZFP protein ZFP809 was isolated based on its ability to bind to the primer binding site for proline tRNA (PBS<sup>Pro</sup>) of murine leukemia virus (MuLV)<sup>7</sup>. Third, deletion of the KRAB-ZFP co-repressors *Trim28* or *Setdb1* leads to activation of many ERVs<sup>8,9</sup>. We have thus begun a systematic interrogation of KRAB-ZFP function as a potential adaptive repression system against ERVs.

We focused on ZFP809 as a likely ERV-suppressing KRAB-ZFP given that it was originally identified as part of a repression complex that recognizes infectious MuLV via direct binding to the 18 nt Primer Binding Site for Proline (PBS<sup>Pro</sup>) sequence<sup>7,10</sup>. We hypothesized that ZFP809 might function *in vivo* to repress other ERVs that utilized the PBS<sup>Pro</sup>. Using ChIP-seq of epitope-tagged ZFP809 in embryonic stem cells (ESCs) and embryonic

carcinoma (EC) cells, we determined that ZFP809 bound to several sub-classes of ERV elements via the PBS<sup>Pro</sup>. We generated *Zfp809* knockout mice to determine whether ZFP809 was required for VL30<sup>Pro</sup> (VL30 is an ERV) silencing. We found that *Zfp809* knockout tissues displayed high levels of VL30<sup>Pro</sup> elements and that the targeted elements display an epigenetic shift from repressive epigenetic marks (H3K9me3 and CpG methylation) to active marks (H3K9Ac and CpG hypo-methylation). ZFP809-mediated repression extended to a handful of genes that contained adjacent VL30<sup>Pro</sup> integrations. Furthermore, using a combination of conditional alleles and rescue experiments, we determined that ZFP809 activity was required in development to initiate silencing, but not in somatic cells to maintain silencing. The studies provided the first demonstration for the *in vivo* requirement of a KRAB-ZFP in the recognition and silencing of ERVs.

As a follow-up to our studies on ZFP809, we began a systematic analysis of KRAB-ZFPs using a medium-throughput ChIP-seq screen and functional genomics of KRAB-ZFP clusters and individual KRAB-ZFP genes. Our ChIP-seq data demonstrate that the majority of recently evolved KRAB-ZFP genes interact with and repress distinct and partially overlapping ERV targets. This is supported by a recent knockout mouse line lacking around 17 KRAB-ZFPs (generated with CRISPR/Cas9 engineering) that displays an ERV reactivation phenotype. Although our data show that many KRAB-ZFPs repress ERVs, we also found that more ancient KRAB-ZFPs that emerged in a human/mouse common ancestor do not bind to and repress ERVs. One of these KRAB-ZFPs plays an important role in silencing a key developmental gene that may have played a critical role in the onset of viviparity in mammals.

1. Urrutia R. KRAB-containing zinc-finger repressor proteins. *Genome Biol* 2003;4:231.
2. Friedman JR *et al.* KAP-1, a novel corepressor for the highly conserved KRAB repression domain. *Genes Dev* 1996;10:2067-2078.
3. Peng H *et al.* Biochemical analysis of the Kruppel-associated box (KRAB) transcriptional repression domain. *J Biol Chem* 2000;275:18000-18010.
4. Ryan RF *et al.* KAP-1 corepressor protein interacts and colocalizes with heterochromatic and euchromatic HP1 proteins: a potential role for Kruppel-associated box-zinc finger proteins in heterochromatin-mediated gene silencing. *Mol Cell Biol* 1999;19:4366-4378.
5. Schultz DC, Ayyanathan K, Negorev D, Maul GG, Rauscher FJ 3rd. SETDB1: a novel KAP-1-associated histone H3, lysine 9-specific methyltransferase that contributes to HP1-mediated silencing of euchromatic genes by KRAB zinc-finger proteins. *Genes Dev* 2002;16:919-932.
6. Thomas J H, Schneider S. Coevolution of retroelements and tandem zinc finger genes. *Genome Res* 2011;21:1800-1812.
7. Wolf D, Goff SP. Embryonic stem cells use ZFP809 to silence retroviral DNAs. *Nature* 2009;458:1201-1204.
8. Rowe HM *et al.* KAP1 controls endogenous retroviruses in embryonic stem cells. *Nature* 2010;463:237-240.
9. Matsui T *et al.* Proviral silencing in embryonic stem cells requires the histone methyltransferase ESET. *Nature* 2010;464:927-931.
10. Wolf D, Goff SP. TRIM28 mediates primer binding site-targeted silencing of murine leukemia virus in embryonic cells. *Cell* 2007;131:46-57.

## Publications

1. Wolf G, Greenberg D, Macfarlan TS. Spotting the enemy within: targeted silencing of foreign DNA in mammalian genomes by the Kruppel-associated box zinc finger protein family. *Mobile DNA* 2015 6:17.

2. Wolf G, Macfarlan TS. Revealing the complexity of retroviral repression. *Cell* 2015 163:30-32.
3. Geeven G, Zhu Y, Kim BJ, Bartholdy BA, Yang SM, Macfarlan TS, Gifford WD, Pfaff SL, Verstegen MJ, Pinto H, Vermunt MW, Creighton MP, Wijchers PJ, Stamatoyannopoulos JA, Skoultchi AI, de Laat W. Local compartment changes and regulatory landscape alterations in histone H1-depleted cells. *Genome Biol* 2015 289.
4. Wasson JA, Simon AK, Myrick DA, Wolf G, Driscoll S, Pfaff SL, Macfarlan TS, and Katz DJ. Maternally provided LSD1/KDM1A enables the maternal-to-zygotic transition and prevents defects that manifest postnatally. *eLife* 2016 e08848.
5. Thompson PJ, Macfarlan TS, Lorincz MC. Long terminal repeats: from parasitic elements to building blocks of the transcriptional regulatory repertoire. *Mol Cell* 2016 163:30-32.
6. Wang C, Lee J-E, Lai B, Macfarlan TS, Xu B, Zhuang L, Liu C, Peng W, Ge K. Enhancer priming by H4K4 methyltransferase MLL4 controls cell fate transition. *Proc Natl Acad Sci USA* 2016 113(42):11871-11876.

## Additional Funding

- Human Placenta Project (\$30K): “Quantifying placental gene expression from maternal plasma-isolated cell-free nucleic acids for real-time monitoring of placental health”

## Collaborators

- Kai Ge, PhD, *Adipocyte Biology and Gene Regulation Section, NIDDK, Bethesda, MD*
- David J. Katz, PhD, *Emory University School of Medicine, Atlanta, GA*
- Keiko Ozato, PhD, *Section on Molecular Genetics of Immunity, NICHD, Bethesda, MD*

## Contact

For more information, email [todd.macfarlan@nih.gov](mailto:todd.macfarlan@nih.gov) or visit <http://macfarlan.nichd.nih.gov>.

## Host-pathogen interactions during *Legionella pneumophila* infection

Our main research goal is to obtain mechanistic insight into the virulence strategies of microbial pathogens. As a model organism we use the bacterium *Legionella pneumophila*, the causative agent of a potentially fatal respiratory infection known as Legionnaires' disease. Contrary to what its name may imply, Legionnaires' disease occurs in individuals of all ages, including children who receive respiratory therapy, newborns who recently underwent surgery or under-water birth, and children who are immune-compromised. We are committed to an in-depth analysis of mechanisms that allow *L. pneumophila* to exploit the human host and cause disease. Insights gained from these studies will ultimately improve our ability to better diagnose, prevent, and fight Legionnaires' disease and related illnesses, thereby contributing to the success of NICHD's mission.

Upon inhalation of contaminated water droplets, *L. pneumophila* enters the lung and is phagocytosed (taken up) by alveolar macrophages, specialized immune cells. Instead of being degraded by these cells, the pathogen establishes a protective membrane compartment, the Legionella-containing vacuole (LCV). Within this intravacuolar niche, *L. pneumophila* can replicate to high numbers before killing the host cell and infecting neighboring cells.

Intracellular survival of *L. pneumophila* depends on the activity of more than 300 proteins, or effectors, that are injected into the host cell, where they create conditions favorable for infection. *L. pneumophila* mutants that are defective in effector protein delivery fail to escape endo-lysosomal degradation, underscoring the key role of microbial effectors for bacterial virulence. Our aim is to obtain a detailed mechanistic insight into the regulation and function of *L. pneumophila* effectors by investigating host-pathogen interactions at a molecular, cellular, and structural level. Deciphering the virulence program of this dangerous pathogen will set the stage for the development of novel therapeutics aimed at treating or preventing Legionnaires' disease and related illnesses.

### Host-pathogen interaction profiling using self-assembling human protein arrays

Despite many years of intense study by several groups, *L. pneumophila*



**Matthias Machner, PhD,**  
Head, Section on Microbial  
Pathogenesis

Eric Cheng, PhD, *Visiting Fellow*  
Nicole Ellis, PhD, *Visiting Fellow*  
Pei-Chung Lee, PhD, *Visiting Fellow*  
Yi-han Lin, PhD, *Visiting Fellow*  
Xiao Li, PhD, *Visiting Fellow*  
Katherine Gillis, BA,  
*Postbaccalaureate Student*

**FIGURE 1. Flow scheme of NAPPA fabrication and protein interaction assay**

NAPPA arrays are converted from DNA to protein through *in vitro* transcription/translation. Newly synthesized tagged human proteins are captured on the array by a tag-specific antibody, and binding of HaloTag-query protein to its target on NAPPA is detected using Alexa660-labeled Halo-ligand. Plasmid cDNA on the array is stained green, proteins red.

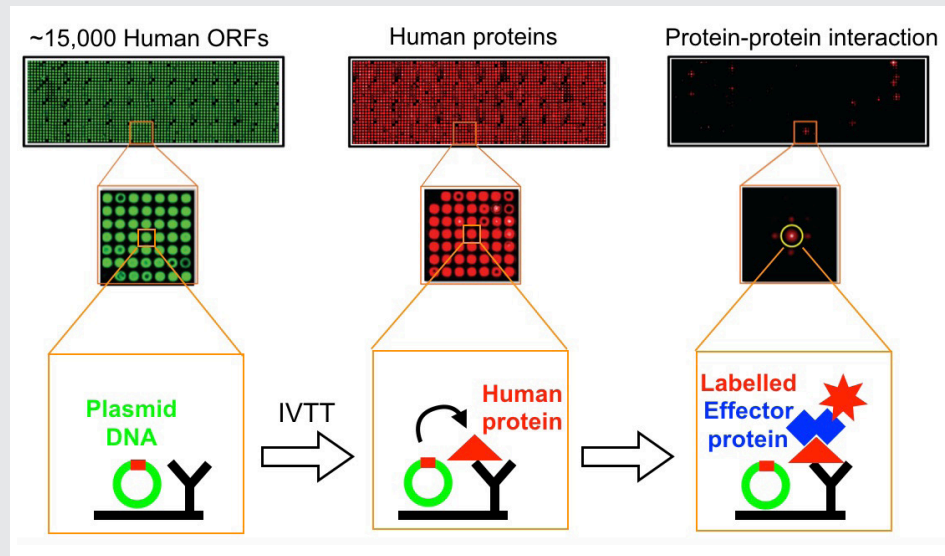

effectors of unknown function vastly outnumber those that have been well characterized. The identification of host targets has remained particularly challenging owing to the lack of simple detection tools that avoid abundance biases while providing an open format for experimental modifications. Together with the group of Joshua LaBaer, we established an improved protein-protein interaction platform called Nucleic Acid-Programmable Protein Array (NAPPA). For the array, thousands of genes encoding tagged human bait proteins are printed on an aminosilane-coated slide (Figure 2). At the time of assay, the proteins are freshly synthesized through *in vitro* transcription/translation (IVTT) and displayed *in situ* using co-spotted anti-tag antibodies.

We developed an improved NAPPA by introducing the HaloTag (Promega) at the C-terminus of the bacterial query protein. HaloTag is a modified haloalkane dehalogenase designed to covalently bind to synthetic Halo-ligands (haloalkanes). Once applied to NAPPA, binding of a HaloTag-query protein to its interactor(s) can be specifically detected among thousands of proteins using an Alexa660-labeled Halo-ligand. In a proof-of-concept study, we probed the NAPPA with the *L. pneumophila* effectors SidM or LidA and identified most of the known targets but also potential novel interaction candidates, a subset of which we confirmed in independent *in vitro* pull-down and *in vivo* cell-based assays. The NAPPA approach also facilitated the discovery of two novel interaction partners for AnkX, a *Legionella* effector protein involved in lysosomal avoidance during intracellular replication. We confirmed these interactions through both independent *in vitro* pull-down and cell-based assays. Protein truncation studies revealed that association with both host targets is mediated by the N-terminal region of AnkX, while the C-terminal region tethers AnkX to membranes. Thus, the NAPPA technology represents a platform for the easy and reliable discovery of host targets for effector proteins from *L. pneumophila*, and can be easily adapted to the study of proteins from other microbial pathogens.

## Strategy of molecular mimicry to hijack host-cell ubiquitination

Bacterial pathogens often target conserved host pathways by encoding proteins that are molecular mimics of cellular enzymes, thus tricking the host cell into surrendering its resources to the bacteria. We

**FIGURE 2. Hijacking of host ubiquitination by *Legionella* E3 ligase mimics**

Ubiquitination of target proteins is mediated by the sequential action of three types of enzyme: Ub-activating enzymes (E1s), Ub-conjugating enzymes (E2s), and Ub ligases (E3s). The E1 activates Ub in an ATP-dependent manner and transfers Ub onto an E2. From there, Ub is transferred onto a target protein by an E3 ligase, often resulting in proteasomal degradation of the target.

*Legionella* exploits the host ubiquitination machinery by producing its own E3 ligase mimics, which hijack the E2-Ub complex to target different host proteins for ubiquitination and subsequent degradation.

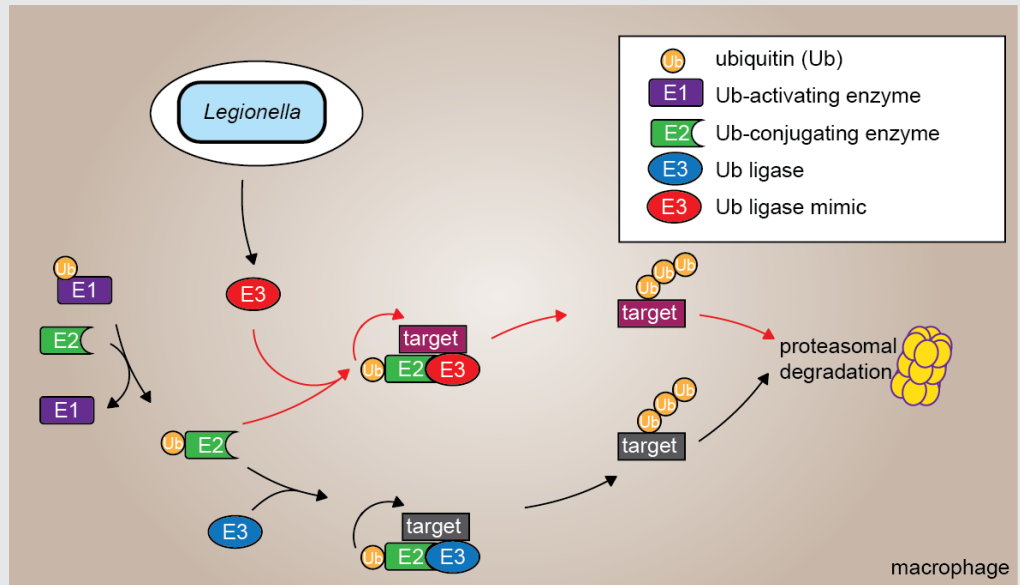

discovered that *L. pneumophila* uses such a strategy to exploit ubiquitination, a conserved post-translational modification that is mediated by a family of enzymes called E3 ubiquitin ligases. *L. pneumophila* encodes its own molecular mimics of E3 ligases, including the effector protein RavN, thereby subverting the ubiquitin pathway for its own benefit during infection. By testing truncated RavN variants in an *in vitro* reconstitution assay, we found that the E3 ligase activity of RavN is located within its N-terminal region. Using protein crystallography, we revealed that the fold of RavN shows only residual resemblance to conventional eukaryotic E3s. The N-terminal region of RavN displays a U-box-like motif that lacks the central alpha helix commonly found in other U-box domains, indicating that RavN is an E3 ligase relic that has undergone significant evolutionary alteration. Yet its mode of interaction with E2 enzymes, host proteins that are important for the ubiquitin transfer reaction, has been preserved throughout evolution, and substitution of amino acid residues within the predicted E2 binding interface have rendered RavN inactive.

Using RavN as a model for an *in silico* analysis, we discovered several additional E3 ligase mimics within the effector repertoire of *L. pneumophila* that, similar to RavN, lack significant homology to known E3s but, nonetheless, catalyze the ubiquitination reaction. Our findings support the hypothesis that E3 ligases have been a vital part of the virulence program of *L. pneumophila* and that these effectors, despite having undergone extensive evolutionary changes, have retained features that are critical for their biological function, including the ability to hijack factors that are part of the host ubiquitination machinery. These data indicate that ubiquitination is more extensively exploited during infection by *L. pneumophila* than anticipated and that interference with this post-translational modification could be a novel therapeutic strategy to antagonize infections by *L. pneumophila* and related pathogens.



## Publications

1. Lin YH, Doms AG, Cheng E, Kim B, Evans TR, Machner MP. Host cell-catalyzed S-palmitoylation mediates Golgi targeting of the Legionella ubiquitin ligase GobX. *J Biol Chem* 2015 290:25766-25781.
2. Yu X, Decker KB, Baker K, Neunuebel MR, Graves M, Westcott N, Hang H, LaBaer J, Qiu J, Machner MP. Host-pathogen interaction profiling using self-assembling human protein arrays. *J Proteome Res* 2015 14:1920-1936.
3. Machner MP, Storz G. Infection biology: small RNA with a large impact (invited commentary). *Nature* 2016 529:472-473.

## Collaborators

- Aitor Hierro, PhD, *CIC bioGUNE Institute, Bilbao, Spain*
- Joshua LaBaer, MD, PhD, *Virginia G. Piper Center for Personalized Diagnostics, Arizona State University, Tempe, AZ*

## Contact

For more information, email [machnerm@mail.nih.gov](mailto:machnerm@mail.nih.gov) or visit <http://machnerlab.nichd.nih.gov>.

## RNA Metabolism in Cell Biology, Growth, and Development

We are interested in the biogenesis and metabolism pathways for tRNAs and certain mRNAs and how these intersect with pathways related to cell proliferation, growth, and development. We focus on the synthesis of tRNAs by the RNA polymerase (RNAP) III, the early phases of their post-transcriptional handling by the RNA-binding protein La, and certain modifications that impact their translational function. The La protein is highly conserved in eukaryotic evolution and is a target of autoantibodies in (and diagnostic of) patients with Sjögren's syndrome, systemic lupus erythematosus (SLE), and neonatal lupus. It contains several nucleic acid-binding motifs as well as numerous subcellular trafficking elements and it associates with noncoding (nc) and messenger RNAs to coordinate activities in the nucleus and cytoplasm. La protein binds to the 3' oligo(U) motif common to all RNAP III transcripts and functions by protecting its RNA ligands, principally the large variety of nascent precursor tRNAs, from 3'-exonucleolytic decay and by serving as a chaperone to prevent their misfolding. In addition to its major products, the tRNAs and 5S rRNA, RNAP III also synthesizes certain other non-coding RNAs. La-related protein-4 (LARP4) interacts with the 3' poly(A) region of certain mRNAs and contributes their 3' end metabolism and translational control (Yang R *et al. Mol Cell Biol* 2011;31:542).

We focus on the tRNA-modification enzymes Trm1, which synthesizes dimethyl-guanosine-26 (m<sup>2</sup>,2G26) in several tRNAs, and tRNA isopentenyltransferase (TRIT1), which modifies tRNA by adding an isopentenyl group onto adenine at position 37 of certain tRNA (i6A37) molecules. We are examining the effects of TRIT1 on tRNA activity in translation in a codon-specific manner (Lamichhane TN *et al. Mol Cell Biol* 2013;33:4900; Lamichhane TN *et al. Mol Cell Biol* 2013;33:2918), as well as during mammalian development, and how its deficiency leads to childhood mitochondrial dysfunction and metabolic disease. We are also investigating how differences in the copy number of tRNA genes, which in humans is greater than 500 interspersed on all of the chromosomes and which indeed varies among humans (Iben JR, Maraia RJ. *Gene* 2014;536:376), can affect how the genetic code is deciphered. Tumor suppressors and oncogenes mediate deregulation of transcript production by RNAP III, the RNAP responsible for tRNA synthesis, thus contributing to increased capacity for proliferation of cancer cells.

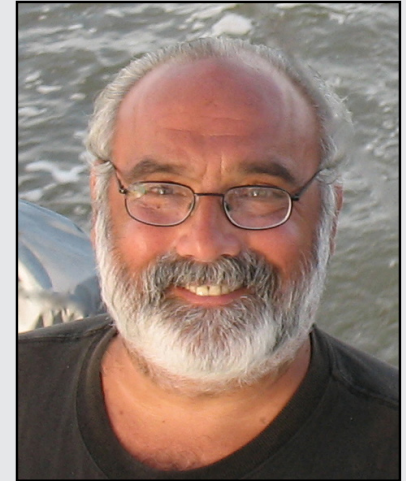

**Richard J. Maraia, MD, Head,**  
*Section on Molecular and Cellular Biology*

Sergei Gaidamakov, PhD, *Biologist*  
Sandy Mattijssen, PhD, *Research Fellow*

Nathan Blewett, PhD, *Postdoctoral Fellow*

Saurabh Mishra, PhD, *Visiting Fellow*

Keshab Rijal, PhD, *Visiting Fellow*

Alex Haddad, BS,  
*Postbaccalaureate Fellow*

We thus strive to understand the structure-function relationship and cell biology of La protein, LARP4, TRIT1, and Trm1 and their contributions to growth and development. We use genetics, cell and structural biology, and biochemistry in model systems that include yeast, human tissue culture cells, and gene-altered mice.

## Functions of the La antigen in RNA expression and mammalian cell viability

Previous findings regarding nucleolar localization, cytoplasmic splicing, and retrograde transport indicated that the tRNA production pathway is more complex in its biochemistry, spatial organization, and sequential order than previously thought. By binding to UUU-3' OH, the La protein shields newly transcribed pre-tRNAs from 3'-end digestion and functions as a chaperone for misfolded or otherwise imperfect pre-tRNAs. It has thus become clear that La serves the tRNA pathway at several levels, including protection of pre-tRNAs from 3' exonucleases; nuclear retention of pre-tRNAs, thereby preventing premature export of pre-tRNAs; and promotion of a newly identified processing step distinct from 3'-end protection.

Studies in gene-altered mice revealed that La is required for cell survival in developing B cells of the immune system and in post-mitotic cells in the cerebral cortex in the developing brain (Gaidamakov S *et al. Mol Cell Biol* 2014;34:123). Our more recent data indicate that severe loss of frontal cortex brain mass in conditional La-deleted mice is associated with perturbations in rRNA processing, and is followed by robust innate immune reactivity, including astrocyte invasion.

To study RNAP III- and La-dependent tRNA biogenesis, we developed a red-white tRNA-sensitive reporter system in the fission yeast *Schizosaccharomyces pombe* (Figure 1), a yeast that generally appears more similar to the human organism than does another yeast, *Saccharomyces cerevisiae*, with respect to cell-cycle control, gene-promoter structure, and the complexity of pre-mRNA splicing. From sequence analysis of RNAP III-transcribed genes, we predicted and then confirmed that RNAP III termination-signal recognition in *S. pombe* would be more similar to human RNAP III than it is for *S. cerevisiae* RNAP III. Our system is based on tRNA-mediated suppression of a nonsense codon in the suppressor-sensitive nonsense allele *ade6-704* and affords the benefits of fission yeast biology while lending itself to certain aspects of 'humanization.' We have been able to study the tRNA processing-associated function of the human La protein (hLa) because it is so highly conserved that it can replace the processing function of the *S. pombe* La protein Sla1p *in vivo*.

Briefly, we found that: (1) the human pattern of phosphorylation of hLa at the serine-366 target site by the protein kinase CK2 occurs faithfully in *S. pombe* and promotes tRNA production; (2) various conserved subcellular trafficking signals in La proteins can be positive or negative determinants of tRNA processing; (3) La can protect pre-tRNAs from the nuclear surveillance 3' exonuclease Rrp6p; (4) the 3' exonuclease that processes pre-tRNAs in the absence of fission yeast La protein Sla1p is distinct from Rrp6p; (5) Sla1p is limiting in *S. pombe* cells, and the extent to which it influences the use of alternative tRNA maturation pathways is balanced by the RNA 3'-5' cleavage activity of the RNAP III termination-associated RNAP III subunit Rpc11p; and (6) La proteins use distinct RNA-binding surfaces, one on the La motif (LM) and the other on the RNA recognition motif-1 (RRM1), to promote different steps in tRNA maturation.

Results of our previous work suggested that La can use several surfaces, perhaps combinatorially, to engage various classes of RNAs, e.g., pre-tRNAs versus mRNAs, or to perform different functions (Huang Y *et al.*

**FIGURE 1. The fission yeast *Schizosaccharomyces pombe* as a model organism**

Red-white colony differentiation by tRNA-mediated suppression



*Nat Struct Mol Biol* 2006;13:611; Maraia RJ, Bayfield MA. *Mol Cell* 2006;21:149). Consistent with this notion, some pre-tRNAs require only the UUU-3'OH binding activity while others depend on a second activity in addition to 3'-end protection that requires an intact RRM (RNA recognition motif) surface to promote a previously unknown step in tRNA maturation. One of our objectives is to identify cellular genes, other than that encoding La, that contribute to this 'second' activity. Toward this goal, we isolated and have begun to characterize *S. pombe* revertant mutants that overcome a defect in the second activity.

## Activities of RNA polymerase III (RNAP III) and associated factors

The RNAP III enzyme consists of 17 subunits, several with strong homology to subunits of RNAPs I and II. In addition, the transcription factor TFIIIC, composed of six subunits, binds to the A- and B-box promoters and recruits TFIIIB to direct RNAP III to the correct start site. RNAP III complexes are highly stable and demonstrate great productivity in supporting many cycles of initiation, termination, and re-initiation. For example, each of the 5S rRNA genes in human cells must produce approximately  $10^4$  to  $10^5$  transcripts per cell division to provide sufficient 5S rRNA for ribosomes. While RNAPs I, II, and III are homologous, their properties are distinct in accordance with the unique functions related to the different types of gene they transcribe. Given that some mRNA genes can be hundreds of kilobase-pairs long, RNAP II must be highly processive and avoid premature termination. RNAP II terminates in response to complex termination/RNA-processing signals that require endo-nucleolytic cleavage of RNA upstream of the elongating polymerase. By contrast, formation of the UUU-3'OH terminus of nascent RNAP III transcripts appears to occur at the RNAP III active center. The dT(n) tracts at the ends of class III genes directly signal pausing and release by RNAP III such that termination and RNA 3'-end formation are coincident and efficient (Arimbasseri AG, Maraia RJ. *Mol Cell Biol* 2013;33:1571).

Transcription termination delineates 3' ends of gene transcripts, prevents otherwise runaway RNAP from intruding into downstream genes and regulatory elements, and enables release of the RNAP for recycling. While other RNAPs require complex *cis* signals and/or accessory factors to accomplish these activities, eukaryotic RNAP III does so autonomously with high efficiency and precision at a simple oligo(dT) stretch of 5–6 bp. A basis for this high-density *cis* information is that both the template and non-template strands of the RNAP III terminator carry distinct signals for different stages of termination. High-density *cis* information is a feature of the RNAP III system that is also reflected by dual functionalities of the tRNA promoters as both DNA and RNA elements. Furthermore, the TFIIIF-like RNAP III subunit C37 is required for this function of the non-template strand signal. The results reveal the RNAP III terminator as an information-rich control element. While the template strand promotes destabilization via a weak oligo(rU:dA) hybrid, the non-template strand provides distinct sequence-specific destabilizing information through interactions with the C37 subunit.

Control of the differential abundance or activity of tRNAs can be an important determinant of gene regulation. RNAP III synthesizes all tRNAs in eukaryotes, and its derepression is associated with cancer. Maf1 is a conserved general repressor of RNAP III under the control of the target of rapamycin (TOR), which acts to integrate transcriptional output and protein-synthetic demand toward metabolic economy. We used tRNA-HydroSeq to document that little change occurred in the relative levels of different tRNAs in *maf1Δ* cells. By contrast, the efficiency of *N*<sup>2</sup>,*N*<sup>2</sup>-dimethyl G26 (m(2)2G26) modification on certain tRNAs was decreased in response to *maf1* deletion and associated with anti-suppression, which was validated by other methods. Over-expression of *Trm1*, which produces m(2)2G26, reversed *maf1* anti-suppression. A model that emerges is that competition by elevated tRNA levels in *maf1Δ* cells leads to m(2)2G26 hypomodification resulting from limiting *Trm1*, thus reducing the activity of suppressor-tRNA<sup>Ser</sup>UCA and accounting for anti-suppression. Consistent with this, RNAP III mutations associated with hypomyelinating leukodystrophy reduce tRNA transcription, increase m(2)2G26 efficiency, and reverse anti-suppression. Extending this more broadly, a reduction in tRNA synthesis by treatment with rapamycin leads to increased m(2)2G26 modification and this response is conserved among highly divergent yeasts and human cells (Arimbasseri AG *et al. PLoS Genetics* 2015;11:e1005671).

The ability of RNAP III to efficiently recycle from termination to reinitiation is critical for abundant tRNA production during cellular proliferation, development, and cancer. We used two tRNA-mediated suppression systems to screen for *Rpc1* mutants with gain- and loss- of termination phenotypes in *S. pombe*. We mapped 122 point mutation mutants to a recently solved 3.9 Å structure of the yeast RNAP III elongation complex (EC); they cluster in the active center bridge helix and trigger loop, as well as in the pore and funnel, the latter indicating involvement in termination of the RNA cleavage domain of the C11 subunit. Biochemical kinetic and genetic data indicate that mutants with the RT (readthrough) phenotype synthesize more RNA than wild-type cells, and surprisingly more than can be accounted for by their increased elongation rate. Importantly, similar mutations in spontaneous cancer suggest this as an unforeseen mechanism of RNAP III activation in disease (Reference 1).

## La-related protein-4 (LARP4) in translation-coupled mRNA stabilization

Ubiquitous in eukaryotes, the La proteins are involved in two broad functions: (1) metabolism of a wide variety of precursor tRNAs and other small nuclear RNAs by association with these RNAs' common UUU-3' OH-transcription termination elements; and (2) translation of specific subsets of mRNAs, such as those containing 5' IRES motifs. LARP4 emerged later in eukaryotic evolution and is conserved in vertebrates as a mRNA-associated cytoplasmic translation factor. We showed that the two RNA-binding motifs of LARP4, which work together as a 'La module,' exhibit preferential binding to poly(A) and are flanked on each side by a different motif that independently interacts with the poly(A)-binding protein (PABP) (Yang R *et al. Mol Cell Biol* 2011;31:542). LARP4 is controlled at the level of mRNA stability by the protein tristetrarproline (TTP) and is regulated in mammalian cells through TTP by the tumor necrosis factor alpha (TNFα) (Mattijssen S, Maraia RF. *Mol Cell Biol* 2015;36:574). LARP4 controls mRNA metabolism/homeostasis and translation.

## Fission yeast as a model system for the study of tRNA metabolism and function in translation

About 22 ago we began developing and have since been refining and advancing a tRNA-mediated suppression system in fission yeast that provides a red-white phenotypic real-time assay *in vivo*

(reviewed in Rijal K *et al. Gene* 2015;556:35). In fission yeast, the human La protein can replace the tRNA processing/maturation function of the fission yeast La protein Sla1p. Moreover, in fission yeast, human La is faithfully phosphorylated on Ser-366 by protein kinase CKII, the same enzyme that phosphorylates Ser-366 in human cells, and the phosphorylation promotes pre-tRNA processing (Intine RV *et al. Mol Cell* 2000;6:339). We use this system to study other aspects of tRNA biogenesis, including transcription by RNAP III, post-transcriptional processing, and tRNA modifications by the conserved enzymes that produce tRNA isopentenyl-adenosine-37 and dimethyl-guanosine-26. The antitumor drug rapamycin inhibits the master growth regulator and signal integrator TOR, which coordinates ribosome biogenesis and protein-synthetic capacity with nutrient homeostasis and cell-cycle progression. Rapamycin inhibits proliferation of the yeast *S. cerevisiae* and human cells, whereas proliferation of the yeast *S. pombe* is resistant to rapamycin. We found that deletion of the *tit1* gene, which encodes tRNA isopentenyltransferase, causes *S. pombe* proliferation to become sensitive to rapamycin, with a 'wee' phenotype (smaller than normal cells as a result of premature entry into mitosis), suggesting a cell-cycle defect. The gene product of *tit1* is a homolog of *S. cerevisiae* MOD5, the human tumor suppressor TRIT1, and the *Caenorhabditis elegans* life-span gene product GRO-1, enzymes that isopentenylate N6-adenine-37 (i6A37) in the anticodon loop of a small subset of tRNAs. Anticodon loop modifications are known to affect codon-specific decoding activity. Indicating a requirement for i6A37 for optimal codon-specific translation efficiency, as well as defects in carbon metabolism related to respiration, *tit1<sup>A</sup>* cells exhibit anti-suppression. Genome-wide analyses of gene-specific enrichment of codons cognate to i6A37-modified tRNAs identify genes involved in ribosome biogenesis, carbon/energy metabolism, and cell cycle genes, congruous with *tit1<sup>A</sup>* phenotypes. We found that mRNAs enriched in codons cognate to i6A37-modified tRNAs are translated less efficiently than mRNAs with low content of the cognate codons. We determined that the Tit1p-modified tRNA Tyr exhibits about five-fold higher specific decoding activity during translation than the unmodified tRNA Tyr.

## Publications

1. Rijal K, Maraia RJ. Active center control of termination by RNA polymerase III and tRNA gene transcription levels in vivo. *PLoS Genet* 2016 12:e1006253.
2. Lamichhane TN, Arimbasseri AG, Rijal K, Iben JR, Wei FY, Tomizawa K, Maraia RJ. Lack of tRNA-i6A modification causes mitochondrial-like metabolic deficiency in *S. pombe* by limiting activity of cytosolic tRNA<sup>Tyr</sup>, not mito-tRNA. *RNA* 2016 22:583-596.
3. Arimbasseri AG, Iben J, Wei FY, Rijal K, Tomizawa K, Hafner M, Maraia RJ. Evolving specificity of tRNA 3-methyl-cytidine-32 (m3C32) modification: a subset of tRNAs<sup>Ser</sup> requires N6-isopentenylolation of A37. *RNA* 2016 22:1400-1410.
4. Arimbasseri AG, Maraia RJ. RNA polymerase III advances: structural and tRNA functional views. *Trends Biochem Sci* 2016 41:546-559.
5. Arimbasseri AG, Maraia RJ. A high density of cis-information terminates RNA polymerase III on a 2-rail track. *RNA Biol* 2016 13:166-171.
6. Maraia RJ, Rijal K. Structural biology: a transcriptional specialist resolved. *Nature* 2015 528:204-205.
7. Arimbasseri AG, Maraia RJ. Mechanism of transcription termination by RNA polymerase III utilizes a non-template strand sequence-specific signal element. *Mol Cell* 2015 58:1124-1132.

## Collaborators

- Maria R. Conte, PhD, *King's College, University of London, London, UK*
- Markus Hafner, PhD, *Laboratory of Muscle Stem Cells and Gene Regulation, NIAMS, Bethesda, MD*
- James R. Iben, PhD, *Molecular Genomics Core, NICHD, Bethesda, MD*
- Robert Tylor, PhD, *Newcastle University, Newcastle, UK*

## Contact

For more information, email [maraiar@mail.nih.gov](mailto:maraiar@mail.nih.gov) or visit <http://maraiabolab.nichd.nih.gov>.

## Pathogenesis of HIV-1 and Its Copathogens in Human Tissues

The general goal of the Section of Intercellular Interactions is to understand the mechanisms of pathogenesis of various pathogens in human tissues, including the human immunodeficiency virus (HIV). Given that the critical events of this pathogenesis occur in tissues and are thus difficult to study *in vivo*, we used for our study a system of human tissues *ex vivo*, developed in our Section and now adopted by many investigators, to study viral infections and to test antivirals.

During the past year, we focused on three aims, to: (1) investigate pathogens' interactions mediated by cytokine network; (2) study HIV-1 infectivity in human tissue by analyzing individual virions' individual spikes, that mediate virus-cell fusion; (3) extend our flow-virometry technology developed for HIV-1 analysis to other viruses, in particular to Dengue virus; and (4) investigate whether the immuno-activation that we demonstrated to be the consequence of HIV-1 infection plays a role in other human diseases. The research conducted during the last year provided new insights into general mechanisms of the interaction of human pathogens with the infected host, leading to new concepts in therapeutic strategies. We investigated different modes of HIV transmission in human tissue *ex vivo*. In particular, we compared the transmission of cell-free HIV with that of HIV adsorbed at the surface of seminal cells such as monocytes and lymphocytes in a continuing project.

This year, we also continued our studies on viral pathogenesis using the nanotechnology we developed in 2015 for the analysis of individual viral particles. In particular, it became clear that together with viruses, infected cells release extracellular vesicles (EVs) that are similar in size and physical properties to viruses. We investigated the role of extracellular vesicles (EVs) in the pathogenesis of HIV and one of its major copathogens, cytomegalovirus (CMV). In particular, we identified the possible role of CMV (or EVs that carry CMV surface markers) in atherosclerosis, in particular in the destabilization of atherosclerotic plaques. We analyzed EVs in normal and in different pathologic conditions including HIV infection, acute coronary syndrome (ACS), and uveitis. We concluded that EVs may not only be a disease marker but may also mediate pathologies. Moreover, viruses and EVs have common features, including the transfer of cellular components from one cell to another.

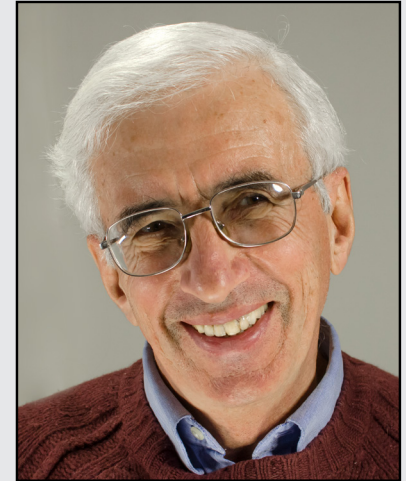

**Leonid Margolis, PhD, Head,**  
*Section on Intercellular  
Interactions*

Christophe Vanpouille, PhD, *Staff  
Scientist*

Anush Arakelyan, PhD, *Staff  
Scientist*

Rogers Nahui Palomino, BA,  
*Visiting Fellow*

Victor Silva, PhD, *Visiting Fellow*

Sonia Zicary, PhD, *Visiting Fellow*

Wendy Fitzgerald, BS, *Technician*



## Transmission of HIV from human leucocytes to cervico-vaginal tissue

The vast majority of new HIV infections occurs through sexual transmission, whereby HIV is transferred from the semen of an infected male to an uninfected partner. In semen, HIV-1 particles may exist as free-floating virions, inside infected cells, or attached to the surface of cells, whether they are infected or not. The majority of seminal cells in HIV-infected individuals carry HIV proviral DNA. We investigated whether cells carrying attached HIV on their surface can transmit infection. In particular, we investigated whether HIV attached at the surface of monocytes or lymphocytes could transmit infection to human tissue *ex vivo*. This latter system, developed in our laboratory, is close to *in vivo* and does not require artificial activation or stimulation. We irradiated monocytes and lymphocytes to prevent them from becoming infected and producing HIV, which then would act as a cell-free source of virus in our system. After washing off the unbound viruses, we quantified the amount of attached virus (by measuring p24) and incubated the cells carrying HIV on their surface with target T cells or with explants of human lymphoid tissue.

Even though comparable amounts of HIV were attached to monocytes and lymphocytes, the results of incubation of these cells with human lymphoid tissues was dramatically different. While monocytes readily transferred infection to human tissue, lymphocytes did not. Using chemotaxis chambers to physically separate irradiated monocytes carrying HIV on their surface from target cells, we found that cell-to-cell contacts were needed for effective HIV transfer.

In summary, our results show that infected and non-infected monocytes/macrophages (some of which would inevitably adsorb virus in HIV-containing semen) but not lymphocytes present in semen of HIV-infected men may adsorb virus and, together with productively infected cells, are able to transfer infection to mucosal tissues. Our results highlight the important role that seminal monocytes/macrophages may play in HIV transmission *in vivo*, especially given that monocytes/macrophages far outnumber lymphocytes in semen of HIV-infected individuals. Understanding the mechanisms of HIV-1 sexual transmission may help in designing new preventive strategies.

## Cytomegalovirus and destabilization of atherosclerotic plaques

Atherosclerosis of coronary arteries, the major cause of acute coronary syndrome (ACS), may often progress for years and even decades and then suddenly result in the rupture of an atherosclerotic plaque, leading to myocardial infarction. Despite the long history of investigation, the triggers and mechanisms of such sudden ruptures remain largely unknown. However, it is well established that immuno-activation is associated with the destabilization of atherosclerotic plaques.

We previously found that both the spectrum of lymphocytes and their activation status in plaques are different from those in blood. In particular, plaques are enriched in CD8 and CD4 T lymphocytes expressing CD25 and HLA-DR, and in effector memory lymphocytes rather than naive lymphocytes. The lymphocyte phenotypes may indicate the presence of a specific antigen, possibly of the infectious agent, toward which the lymphocytes are reactive. Herpesviruses (HHV) have been thought to be associated with atherosclerosis. However, the reports supporting such an association are controversial and, in most cases, are based on serological evidence or on the presence of cell-associated HHV DNA, but they do not provide information about actual viral replication.

To evaluate productive infection, rather than focusing on HHV replication in particular cells, we investigated,

by quantitative real-time PCR, the presence of HHV DNA of all eight types of HHV in blood samples from 71 patients with ACS, from 26 patients with stable coronary artery disease (SCAD), and from 53 healthy volunteers, as well as in atherosclerotic plaques of 22 patients with peripheral artery disease who underwent endarterectomy. The analysis revealed the presence of all eight HHV types in plasma of healthy controls and patients with ACS. HHV-5 (cytomegalovirus, CMV) was the only HHV the amount of which was higher in ACS patients than in the control group. We found that, for CMV, the DNA copy numbers in plasma positively correlated with ACS. There were no such correlations for other HHVs. With the development of our protocol of flow analysis of individual T cells in plaques, we were able to link the status of these T cells with CMV load. We demonstrated enrichment of intermediate-differentiation (CD27<sup>+</sup>-CD28<sup>+</sup>), but not late-differentiated (CD27<sup>-</sup>CD28<sup>-</sup>) T effector memory (Tem) cells. Furthermore, there were fewer naive CD4 and CD8 T cells and fewer CD4 T central memory (Tcm) cells in plaques than in blood. Our results thus indicate that only plaques with a high amount of CMV (which we found to be associated with ACS) are characterized by high levels of T cell activation. It is therefore conceivable that CMV contributes to T cell activation and triggers the rupture of these plaques.

In summary, we found that, of all HHV levels, only CMV was higher in patients with stable coronary artery disease and acute coronary syndrome than in the healthy group and that its load correlated with the level of high-sensitivity C-reactive protein. The level of CMV in atherosclerotic plaques correlated with the state of immuno-activation of lymphocytes in plaques, suggesting that the reactivation of CMV may contribute to the immune activation associated with the progression of atherosclerosis. CMV is strongly associated with the atherosclerotic process and, in particular, with ACS. In general, our results support the hypothesis that acute coronary events are synchronized with acute viral replication of CMV, possibly because of its reactivation, and that this reactivation, which may occur both at the systemic level and in plaques, may contribute to plaque destabilization.

## Extracellular vesicles in human pathologies

Membrane vesicles (extracellular vesicles, EVs) are released by almost all cells *in vivo* and *ex vivo*. The most abundant type of EV, often called “exosomes,” are lipid bilayer-enclosed entities of 50 to 100 nm containing proteins and RNA. Initially, EVs were considered to be ‘cellular dust’ or garbage and did not attract much scientific attention. However, it was recently found that EVs have an important biological function and that, in both structural and functional aspects, they resemble viruses. Published data indicate that EVs share with viruses an important function, namely delivering bioactive material from one cell to another. Therefore, the composition of EVs reflects properties of the cells that release them, can be an indicator of pathological alteration, and may play a role in the disease progression. We tested this hypothesis in two models. (1) We compared EVs in blood of healthy volunteers with those in blood of patients with acute coronary syndrome (ACS); and (2) we investigated the effect on lymphocytes and monocytes of EVs released by normal retinal cells and retinal cells treated with pro-inflammatory cytokines, which simulate the conditions typical for uveitis.

**EVs in patients with ACS.** Multiple bulk analysis studies report that the total amounts of EVs are associated with cardiovascular diseases. These bulk analyses do not reflect the individual characteristics of EVs that are released by cells of different types and activation status. Theoretically, analysis of individual EVs could reflect the pathological states of the cells of their origin, provided that they carry cellular antigens by which they can be traced to these particular cells. Using our new nanotechnology-based flow analysis, we analyzed the antigenic composition of individual EVs isolated from the blood of healthy volunteers and from the blood

of patients with acute forms of coronary artery disease, in particular myocardial infarction. Plasma EVs were captured with 15-nm magnetic nanoparticles coupled to antibodies against EVs. We chose a set of antibodies specific for antigens that, in different combinations, characterize platelet- and endothelium-derived EVs, namely CD31, CD41a, CD62E, CD63, CD105, and CD146, and we evaluated their presence on EVs isolated from blood. The total amounts of EVs were higher in the ACS patients than in the controls, predominantly owing to patients with acute myocardial infarction. For all captured fractions, the differences in the EV amounts were restricted to EVs expressing CD41a<sup>+</sup>, a platelet marker. The increase in the numbers of these EVs in the ACS patients probably reflects platelet activation and may indicate disease progression. Future studies should reveal whether the increase in the number of platelet-derived EVs precedes other symptoms of ACS; if so, this increase may be one of the early indicators of the disease and may lead to the development of new diagnostic tools.

**EVs released by human retinal cells.** Retinal pigment epithelium (RPE) cells are critical to the normal function of overlying photoreceptors and hence for normal vision. In the steady state, RPE cells possess immunosuppressive properties and presumably contribute to the inhibition of inflammatory damage to the retina. RPE cells may become damaged during degenerative or inflammatory eye diseases. Recently, RPE cells were shown to release EVs, considered to be important for intercellular communication. Using the ARPE-19 cell line, we investigated whether EVs released from RPE cells, either in homeostatic or inflammatory environments, alter T cell responses and monocyte phenotype *in vitro*. In particular, we compared the size, concentration, and immunomodulatory function of EVs released by RPE, stimulated with the inflammatory cytokines IL-1 $\beta$ , IFN- $\gamma$ , and TNF- $\alpha$ , with those released by nonstimulated RPE. Analysis by flow cytometry using human-specific antibodies revealed an approximately 3-fold higher concentration of EVs released from cytokine-stimulated RPE than from nonstimulated controls. EVs from both resting and cytokine-stimulated RPE inhibited the proliferation of T cells in peripheral blood mononuclear cell (PBMC) cultures. Importantly, RPE-derived EVs did not induce T cell death.

We next tested the ability of RPE-derived EVs to alter the phenotype and activation status of normal human monocytes. Human monocytes exposed to EVs released by nonstimulated RPE cells resulted in an enrichment of the CD14<sup>++</sup>CD16<sup>+</sup> intermediate monocyte population without affecting monocyte viability. The findings suggest that resting ARPE-19 cells, which are known to possess immunosuppressive properties, may use EVs to mediate these functions. This may represent one mechanism by which RPE cells maintain a homeostatic immunosuppressive environment to protect neighboring RPE as well as adjacent photoreceptors from inflammatory damage. However, incubation of human monocytes with EV released by cytokine-stimulated ARPE-19 cells led to monocyte cell death and upregulation of several proinflammatory cytokines. We hypothesize that the EVs released by RPE cells exposed to inflammatory conditions are modified to express proapoptotic molecules that may reduce the number of infiltrating immune cells in an attempt to abrogate immune-mediated damage to surrounding RPE cells and photoreceptors. Taken together, our results indicate that RPE cells release EVs that suppress immune responses under both resting and inflammatory conditions. Under resting conditions, RPE cells constitutively release EVs that inhibit T cell proliferation and render monocytes immunosuppressive without affecting their survival. Under inflammatory conditions, RPE release EVs that inhibit T cell proliferation without affecting T cell viability but that induce monocyte cell death, perhaps to dampen an actively destructive immune response. The results suggest that EVs secretion may be an important mechanism used by RPE cells to exert their known immunomodulatory effects.

## Additional Funding

- Office of AIDS Research (OAR), NIH, Intramural Award

## Publications

1. Barreto-de-Souza V, Arakelyan A, Zicari S, Margolis L, Vanpouille C. Monocytes but not lymphocytes carrying HIV-1 on their surface transmit infection to human tissue ex vivo. *J Virology* 2016 21:9833-9840.
2. Vanpouille C, Introini A, Morris SR, Margolis L, Daar ES, Dube MP, Little SJ, Smith DM, Lisco A, Gianella S. Distinct cytokine/chemokine network in semen and blood characterize different stages of HIV infection. *AIDS* 2016 30:193-201.
3. Zicari S, Arakelyan A, Fitzgerald W, Zaitseva E, Chernomordik LV, Margolis L, Grivel JC. Evaluation of the maturation of individual Dengue virions with flow virometry. *Virology* 2016 488:20-27.
4. Vagida M, Arakelyan A, Lebedeva A, Grivel J, Shpektor A, Vasilieva E, Margolis L. Flow analysis of individual blood extracellular vesicles in acute coronary syndrome. *Platelets* 2016 4:382-391.
5. Nikitskaya E, Lebedeva A, Ivanova O, Maryukhnich E, Shpektor A, Grivel JC, Margolis L, Vasilieva E. Cytomegalovirus-productive infection is associated with acute coronary syndrome. *J Am Heart Assoc* 2016 5(8):e003759.
6. Knickelbein JE, Liu B, Arakelyan A, Zicari S, Hannes S, Chen P, Li Z, Grivel JC, Chaigne-Delalande B, Sen HN, Margolis L, Nussenblatt RB. Modulation of immune responses by extracellular vesicles from retinal pigment epithelium. *Invest Ophthalmol Vis Sci* 2016 57:4101-4107.
7. Nolte-'t Hoen E, Cremer T, Gallo RC, Margolis LB. Extracellular vesicles and viruses: are they close relatives? *Proc Natl Acad Sci USA* 2016 113:9155-9161.

## Collaborators

- Robert Gallo, MD, *Institute of Human Virology, University of Maryland School of Medicine, Baltimore, MD*
- Jean-Charles Grivel, PhD, *Sidra Medical and Research Center, Doha, Qatar*
- Michael Lederman, MD, *Case Western University, Cleveland, OH*
- Esther Nolte-'t Hoen, PhD, *Utrecht University, Utrecht, The Netherlands*
- Robert B. Nussenblatt, MD, MPH, *Laboratory of Immunology, NEI, Bethesda, MD*
- Robin Shattock, PhD, *St. George's Hospital Medical School, University of London, UK*
- Alexandr Shpektor, MD, *Moscow Medical University, Moscow, Russia*
- Elena Vasilieva, MD, *Moscow Medical University, Moscow, Russia*

## Contact

For more information, email [margolis@helix.nih.gov](mailto:margolis@helix.nih.gov) or visit <https://irp.nih.gov/pi/leonid-margolis>.

## Genetic Disorders of Bone and Extracellular Matrix

In an integrated program of laboratory and clinical investigation, the Bone and Extracellular Matrix Branch (BEMB) studies the molecular biology of the heritable connective tissue disorders osteogenesis imperfecta (OI) and Ehlers-Danlos syndrome (EDS). Our objective is to elucidate the mechanisms by which the primary gene defect causes skeletal fragility and other connective tissue symptoms and then to apply this knowledge to the treatment of children with these conditions. Recently, we identified the long-sought cause of recessive OI. Discoveries of defects in collagen modification have generated a new paradigm for collagen-related disorders of matrix. We established that structural defects in collagen cause dominant OI while deficiency of proteins that interact with OI for folding, post-translational modification, or processing cause recessive OI. Our challenge now is to understand the cellular and biochemical mechanisms of recessive OI. We also generated a knockin murine model for OI with a classical collagen mutation as well as a murine model for recessive type IX OI and are using these models to study disease pathogenesis and the skeletal matrix of OI, the effects of pharmacological therapies, and approaches to gene therapy. Our clinical studies involve children with types II and IV OI, who form a longitudinal study group enrolled in age-appropriate clinical protocols for the treatment of their condition.

### Mechanism of rare forms of osteogenesis imperfecta (OI)

The endoplasmic reticulum (ER)-resident procollagen 3-hydroxylation complex is responsible for the 3-hydroxylation of type I collagen alpha1(I) chains. Deficiency of components of the collagen P3H (prolyl 3-hydroxylase) complex causes recessive OI. Thus, deficiency in CRTAP (cartilage-associated protein) causes type VII OI, while deficiency in P3H1 causes type VIII OI. Types VII and VIII OI are severe-to-lethal bone dysplasias that are clinically indistinguishable because the two proteins are mutually protective. For type VII OI, we are now investigating whether the transmembrane sequence at the amino end of CRTAP is in fact utilized to tether the protein to the membrane, which would be important for the coordination of collagen chain folding and modification.



**Joan C. Marini, PhD**, *Chief, Section on Heritable Disorders of Bone and Extracellular Matrix*

Aileen M. Barnes, MS, *Research Associate*

Wayne A. Cabral, PhD, *Chemist*

Simone M. Smith, PhD, *Research Fellow*

Heeseog Kang, PhD, *Postdoctoral Fellow*

Adi Reich, PhD, *Postdoctoral Fellow*

Smriti Aryal, PhD, *Visiting Fellow*

Brandi M. Owens, BA, *Postbaccalaureate Fellow*

For type VIII OI, we investigated bone and osteoblasts with collaborators Nadja Fratzi-Zelman and Cathleen Raggio. Collagen has near-absent 3-hydroxylation from both bone and dermis, demonstrating that P3H1 is the unique enzyme responsible for collagen 3-hydroxylation. Bone histomorphometry revealed decreased cortical width, very thin trabecular with patches of increased osteoid, although the overall osteoid surface was normal. Quantitative backscattered electron imaging (qBEI) showed increased mineralization of cortical and trabecular bone, as is typical of other OI types. However, the proportion of bone with low mineralization was higher in Type VIII bone than type VII, consistent with patchy osteoid in type VIII but not type VII.

The third member of the complex, Cyclophilin B (CyPB), encoded by *PP1B*, is an ER-resident peptidyl-prolyl *cis-trans* isomerase (PPIase), which functions both independently and as a component of the collagen prolyl 3-hydroxylation complex. CyPB is thought to be the major PPIase catalyzing the rate-limiting step in collagen folding. We characterized the first patient with deficiency of *PP1B*, which causes recessively inherited Type IX OI. Our group generated a *Ppib* knock-out (KO) mouse model that recapitulates the Type IX OI phenotype. Collagen from KO mouse tissue and cells is nearly lacking 3-hydroxylation. Intracellular collagen folding occurs more slowly in CyPB-null cells, supporting the enzyme's role in the rate-limiting step of folding. However, treatment of KO cells with the cyclophilin inhibitor cyclosporin A caused further delay in folding, providing support for the existence of a further collagen PPIase. We found that CyPB supports collagen lysyl hydroxylase (LH1) activity, demonstrating significantly reduced hydroxylation of the helical crosslinking residue K87, which directly affects both the extent and type of collagen intermolecular crosslinks in bone tissue. Our studies demonstrated that CyPB not only functions to regulate collagen folding and 3-hydroxylation in the ER but also indirectly regulates bone development and mechanical properties.

OI type V is caused by a recurrent dominant mutation (c.-14C>T) in *IFITM5*, which encodes BRIL, a bone-restricted interferon-induced transmembrane protein-like protein most strongly expressed in osteoblasts, which plays a role in mineralization. Patients with type V OI have distinctive clinical manifestations with overactive bone mineralization and mesh-like lamellation on bone histology. We identified eight patients with the recurrent type V OI mutation and investigated their osteoblasts in culture. The mutant Brill transcripts and protein were stable and expressed at levels comparable to control. Both early and late markers of osteoblast differentiation are elevated in type V OI osteoblasts, including the osteoblast differentiation factor Runx2, alkaline phosphatase, bone sialoprotein, osteopontin, and osteocalcin. Mineralization was also elevated in type V OI osteoblasts. However, this occurs despite the seemingly paradoxical reduction in transcripts for type I collagen in mid to late differentiation, which leads to a concomitant reduction in cross-linked collagen in matrix and an altered appearance of fibrils deposited in culture, which have a patchy rather than a network appearance. The studies demonstrated that a gain-of-function mechanism underlies type V OI and establish its collagen-related defect.

Recessive null mutations in *SERPINF1*, which encodes pigment epithelium-derived factor (PEDF), cause OI type VI. PEDF is already well-known as a potent anti-angiogenic factor. Type VI OI patients have no serum PEDF, elevated alkaline phosphatase (ALPL) as children, and bone histology with broad unmineralized osteoid and a fish-scale pattern. At first, types V and VI OI appear to be unconnected, caused by different genes, with distinct phenotypes and histology. However, we identified a patient with severe atypical type VI OI. Her osteoblasts displayed minimal secretion of PEDF, but serum PEDF was normal. *SERPINF1* sequences were normal despite bone histomorphometry typical of type VI OI, and elevated childhood serum ALPL. Surprisingly, exome sequencing on the proband, parents, and an unaffected sibling yielded a *de novo* mutation in *IFITM5* in one

allele of the proband, causing a p.S40L substitution in the BRIL intracellular domain. The *IFITM5* transcript and BRIL protein level were normal in proband fibroblasts and osteoblasts. *SERPINF1* expression and PEDF secretion were reduced in proband osteoblasts. In contrast, osteoblasts from a typical case of type V OI have elevated *SERPINF1* expression and PEDF secretion during osteoblast differentiation. Together, the data suggest that BRIL and PEDF have a relationship that connects the genes for types V and VI OI and their roles in bone mineralization. Our current studies focus on delineating the pathway connecting type V and VI OI in osteoblasts and the relationship of the angiogenic effect of PEDF to its effect on osteoblasts and bone tissue.

Recessive type XIV OI is a moderately severe bone dysplasia caused by null mutations in *TMEM38B*, which encodes TRIC-B. TRIC-B forms a monovalent cation channel in the ER membrane that is thought to counterbalance IP<sub>3</sub>R (inositol triphosphate receptor)-mediated calcium release from the ER to the cytoplasm. Using fibroblasts and osteoblasts from three independent probands, we demonstrated that TRIC-B was undetectable in their cells. Although TRIC-B is not a calcium channel, together with our NIH collaborators Yoshi Yamada and Josh Zimmerberg we showed that absence of TRIC-B results in reduced calcium flux from the ER and abnormal store-operated calcium entry, although ER steady-state calcium is normal. As expected, the disturbed calcium flux causes ER stress along the PERK pathway (involved in the unfolded protein response) and increased BiP, a regulator of ER stress. Disruption of intracellular calcium dynamics also alters the expression and activity of several collagen-modifying enzymes and chaperones in the ER. As a result, lysyl hydroxylation of the collagen helix by LH1 is reduced 30% even though LH1 levels are increased, and, conversely, hydroxylation of the telopeptide lysine by LH2 is increased, despite reduced levels of its PPIase FKBP65. Procollagen chain assembly is also delayed, likely through sequestration of protein disulfide isomerase (PDI) by calreticulin. A substantial proportion of the resulting misfolded collagen is retained in the cells, and any secreted lower-stability forms are not incorporated into matrix. These data support a role for TRIC-B in calcium homeostasis and directly connect *TMEM38B* defects to the collagen-related paradigm of OI. Other ER pathways are likely also disrupted by abnormal calcium flux in these cells, and redundancy for potassium and calcium flux likely modulates the impact of these defects on skeletal development.

In collaboration with colleagues in Thailand (Vorasuk Shotelersuk) and Switzerland (Cecilia Giunta), we identified a new OI causative gene on the X-chromosome. This is the first type of OI with X-linked inheritance, and it causes a moderate to severe bone dysplasia with pre- and postnatal fractures of ribs and long bone, bowing of long bones, low bone density, kyphoscoliosis and pectal deformities, and short stature. The affected individuals have missense mutations in *MBTPS2*, which encodes the protein S2P. S2P is a transmembrane protein in the Golgi that is a critical component of regulated membrane proteolysis (RIP). In RIP, regulatory proteins are transported from the ER membrane to the Golgi in times of cell stress or sterol depletion, where they are sequentially cleaved by S1P/S2P to release activated N-terminal fragments that enter the nucleus and activate gene transcription. Mutant S2P protein is stable but has impaired RIP functioning, with deficient cleavage of the ER stress transducers OASIS, ATF6, and SREBP. Furthermore, hydroxylation of the collagen residue K87 is reduced by half in proband bone, consistent with reduced LH in proband osteoblasts. Reduced collagen crosslinks presumably undermine bone strength. Also proband osteoblasts have broadly defective differentiation. These mutations in *MBTPS2* demonstrate that RIP plays a fundamental role in bone development as well as in cholesterol metabolism.

## C-propeptide cleavage site mutations increase bone mineralization.

Type I procollagen is processed to mature collagen by the removal of both N- and C-terminal propeptides.

The C-propeptide is cleaved at the Ala-Asp peptide bond between the telopeptide and the C-propeptide of each chain by C-proteinase/BMP-1. Probands with substitutions at the four cleavage site residues have been identified. Our investigations of two of those probands identified a High Bone Mass form of OI. These individuals have elevated bone density DEXA Z-scores and, on bone histology, patchy unmineralized osteoid. The processing of the C-propeptide from collagen secreted by proband cells is delayed. In collaboration with Adele Boskey, we found that Fourier transform infrared spectroscopy (FTIR) demonstrated a higher mineral/matrix ratio in both trabecular and cortical bone of each patient than in either age-matched normal or classical OI controls, as well as marked maturation of collagen cross-links. We extended the investigation of mineralization with BMDD (bone mineral density distribution) and BEI (backscattered electron imaging) to show that, in the alpha2(I) cleavage site mutation, the bone had a uniformly higher mineral density, while in the alpha1(I) mutation, the average mineral density was typical of classical OI but markedly more heterogeneous, with areas of very high and low bone density.

To investigate the role of the C-propeptide in bone mineralization and developmental progression, we developed a knock-in murine model with a COL1A1 cleavage site mutation. Bone collagen fibrils showed a "barbed-wire" appearance consistent with the presence of the pC-collagen that was detected in extracts of bone from mutant mice, and with impaired collagen processing *in vitro*. Impaired C-propeptide processing affects skeletal size and biomechanics. The mice are smaller than wild-type litter mates. Their femora have extreme brittleness on mechanical testing, as well as reduced fracture load. We are currently investigating bone mineralization in these mice.

## Insights from the Brtl mouse model for OI

The Brtl mouse model for OI, generated by the BEMB, is a knock-in mouse that contains a Gly349Cys substitution in the alpha1(I) chain. Brtl was modeled on a type IV OI child and accurately reproduces features of type IV OI. Brtl has provided important insights into both potential OI treatments and the mechanism of OI. First, we conducted a treatment trial of the bisphosphonate alendronate in Brtl and wild-type (WT) littermates. We found that bone density, bone volume, and trabecular number improved with treatment, as did load-to-fracture. However, detrimental side effects such as retained mineralized cartilage, reduced material properties, and altered osteoblast morphology occurred with treatment. The results reinforce the conclusion of the pediatric trial to limit the duration of bisphosphonate treatment.

Recently, we also collaborated with Kenneth Kozloff's group to investigate a potential anabolic therapy, sclerostin antibody (Scl-Ab), which stimulates osteoblasts via the canonical Wnt pathway. Scl-Ab stimulated bone formation in young Brtl mice and increased bone mass and load-to-fracture. Treatment with Scl-Ab caused no detrimental change in Brtl bone material properties. Nano-indentation studies indicating unchanged mineralization showed that the hypermineralization of bisphosphonate treatment did not occur. In addition, Scl-AB was successfully anabolic in adult Brtl mice, and may be a therapy for adult patients who have fewer treatment options.

A third therapeutic trial involving Brtl approached allele-specific silencing of the *col1a1* mutation, undertaken in collaboration with Antonella Forlino. Specific small interfering RNAs (siRNA) were evaluated *ex vivo* in Brtl fibroblasts for their effect on collagen transcripts and protein. A preferential reduction in mutant transcripts by about half was associated with a 40% decrease in mutant collagen chain. Further testing of siRNA delivered by the lentivirus might allow treatment of OI patients by autologous transplantation.



Brtl also provided important information about the cytoskeletal organization in OI osteoblasts and their potential role in the phenotypic variability of OI. Abnormal cytoskeletal organization was demonstrated to occur only in lethal pups. Comparison of lethal and surviving Brtl pups' skin/bone and bone/skin hybrid networks highlighted three proteins involved in cytoskeletal organization: vimentin, stathmin, and coffin-1. The alterations were shown to affect osteoblast proliferation, collagen deposition, integrin, and TGF-beta signaling. Furthermore, aberrant cytoskeletal assembly was detected in fibroblasts obtained from lethal, but not non-lethal, OI patients with an identical glycine substitution. The data open the possibility that cytoskeletal elements may be novel treatment targets for OI.

Two basic insights have emerged from Brtl studies. The hyper-mineralization of OI bone was previously thought to be a passive process. Altered levels for osteocyte transcripts involved in bone mineralization, such as *Dmp1* and *Sost1*, demonstrated, however, the presence of an actively directed component. Second, the osteoclast is important to the OI phenotype, with elevated numbers and TRAP (tartrate-resistant acid phosphatase) staining of osteoclasts and precursors. Co-culture experiments with Brtl and wild-type (WT) mesenchymal stem cells (MSCs) and osteoclast precursors yielded elevated osteoclast numbers from WT or Brtl precursors grown with Brtl MSCs, but not with WT MSCs. The results indicate that an osteoblast product is necessary and sufficient for elevated osteoclast numbers and could provide an important target for treatment of OI.

## Natural history and bisphosphonate treatment of children with types III and IV OI

We recently published the cardiopulmonary aspects of our natural history study on types III and IV OI in collaboration with the translational murine studies of our collaborator, Martin Hrabe de Angelis. The longitudinal evaluations were completed in 23 children with type III OI and 23 children with type IV OI, who had serial pulmonary function tests every 1–2 years. Comparison of their results with size-matched children showed a significant decline over time in pulmonary function, including lung volumes and flow rates. The decline was worse in the 36 children with scoliosis (average curve 25 degrees) but also occurred in 20 participants without scoliosis, who had declining function with restrictive disease, suggesting that the pulmonary dysfunction of OI is attributable to a primary defect in lung related to structurally abnormal collagen. The studies are important because pulmonary issues are the most prevalent cause of morbidity and mortality in OI, and affected individuals should now seek anticipatory evaluation and treatment. Currently, OI-specific growth curves are not available, despite the fact that short stature is one of the cardinal features of OI. We are now assembling our longitudinal growth data on 100 children with type III and IV OI to generate sex- and type-specific growth curves for OI. Such curves will be of great value to primary caregivers and families and will provide a baseline for treatment trials.

Our randomized controlled trial of bisphosphonate in children with types III and IV OI was the first randomized trial in the United States and one of four worldwide. Our trial examined both direct skeletal and secondary gains reported in uncontrolled trials. For skeletal outcomes, we found increased BMD Z-scores and improved vertebral area and compressions. We noted that vertebral BMD improvement tapered off after two years' treatment. Our treatment group did not experience fewer long-bone fractures, coinciding with the lack of improvement or equivocal improvement in fractures in other controlled trials. The BEMB controlled trial did not support the secondary gains claimed in observational trials, including improvement in ambulation level, lower-extremity strength, or alleviation of pain, suggesting these were placebo effects in

observational trials. Our current recommendation is treatment for 2–3 years, with subsequent follow-up of bone status. We are now engaged in a dose-comparison trial, comparing the dose from our first trial with a lower dose, achieved by increasing the cycle interval at the same dose/kg/cycle. Given the decade-long half-life and side effects of bisphosphonate on normal as well as dysplastic bone, including osteonecrosis of the jaw (ONJ), on bone healing, bone modeling, and decline in the quality of the bone material, it is important to determine the lowest cumulative dose that will provide vertebral benefits. Preliminary analysis indicates that OI children obtain benefits from lower pamidronate doses that are comparable to the benefits from higher doses.

## OI Mutation Consortium

The BEMB assembled and leads an international consortium of connective tissue laboratories for the compilation and analysis of a database of mutations in type I collagen that cause OI. The Consortium Database assembled double the previously available number of collagen mutations, and when the first analysis of the database was published in 2007, it listed over 830 mutations, including 682 glycine substitutions and 150 splice-site defects. Genotype-phenotype modeling revealed distinct functions for each alpha chain of type I collagen, including the occurrence of exclusively lethal mutations in the Major Ligand Binding Regions (MLBR) of the alpha1(I) chain on the collagen monomer and the overlapping of the regularly spaced clusters of lethal mutations along the alpha2(I) chain with the proteoglycan binding sites on the collagen fibril. The modeling for alpha2(I) supports the Regional Model for mutation that was first proposed by the BEMB over 15 years ago and now correctly predicts 86% of clinical outcomes. The Consortium Database has provided the basis for our collaborators James San Antonio and Joseph Orgel to model functional domains in terms of the cell and matrix interactions of the collagen fibril. The Consortium Database now contains over 1,570 mutations from nine international laboratories. An upcoming analysis of this database will also examine the effects of interchain salt bridges and re-nucleation residues C-terminal to the substituted glycine.

## Additional Funding

- NICHD DIR Director's Award

## Publications

1. Reich A, Bae AS, Barnes AM, Cabral WA, Hinek A, Stimee J, Hill SC, Chitayat D, Marini JC. Type V primary osteoblasts display increased mineralization despite decreased COL1A1 expression. *Metabolism* 2015 100(2):E325-332.
2. Forlino A, Marini JC. Osteogenesis Imperfecta: new forms reveal novel gene functions in bone development and unexpected protein-protein interactions. *Lancet* 387 2015 387:1657-1671.
3. Lindert U, Cabral WA, Ausavarat S, Tongkobpetch S, Ludin K, Barnes AM, Yeetong P, Weis M, Krabichler B, Srichomthong C, Makareeva E, Janecke A, Kennerknect I, Leikin S, Rothlisberger B, Rohrbach M, Eyre DR, Suphacetiporn K, Giunta C, Marini JC, Shotelersuk V. MBTPS2 mutations cause defective regulated intramembrane proteolysis in X-osteogenesis imperfecta. *Nat Commun* 2016 7:11920.
4. Cabral WA, Ishikawa M, Garten M, Makareeva EN, Sargent BM, Weis MA, Barnes AM, Webb EA, Shaw NJ, Ala-Kokko L, Lacbawan FL, Högler W, Leikin S, Blank PS, Zimmerberg J, Eyre DR, Yamada Y, Marini JC. Absence of the ER cation channel TMEM38B/TRIC-B disrupts intracellular calcium homeostasis and

- dysregulates collagen synthesis in recessive osteogenesis imperfecta. *PLoS Genetics* 2016 12(7):e1006156.
5. Fratzl-Zelman N, Barnes AM, Weis MA, Carter E, Hefferan TE, Perino G, Chang W, Smith PA, Roschger P, Klaushofer K, Glorieux F, Eyre DR, Raggio C, Rauch F, Marini JC. Non-lethal type VIII osteogenesis imperfecta has elevated bone matrix mineralization. *J Clin Endocrinol Metab* 2016 101(9):3516-3525.

## Collaborators

- Patricia Becerra, PhD, *Laboratory of Retinal Cell and Molecular Biology, NEI, Bethesda, MD*
- Adele Boskey, PhD, *Weill Medical College of Cornell University, New York, NY*
- Ehud Cohen, PhD, *The Hebrew University of Jerusalem, Jerusalem, Israel*
- Paul Coucke, PhD, *Universitair Ziekenhuis Gent, Ghent, Belgium*
- Anne De Paepe, MD, PhD, *Universitair Ziekenhuis Gent, Ghent, Belgium*
- David Eyre, PhD, *University of Washington, Seattle, WA*
- Antonella Forlino, PhD, *Università degli Studi di Pavia, Pavia, Italy*
- Nadja Fratzl-Zelman, PhD, *Ludwig Boltzmann-Institut für Osteologie, Hanusch Krankenhaus der WGKK und Unfallkrankenhaus Meidling, Vienna, Austria*
- Cecilia Giunta, PhD, *Kinderspital Zürich, Zürich, Switzerland*
- Martin Hrabe de Angelis, PhD, *Institute of Experimental Genetics, Helmholtz Zentrum München, Munich, Germany*
- Kenneth Kozloff, PhD, *University of Michigan, Ann Arbor, MI*
- Sergey Leikin, PhD, *Section on Physical Biochemistry, NICHD, Bethesda, MD*
- Katarina Lindahl, MD, *Uppsala Universitet, Uppsala, Sweden*
- Joseph Orgel, PhD, *Illinois Institute of Technology, Chicago, IL*
- Scott Paul, MD, *Rehabilitation Medicine, NIH Clinical Center, Bethesda, MD*
- Cathleen L Raggio, MD, *Weill Medical College of Cornell University, New York, NY*
- James San Antonio, PhD, *Jefferson University, Philadelphia, PA*
- Vorasuk Shotelersuk, MD, FABMG, *King Chulalongkorn Memorial Hospital, Bangkok, Thailand*
- Joseph Wallace, PhD, *University of Michigan, Ann Arbor, MI*
- Brant Weinstein, PhD, *Section on Vertebrate Organogenesis, NICHD, Bethesda, MD*
- Yoshi Yamada, PhD, *Molecular Biology Section, NIDCR, Bethesda, MD*
- Mitsuo Yamauchi, PhD, *University of North Carolina, Chapel Hill, NC*
- Joshua Zimmerberg, MD, PhD, *Section on Cellular and Membrane Biophysics, NICHD, Bethesda, MD*
- The OI Mutation Consortium, *NICHD, Bethesda, MD*

## Contact

For more information, email [marinij@mail.nih.gov](mailto:marinij@mail.nih.gov) or visit <http://www.oiprogram.nichd.nih.gov>.

## Hippocampal Interneurons and Their Role in the Control of Network Excitability

Cortical and hippocampal local-circuit GABAergic inhibitory interneurons are 'tailor-made' to control Na<sup>+</sup>- and Ca<sup>2+</sup>-dependent action potential generation, regulate synaptic transmission and plasticity, and pace large-scale synchronous oscillatory activity. The axons of this diverse cell population make local, usually short-range projections (some subpopulations project their axons over considerable distances) and release the inhibitory neurotransmitter gamma-aminobutyric acid (GABA) onto a variety of targets. A mounting appreciation of the roles played by interneurons in several mental health conditions such as epilepsy, stroke, Alzheimer's disease, and schizophrenia have placed this important cell type center stage in cortical circuit research. Our main objective is to understand the developmental programs that regulate their integration into cortical circuits and how both ionic and synaptic mechanisms regulate the activity of cortical neurons at the level of small, well defined networks. To this end, we use a variety of electrophysiological, immunohistochemical, molecular, and genetic approaches in both wild-type and transgenic animals. Over the past few years, we have continued our study on the differential mechanisms of glutamatergic and GABAergic synaptic transmission and plasticity within the hippocampal formation and the modulation of voltage- and ligand-gated channels expressed in inhibitory neurons. We also incorporate genetic approaches to unravel the embryogenesis and development of hippocampal interneurons and the circuits in which they are embedded. We are particularly interested in discovering the rules that dictate coordinated protein expression in nascent interneuron subpopulations as they migrate and integrate into the developing cortical circuit.

### Inhibitory interneurons differentially contribute to spontaneous network activity in the developing hippocampus dependent on their embryonic lineage.

Spontaneously generated network activity is a hallmark of developing neural circuits and plays an important role in the formation of synaptic connections. In the rodent hippocampus, this activity is observed *in vitro* as giant depolarizing potentials (GDPs) during the first postnatal week. Interneurons importantly



**Chris J. McBain, PhD, Head,**  
*Section on Cellular and Synaptic Physiology*

Kenneth Pelkey, PhD, *Staff Scientist*

Ramesh Chittajulla, PhD, *Senior Research Fellow*

Gulcan Akgul, PhD, *Postdoctoral Fellow*

Michael Craig, PhD, *Postdoctoral Fellow*

James D'Amour, PhD, *Postdoctoral Fellow*

Vivek Madhavan, PhD, *Postdoctoral Fellow*

Jason Wester, PhD, *Postdoctoral Fellow*

Megan Wyeth, PhD, *Postdoctoral Fellow*

Xiaoqing Yuan, MSc, *Biologist*

Steven Hunt, *Biologist*

Daniela Calvigioni, BSc, *Graduate Student*

Geoff Vargish, BS, *Graduate Student*

contribute to GDPs owing to the depolarizing actions of GABA early in development. While they are highly diverse, cortical interneurons can be segregated into two distinct groups based on their embryonic lineage from either the medial or caudal ganglionic eminences (MGE and CGE). There is evidence suggesting that CGE-derived interneurons are important for GDP generation; however, their contribution relative to those from the MGE has never been directly tested. We optogenetically inhibited either MGE- or CGE-derived interneurons in a region-specific manner in mouse neonatal hippocampus *in vitro*. In the CA1 region of the hippocampus, where interneurons are the primary source of recurrent excitation, we found that those from the MGE strongly and preferentially contributed to GDP generation. Furthermore, in dual whole-cell patch recordings in the neonatal CA1, MGE interneurons formed synaptic connections to and from neighboring pyramidal cells at a much higher rate than those from the CGE. The MGE interneurons were commonly perisomatic-targeting, in contrast to those from the CGE, which were dendrite-targeting. We also found that inhibiting MGE interneurons in CA1 suppressed GDPs in the CA3 region and vice versa; conversely, they could also trigger GDPs in CA1 that propagated to CA3 and vice versa. Our data demonstrate a key role for MGE-derived interneurons in both generating and coordinating GDPs across the hippocampus.

## Persistent inhibitory circuit defects and disrupted social behavior following *in utero* exogenous cannabinoid exposure

Placental transfer of  $\Delta^9$ -tetrahydrocannabinol (THC) during pregnancy has the potential to interfere with endogenous cannabinoid (CB) regulation of fetal nervous system development *in utero*. We examined the effect of maternal CB intake on mouse hippocampal interneurons, focusing largely on cholecystokinin-expressing interneurons (CCK-INTs), a CB subtype-1 receptor (CB1R)-expressing neuronal population prominent throughout development. Maternal treatment with THC or the synthetic CB1R agonist WIN55,212-2 (WIN) produced a significant loss of CCK-INTs in the offspring. Further, residual CCK-INTs in animals prenatally treated with WIN displayed reduced dendritic complexity. Consistent with these anatomical deficits, pups born to CB-treated dams exhibited compromised CCK-INT-mediated feedforward and feedback inhibition. Moreover, pups exposed to WIN *in utero* lacked constitutive CB1R-mediated suppression of inhibition from residual CCK-INTs and displayed altered social behavior. Our findings add to a growing list of potential cell/circuit underpinnings that may underlie cognitive impairments in offspring of mothers who abuse marijuana during pregnancy.

## Additional Funding

- Megan Wyeth was funded by a Postdoctoral Research Associate (PRAT) Fellowship.
- Jason Wester was funded by an NINDS Intramural National Research Service Award (NRSA)

## Publications

1. Wester J, McBain CJ. Inhibitory interneurons differentially contribute to spontaneous network activity in the developing hippocampus dependent on their embryonic lineage. *J Neurosci* 2016 36:2646-2662.
2. Vargish GA, Pelkey KA, Yuan X, Chittajallu R, Collins D, Fang C, McBain CJ. Persistent inhibitory circuit defects and disrupted social behavior following *in utero* exogenous cannabinoid exposure. *Mol Psychiatry* 2016 21:Epub ahead of print.
3. Peng S, Xu J, Pelkey KA, Chandra G, Zhang Z, Bagh MB, Yuan X, Wu L-G, McBain CJ, Mukherjee AB. Suppression of agrin-22 production and synaptic dysfunction in *Cln1 (-/-)* mice. *Ann Clin Transl Neurol* 2015 2:1085-1104.

## Collaborators

- Matthew Colonnese, PhD, *The George Washington University School of Medicine & Health Sciences, Washington, DC*
- Roderick McInnes, PhD, *Lady Davis Research Institute, McGill University, Montreal, Canada*
- Anil Mukherjee, PhD, *Section on Developmental Genetics, NICHD, Bethesda, MD*
- Michael Salter, PhD, *Centre for the Study of Pain, Hospital for Sick Children, Toronto, Canada*
- Paul Worley, PhD, *The Johns Hopkins University, Baltimore, MD*

## Contact

For more information, email [mcbainc@mail.nih.gov](mailto:mcbainc@mail.nih.gov) or visit <https://irp.nih.gov/pi/christopher-mcbain>.

## Childhood Neurodegenerative Lysosomal Storage Disorders

The Section on Developmental Genetics conducts both laboratory and clinical investigations into the neurodegenerative lysosomal storage disorders (LSDs) primarily affecting children. Our current research focuses on understanding the molecular mechanism(s) of pathogenesis of a group of hereditary childhood neurodegenerative LSDs called neuronal ceroid lipofuscinoses (NCLs), the most common of which is known as Batten disease. Mutations in at least 13 different genes underlie various types of NCLs, and the list continues to grow. Currently, there is no effective treatment for any of the NCL types. Among all the NCLs, infantile NCL (INCL) and congenital NCL (CNCL) are the most devastating diseases. INCL is a neurodegenerative, autosomal recessive LSD caused by mutations in the *CLN1* gene, which encodes palmitoyl-protein thioesterase-1 (PPT1), a lysosomal depalmitoylating enzyme. Numerous proteins, especially in the brain, undergo palmitoylation, which is a post-translational modification of polypeptides in which a long-chain saturated fatty acid (predominantly palmitate) is attached to specific cysteine residues. Palmitoylation (also called S-acylation) of proteins plays important roles in signal transduction pathways, and constitutive and controlled turnover of palmitate regulates membrane association and intracellular trafficking of signaling GTPases. Moreover, numerous receptors, transporters, and ion channels are S-acylated with diverse functional consequences, including protein-protein interactions, stability, and the regulation of assembly and trafficking. Palmitoylation is catalyzed by DHHC (Asp-His-His-Cys)-palmitoyl-acyltransferases (PATs), and the removal of palmitate (depalmitoylation) is catalyzed by palmitoyl-protein thioesterases (PPTs).

While S-acylation regulates the function of many important proteins requiring membrane anchorage, the proteins must also be depalmitoylated for recycling or for degradation by lysosomal hydrolases. Therefore, dynamic palmitoylation (palmitoylation-depalmitoylation), essential for steady-state membrane localization and signaling by many proteins, requires the interplay of both the DHHC-PATs and the PPTs. Several years ago, it was discovered that mutations in a lysosomal PPT1 cause accumulation of palmitoylated proteins (constituents of ceroid) in lysosomes, leading to INCL. However, the precise molecular mechanism of INCL pathogenesis

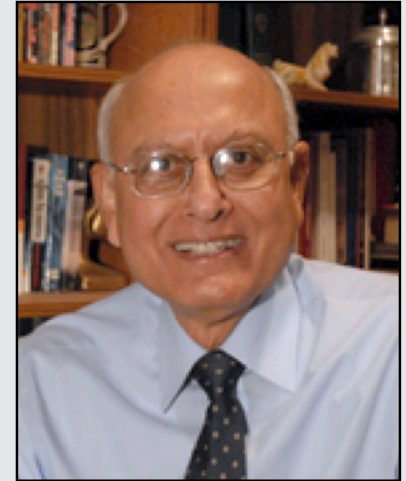

**Anil B. Mukherjee, MD, PhD,**  
*Head, Section on Developmental  
Genetics*

Zhongjian (Gary) Zhang, MD, PhD,  
*Staff Scientist*

Maria B. Bagh, PhD, *Research  
Fellow*

Arnab Datta, PhD, *Visiting Fellow*

Tamal Sadhukhan, PhD, *Visiting  
Fellow*

Ashleigh Bouchelion, PhD, *MD  
Student*

Sondra W. Levin, MD, *Adjunct  
Scientist*

remains largely unclear. Children afflicted with INCL are normal at birth, but exhibit signs of myoclonus, psychomotor retardation, and seizures followed by progressive loss of developmental milestones by 11 to 18 months of age. By two years of age, these children are completely blind as a result of retinal degeneration. At around four years of age, they fail to show any electrical activity manifested by an isoelectric electroencephalogram (EEG), including visual evoked potentials, and remain in a persistent vegetative state for several more years until death. These grim facts underscore the desirability of developing an effective therapy for this disease. Our efforts are thus directed to first understand the molecular mechanism(s) of pathogenesis through innovative laboratory investigations and, second, to apply the knowledge gained from our laboratory investigations to develop novel therapeutic strategies for INCL (CLN1 disease), juvenile NCL (JNCL or CLN3 disease), and possibly other types of Batten disease.

In our laboratory studies on INCL and JNCL, we use cultured cells from patients with these diseases as well as the mouse models (*Cln1*<sup>-/-</sup> and *Cln3*<sup>-/-</sup> mice), which recapitulate virtually all clinical and pathological features of INCL and JNCL, respectively. During the past several years, we discovered that PPT1 deficiency causes endoplasmic-reticulum (ER) and oxidative stress, which at least in part contribute to the neuropathology in INCL. Moreover, we delineated a mechanism by which PPT1 deficiency may disrupt the recycling of the synaptic vesicles (SVs), causing progressive loss of the SV pool size that is required for maintaining uninterrupted neurotransmission at nerve terminals. We also developed a noninvasive method, using MRI and MRS (magnetic resonance spectroscopy), to evaluate the progression of neurodegeneration in *Ppt1*<sup>-/-</sup> mice. The method permits repeated evaluations of potential therapeutic agents in treated animals. In addition, in collaboration with the NEI, we are conducting studies to determine whether electroretinography can be used to assess the progressive retinal deterioration in *Cln1*<sup>-/-</sup> as well as in *Cln1*-knock-in (KI) mice, which carry the most common nonsense mutation found in the INCL patient population in the US. We also discovered that the blood-brain barrier is disrupted in *Ppt1*<sup>-/-</sup> mice and that this pathology is ameliorated by treatment with resveratrol, which has anti-oxidant properties. More recently, we identified and characterized a non-toxic, thioesterase-mimetic, antioxidant small molecule, *N*-(*tert*-Butyl) hydroxylamine (NtBuHA), which mediates ceroid depletion, preserves motor function, and modestly extends lifespan of *Cln1*<sup>-/-</sup> mice. Our results suggest that thioesterase-mimetic small molecules such as NtBuHA are potential therapeutic targets for INCL. More recently, we discovered that cathepsin D (CD) deficiency in lysosomes is a common pathogenic link between INCL (CLN1 disease) and congenital NCL (CNCL) or CLN10 disease. Our current efforts are aimed at determining the common pathogenic link(s) among all NCLs.

## Discovery of a common pathogenic link between INCL and CNCL

In multicellular organisms, the lysosome is the major degradative organelle responsible for disposing of the damaged macromolecules and organelles in the cell. It has been reported that impaired lysosomal degradative capability leads to pathogenesis of many neurodegenerative disorders, including LSDs. As noted above, neurodegeneration is a devastating manifestation in the majority of the more than 50 LSDs. Moreover, lysosomal degradative capability has been reported to be impaired in several late-onset neurodegenerative diseases such as Alzheimer's, Huntington's, and Parkinson's. Cathepsin D (CD) is a major lysosomal aspartic protease in lysosomes. Lysosomal CD activity catalyzes degradation and clearance of exogenous as well as endogenous macromolecules and damaged organelles delivered to the lysosome. Intracellular accumulation of undegraded long-lived proteins and other macromolecules leads to the pathogenesis of many neurodegenerative disorders. Paradoxically, both CD overexpression and CD



### Proposed molecular model explaining how Ppt1 may catalyze V0a1 depalmitoylation on the lysosomal membrane

The model is generated by using the YCCV (tyrosine/cysteine/cysteine/valine) peptide in palmitoylated V0a1 docked into the Ppt1 active site located in its hydrophobic groove. It suggests that S-palmitoylated Cys-25, but not Cys-24, may interact with the catalytic site of Ppt1 to facilitate V0a1's depalmitoylation. The crystal structure of Ppt1 was resolved, which demonstrated the presence of the catalytic site in the hydrophobic core, through which substrates are depalmitoylated. Taken from Bellizzi JJ *et al. Proc Natl Acad Sci USA* 2000;97:4573.

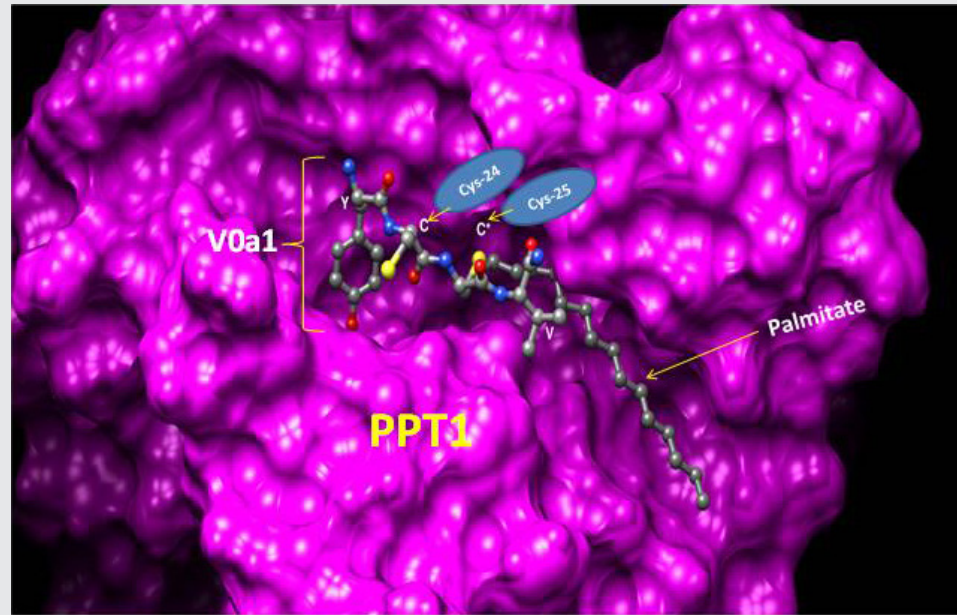

deficiency have been reported to underlie neurodegenerative diseases. However, despite intense studies, this paradox has, until now, remained poorly understood.

While inactivating mutations in the *CLN1* gene encoding palmitoyl-protein thioesterase-1 (PPT1) cause INCL, mutations in the *CLN10/CTSD* gene encoding CD underlie CNCL. We sought to determine whether there is a pathogenic link between INCL and CNCL. The synthesis of CD occurs in the ER as a pre-propeptide with a molecular mass of about 50 kDa. The cleavage of the leader peptide in the ER generates the 48 kDa precursor of mature-CD (pro-CD). In the Golgi complex, attachment of mannose 6-phosphate to pro-CD facilitates the protein's binding to endosomal/lysosomal sorting receptors. The receptor-ligand complexes then exit the trans-Golgi network in clathrin-coated intermediates and fuse with the endosomal system. The low pH of the late endosomal lumen facilitates dissociation of the receptor-ligand complexes and allows the ligand (i.e., pro-CD) to be delivered to lysosome. The pro-CD then undergoes further proteolytic cleavage by cathepsin B (CB) and cathepsin L (CL), which generate, respectively, the 31 and 14 kDa fragments, non-covalent dimerization of which constitutes the mature, catalytically active CD. We used *Cln1<sup>-/-</sup>/Ppt1<sup>-/-</sup>* mice, which recapitulate virtually all clinical and pathological features of INCL, to test for a pathogenic link between INCL and CNCL. Our results show that despite *Cln10/Ctsd* overexpression, defective processing of pro-CD to mature CD in lysosome leads to lysosomal CD deficiency causing neuropathology in INCL. Given that CD deficiency underlies CNCL, we propose that CD deficiency in the lysosome is the link between INCL and CNCL.

## MR spectroscopy to evaluate disease progression in INCL

The pathological findings for INCL include accumulation of intracellular autofluorescent material (ceroid), rapidly progressive brain atrophy resulting predominantly from loss of cortical neurons in the cerebrum, and neuro-inflammatory findings. The accumulation of ceroid is a characteristic pathological finding in all



#### Mukherjee Laboratory Staff

Upper Left to Right: Sondra W. Levin, MD; Abhilash P. Appu, PhD; Gary Zhang, MD, PhD  
 Lower Left to Right: Tamal Sadhukhan, PhD; Maria B. Bagh, PhD; Anil B. Mukherjee, MD, PhD

NCLs. Although the components and ultrastructure of the storage material vary across the different types of NCLs, electron-microscopic analyses of the brain and other tissues from INCL patients show characteristic granular osmiophilic deposits (GRODs).

Previous studies in cell cultures derived from INCL patients demonstrated that phosphocysteamine had a beneficial effect on the cell culture, resulting in depletion of intra-lysosomal ceroid deposits and suppression of apoptosis. *N*-acetylcysteine, a potent antioxidant, has been reported to have beneficial effects on other neurodegenerative diseases. Because INCL is a rare disease

(1 in over 100,000 births) with a short life expectancy, recruitment of a large study group is impractical; this consideration, together with promising results from cell-culture experiments, led to a “compassionate use” type of experimental design in which all patients received treatment with cysteamine bitartrate (Cystagon) and *N*-acetylcysteine (Mucomyst), without a control group, with the intention of comparing to the natural history and to future treatment interventions using quantifiable measures. These included behavioral and developmental assessments, EEG, ERG, MRI-derived brain volume measurements, and quantification of intra-lysosomal ceroid deposits. Towards the end of the study's recruitment period, quantitative MRS was added to the quantifiable measures. Recently, an overview of the study results was published (Reference 4), and details the quantitative MRS findings are listed below.

As part of the pilot study to evaluate treatment benefits of cysteamine bitartrate and *N*-acetylcysteine, we quantitatively measured brain metabolite levels using MRS. A subset of two patients from a larger treatment and follow-up study underwent serial quantitative single-voxel MRS examinations of five anatomical sites. Three echo times were acquired in order to estimate metabolite T2 [quantification of the absolute concentration of metabolites using long-echo-time (TE) acquisition schemes]. Measured metabolite levels included a correction for partial volume of cerebrospinal fluid. We compared INCL patients with a reference group composed of asymptomatic and minimally symptomatic Niemann-Pick disease type C patients. In INCL patients, *N*-acetylaspartate (NAA) was abnormally low at all locations upon initial measurement and further declined throughout the follow-up period. In the cerebrum (affected early in the disease course) choline and myo-inositol levels were initially elevated and fell during the follow-up period, whereas in the cerebellum and brainstem (affected later) choline and myo-inositol levels were initially normal and

rose subsequently. Choline and myo-inositol levels in our patients are consistent with patterns of neuro-inflammation observed in two INCL mouse models. Low, persistently declining NAA was expected based on the progressive, irreversible nature of the disease. Progression of metabolite levels in INCL has not been previously quantified; therefore the results of this study serve as a reference for quantitative evaluation of future therapeutic interventions.

## Brain volume measurements in INCL by MRI

Neurodegeneration is the devastating manifestation in most of the more than 50 known lysosomal storage disorders. Mutations in at least 13 different genes cause various types of NCLs. Among these genes, *CLN1*, *CLN2*, *CLN10*, and *CLN13* encode lysosomal enzymes; *CLN4* and *CLN14* encode peripherally associated cytoplasmic proteins; *CLN5* encodes a soluble lysosomal protein; *CLN11* encodes a protein in the secretory pathway; and several transmembrane proteins with varying subcellular localizations are encoded by *CLN3*, *CLN6*, *CLN7*, *CLN8*, and *CLN12*.

To evaluate the treatment benefits of the combination of cysteamine bitartrate and *N*-acetylcysteine, we made serial measurements of patients' brain volumes with MR imaging. Ten patients with infantile neuronal ceroid lipofuscinosis participating in a treatment/follow-up study underwent brain MR imaging that included high-resolution T1-weighted images. After manual placement of a mask delineating the surface of the brain, a maximum-likelihood classifier was applied to determine total brain volume, further subdivided as cerebrum, cerebellum, brain stem, and thalamus. Patients' brain volumes were compared with those of a healthy population. Major subdivisions of the brain followed similar trajectories with different timing. The cerebrum demonstrated early, rapid volume loss and may never have been normal postnatally. The thalamus dropped out of the normal range around six months of age, the cerebellum around two years of age, and the brain stem around three years of age. Rapid cerebral volume loss was expected on the basis of previous qualitative reports. Because our study did not include a non-treatment arm and because progression of brain volumes in infantile neuronal ceroid lipofuscinosis has not been previously quantified, we could not determine whether our intervention had a beneficial effect on brain volumes. However, the level of quantitative detail in this study allows it to serve as a reference for evaluation of future therapeutic interventions.

## Mechanism underlying the lysosomal acidification defect in the INCL mouse model

In eukaryotic organisms, the lysosome is the primary organelle for intracellular digestion. It contains more than 50 hydrolases, which require an acidic pH for optimal degradative function. Thus, lysosomal acidification is of fundamental importance in the degradation of macromolecules of intra- and extra-cellular origin that are delivered to the lysosome. Moreover, it has been reported that dysregulation of lysosomal acidification contributes to pathogenesis in virtually all lysosomal storage disorders (LSDs), including several NCLs. Furthermore, defective regulation of lysosomal pH has also been reported in common neurodegenerative diseases such as Alzheimer's and Parkinson's. However, despite intense studies, the mechanism(s) underlying the lysosomal acidification defect remains largely unclear.

Lysosomal acidification is regulated by vacuolar ATPase (v-ATPase), a multi-subunit protein complex composed of the cytosolic V1-sector and the lysosomal membrane-anchored V0-sector. Reversible assembly of V1/V0 sectors on the lysosomal membrane maintains functionally active v-ATPase, the proton pump of the cell, which regulates lysosomal acidification.

Palmitoylation (also called S-acylation) is a reversible post-translational modification in which a long-chain fatty acid (predominantly palmitate) is attached to specific cysteine residues in polypeptides via thioester linkage. In the mammalian genome, 23 genes encode palmitoyl-acyl-transferases (PATs), which are evolutionarily conserved, cysteine-rich proteins containing Asp-His-His-Cys (DHHC) domains that catalyze palmitoylation. In contrast, there are four thioesterases that have been characterized, two of which are cytosolic [e.g., acyl-protein thioesterase-1 (Apt1) and Apt2] and two [e.g., palmitoyl-protein thioesterase-1 (PPT1) and PPT2] are localized to the lysosome. Dynamic palmitoylation (palmitoylation-depalmitoylation), requiring coordinated action of both the DHHC-PATs and PPTs, maintain steady-state membrane localization and function of numerous important proteins, especially in the brain. By catalyzing depalmitoylation, thioesterases also facilitate recycling or degradation of proteins that undergo palmitoylation.

We tested the hypothesis that one or more subunits of v-ATPase requires S-palmitoylation for endosomal sorting, trafficking, and reversible assembly of V1/V0 on the lysosomal membrane, which is essential for regulating lysosomal pH, and that Ppt1 deficiency disrupts v-ATPase activity, impairing its proton transport function, thereby dysregulating acidification of lysosomal lumen. Our results show that the lysosomal membrane-anchored V0a1 subunit of v-ATPase undergoes S-palmitoylation, which is required for its sorting and trafficking to the lysosomal membrane. The process appears to be defective in Ppt1-deficient *Cln1*<sup>-/-</sup> mice. Notably, we demonstrated that treatment of these mice with the thioesterase (Ppt1)-mimetic small molecule NtBuHA restores v-ATPase activity and rescues defective the lysosomal acidification phenotype.

## Publications

1. Bagh MB, Peng S, Chandra G, Zhang Z, Singh SP, Pattabiraman N, Liu A, Mukherjee AB. Misrouting of v-ATPase subunit V0a1 dysregulates lysosomal acidification in a neurodegenerative lysosomal storage disease model. *Nat Commun* 2016; in press.
2. Baker EH, Levin SW, Zhang Z, Mukherjee AB. MRI brain volume measurements in infantile neuronal ceroid lipofuscinosis. *Am J Neuroradiol* 2016; Epub ahead of print.
3. Chandra G, Bagh MB, Peng S, Saha A, Sarkar C, Moralle M, Zhang Z, Mukherjee AB. *Cln1* gene disruption in mice reveals a common pathogenic link between two of the most lethal childhood neurodegenerative lysosomal storage disorders. *Hum Mol Genet* 2015 14:5416-5432.
4. Baker EH, Levin SW, Zhang Z, Mukherjee AB. Evaluation of disease progression in INCL by MR spectroscopy. *Ann Clin Transl Neurol* 2015 2:797-809.

## Collaborators

- Eva Baker, MD, PhD, *Radiology and Imaging Sciences, Clinical Center, NIH, Bethesda, MD*
- Chris J. McBain, PhD, *Section on Cellular and Synaptic Physiology, NICHD, Bethesda, MD*
- Kenneth Pelkey, PhD, *Section on Cellular and Synaptic Physiology, NICHD, Bethesda, MD*
- Ling-Gang Wu, PhD, *Synaptic Transmission Section, NINDS, Bethesda, MD*

## Contact

For more information, email [mukherja@exchange.nih.gov](mailto:mukherja@exchange.nih.gov) or visit <https://irp.nih.gov/pi/nil-mukherjee>.

## Molecular Biology, Regulation, and Biochemistry of UDP-Glucuronosyltransferase Isozymes

UDP-glucuronosyltransferase (UGT) isozymes—distributed primarily in liver, kidney, the gastrointestinal tract, and steroid-responsive tissues—are known to carry out the essential function of converting innumerable structurally diverse lipophilic endogenous substrates, such as neurotoxic bilirubin, catechol estrogens, and dihydrotestosterone, and dietary aromatic-like therapeutics to water-soluble excretable glucuronides. Most importantly, environmental pro-carcinogens and contaminants derived from pyrolysates are converted to avoid chemical toxicities. Our studies demonstrated that each UGT isozyme so far examined requires ongoing regulated phosphate signaling, which enables an active site to convert an unspecified number of substrates. Recently, further studies showed that the human prostate luminal-cell UGT-2B15 and basal-cell UGT-2B17, which are 97% identical, have an additional Src or Src/PKC $\epsilon$ -partnership phosphorylation site, respectively, at position 98–100. We found that the two isozymes exhibit opposite behavior when their Src sites are compromised: UGT-2B15 becomes polyubiquitinated, thus exhibiting a pro-apoptotic effect, while the activity of UGT-2B17 is elevated by 50%. Our studies will thus continue to detail and understand the specific reactions involved in human prostate-luminal cell apoptosis and de-ubiquitination. In collaboration with ongoing research within the NCI, NIDCR, and with researchers at the University of Maryland, we will also carry out basic studies to better understand prostate cancer development.

### Pro- and anti-apoptotic sequences control human prostate DHT-metabolizing UGT-2B15 and UGT-2B17

Similar to each of the 6 of 19 UGTs examined, UGT-2B17 requires PKC $\alpha$ -mediated phosphorylation signaling at position 172, which enables catalysis of an unspecified number of substrates, according to the 6 of 19 human UGTs examined. Moreover, mass spectrometry confirmed that UGT-2B17 has the triple-phosphorylated sequence threonine/tyrosine/serine (TYS) at positions 98–100. Notably, analyses of anti-PKC $\alpha$ -immunocomplexed wild-type (wt) UGT-2B17 and its 4-phosphorylated anti-PKC $\epsilon$ -immunocomplexes of UGT-2B17 show a dense smearing pattern, except in the case of its Y99F (tyrosine→phenylalanine) mutant or following expression of



Ida S. Owens, PhD, Head, Section on Genetic Disorders of Drug Metabolism

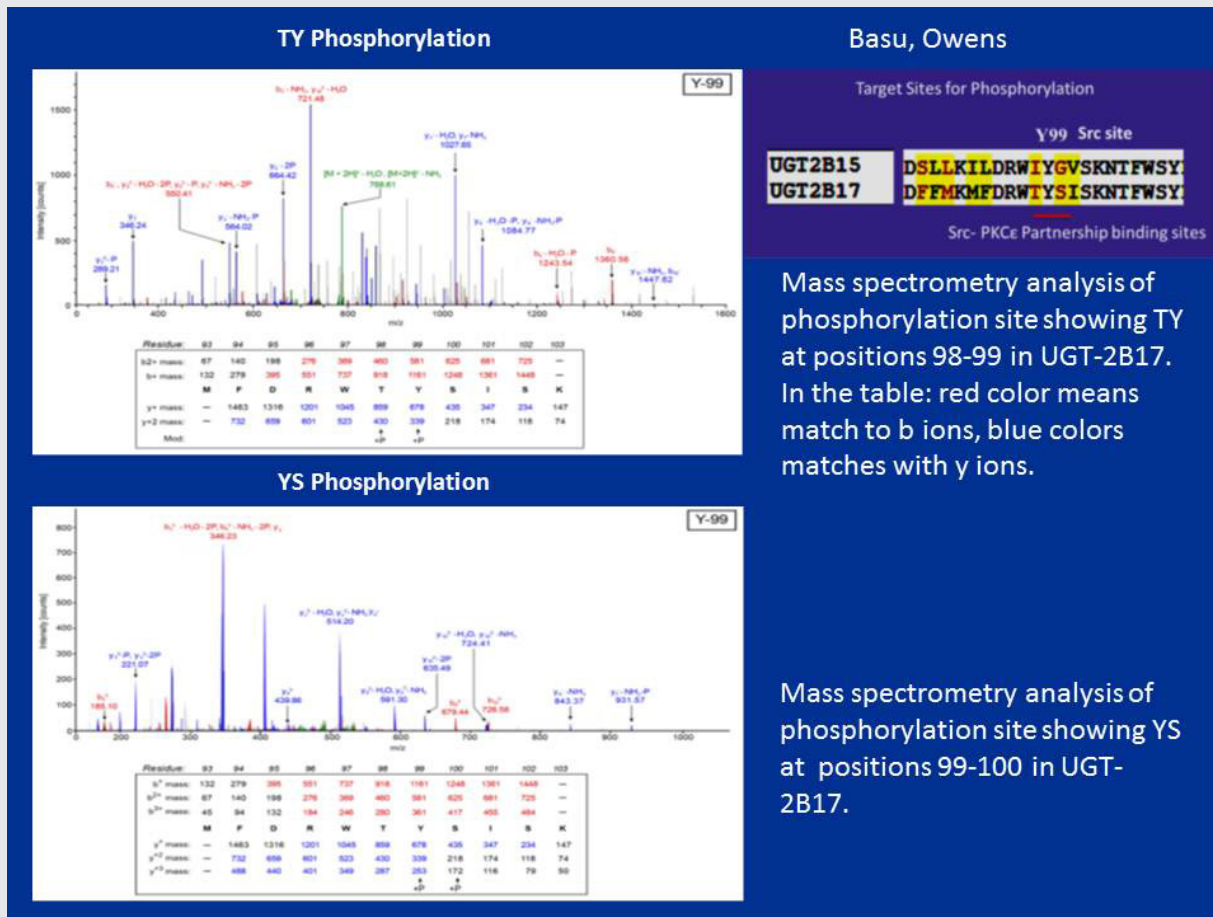
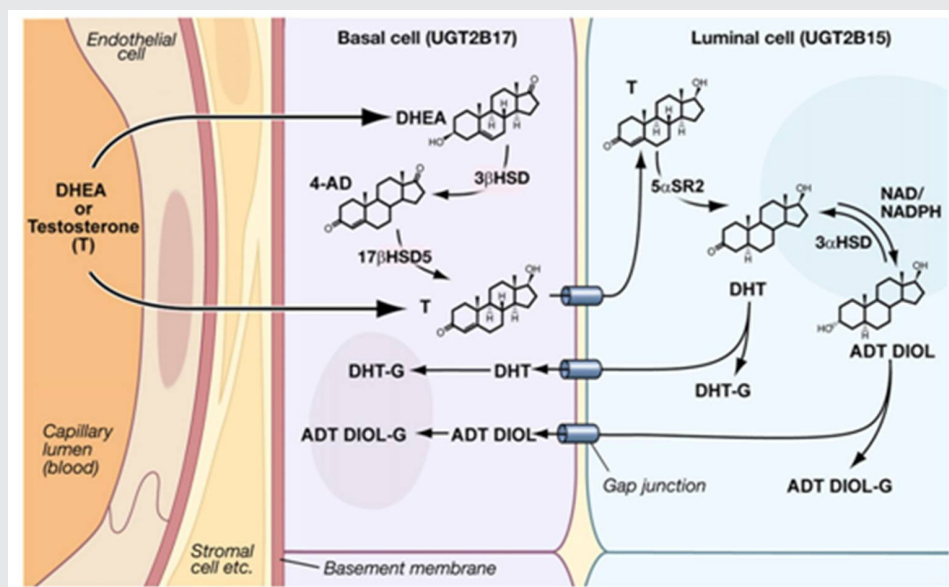

**FIGURE 1.** Mass-spectrometric analysis of TpYpSp phosphorylation of UGT-2B17  
 Phosphorylation of UGT-2B17 at 98–100 (TYS—threonine/tyrosine/serine) residues

constructs in Src-kinase-free cells. The smearing is also consistent with robust signaling surrounding the Src/ PKCε-partnership phosphorylation site. Following UGT-2B17 expression in Src<sup>-/-</sup> compared with Src<sup>+/-</sup> cells, glucuronidation of dihydrotestosterone (DHT) and its 5α-androstane-3α,17β-diol metabolite indicates that Src inhibits the glucuronidation by around 50%, which necessarily concomitantly elevates anti-apoptotic DHT levels. Following the exchange of isoleucine/tyrosine/glycine (IYG) in wild-type (wt) UGT-2B15(IYG) and TYS in wt UGT-2B17(TYS) at their comparable positions of 98 through 100 and subsequent transfection into COS-1 cells, UGT-2B17(IYG) generated 10-fold greater activation *in cellulo* of caspases 8/3 than did wt UGT-2B15, while mutant UGT-2B15(TYS) suppressed activation of caspases 8/3 more than 50% compared with UGT-2B15 levels. The evidence thus indicates that the triple-phosphorylated TpYpSp site on UGT-2B17 creates a signaling site involving Src and PKCε that is anti-apoptotic, while the Src-specific binding/phosphorylation site at position 98–100 in UGT-2B15 is pro-apoptotic. Finally, the evidence indicates that serine 172 is phosphorylated to carry out signaling-mediated catalysis, as shown for some 7 out of 19 other human UGTs.

**FIGURE 2. Predicted small-molecule movements and enzymatic reactions in prostate epithelial cells**

Distribution of normal prostate steroidogenic and UGT isozymes as presented in our publication, S. K. Chakraborty et al., *J Biol Chem* 2012;287:24387. Based on studies cited, prostate DHT synthesis and its metabolism are summarized in the schematic. The EM shows 1:1 stratification of human prostate basal/luminal cells with intervening gap junctional structures that likely allow movement of small molecules between the two cells.



Whereas prostate biochemists discovered that, by occupying the androgen receptor, DHT plays a vital role in supporting the synthesis of the more than 200 secretory proteins necessary for sperm transport fluid, we established that the critically important UGT-2B15 is required for the luminal-cell conversion of DHT to a water-soluble DHT-glucuronide and for the overall maintenance of the luminal cell. More recently, prostate biochemists established that basal cell-distributed UGT-2B17 metabolizes DHT at 10 to 20-fold higher rates than does UGT-2B15. While the exact role of UGT-2B17 in the prostate basal cell remains unknown, studies indicate that the isozyme functions primarily in a supporting role to 'house' intermediate stem cells that contain both cytokeratin cell-surface markers for both luminal and basal cells in a 'Basal Cell Compartment.' Thus, the robust activity of UGT-2B17 is thought to play a role in protecting both newly generated luminal and basal cells for prostate continuity.

While the human prostate luminal cell-distributed UGT-2B15 supports regulated phosphorylation for two different functions, at least one phosphate per UGT-2B15 isozyme undergoes ongoing phosphate signaling at a non-fixed active site, which enables catalysis of an unspecified number of substrates, according to 6 of the 19 human UGTs examined.

## Prostate-distributed mouse Ugt2b34 and Ugt2b36 control estrogenic metabolites.

To establish an *in vivo* mammary-gland model that prevents depuration by 4-OH-catecholestrogens associated with the initiation of carcinogenesis, we pursued studies to identify mouse homologs of the highly effective human UGT-2B7. Using sequence analysis, we found that mouse Ugt-2b34 and Ugt-2b36 homologs avidly metabolize the test agent 4-hydroxyestrone, with Ugt-2b35 expressing trivial activity. Unlike low- $K_m$  UGT-2B7 (14M), Ugt-2b34 and Ugt-2b36 respectively metabolized 4-hydroxyestrone with 90M  $K_m$  and

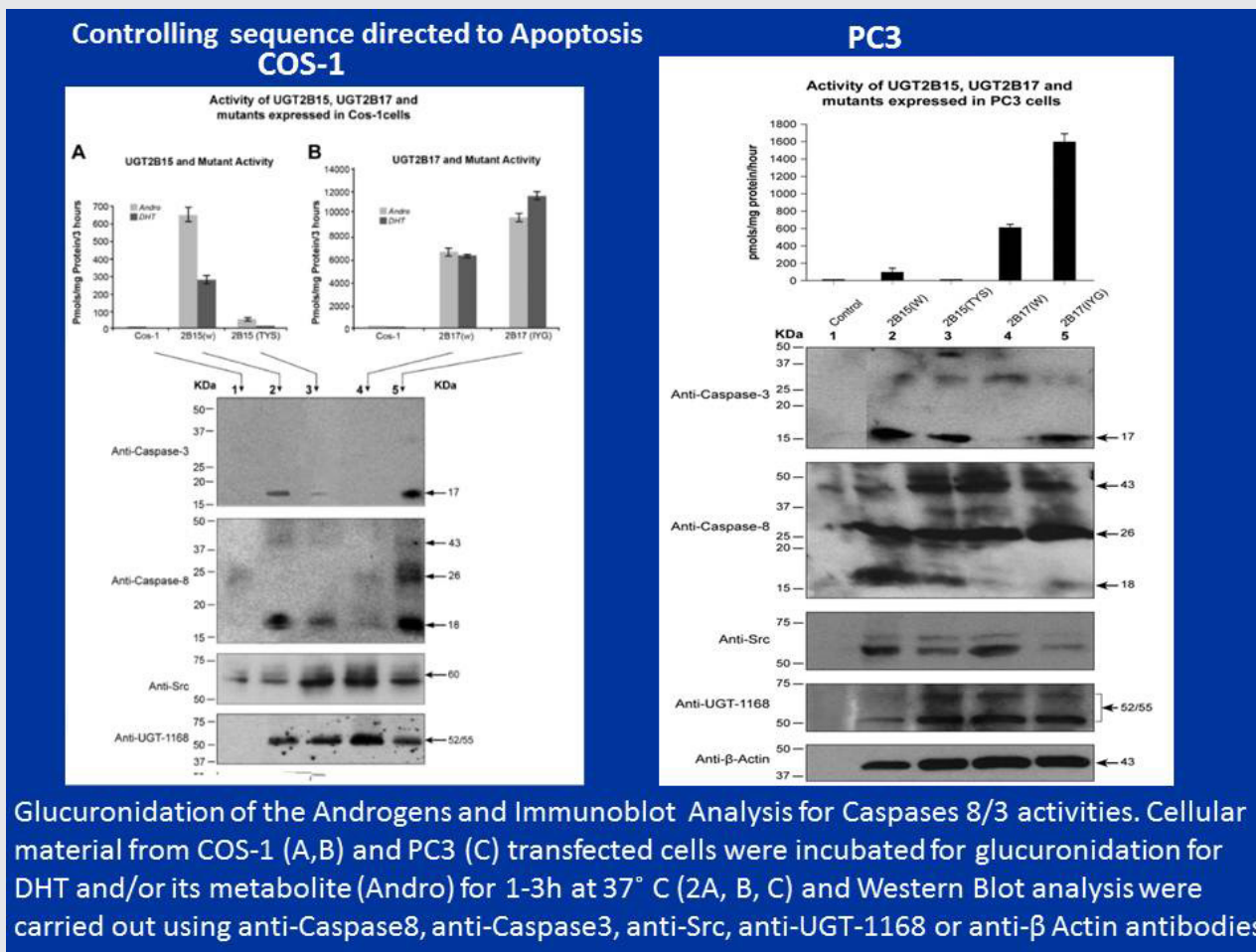

FIGURE 3. Controlling sequences for apoptosis

Controlling sequences for pro-apoptosis and anti-apoptosis in UGT-2B15 and UGT-2B17 expressed in COS-1 cells and the aggressive PC3 prostate cell line

430M  $K_m$ . Unexpectedly, the mouse isozymes are distributed primarily in male hormone-responsive tissues, whereas human UGT-2B7 is found primarily in female hormone-responsive tissues. Also, we found that Ugt-2b34 metabolizes the non-classical estrogenic DHT metabolite ADT-diol at a greater rate than DHT, which is not known to be estrogenic. Notably, UGT-2B7 does not metabolize xeno-estrogens; Ugt-2b34 and Ugt-2b36 did, however, metabolize bisphenol A (BPA) and diethylstilbestrol (DES) at superior rates. We also found, through real-time PCR-based analysis of estrogen receptor alpha (*Esr1*) gene knockout in mouse prostate, 50% and 63% lower Ugt2b34 mRNA and Ugt2b36 mRNA levels, respectively, than in controls. However, estrogen receptor beta (*Esr2*) knockout (KO) revealed a 2.7/3.3-fold increase in Ugt-2b34 mRNA and Ugt-2b36 mRNA, respectively, in the prostate. *Esr1* KO completely suppressed Ugt-2b34 and Ugt-2b36 mammary-gland mRNA; *Esr2* KO caused a 12-fold increase in Ugt-2b34 mRNA without affecting Ugt-2b36 mRNA. Hence, according to tissue-distribution studies, it appears that male mice benefit from both Ugt isoforms, while females benefit from only one Ugt. Our findings for Ugt-2b34 and Ugt-2b36 suggest that the two mouse



### Normal Prostate Epithelial and associated cells with UGT2B15, UGT2B17 and Cell-Surface Markers

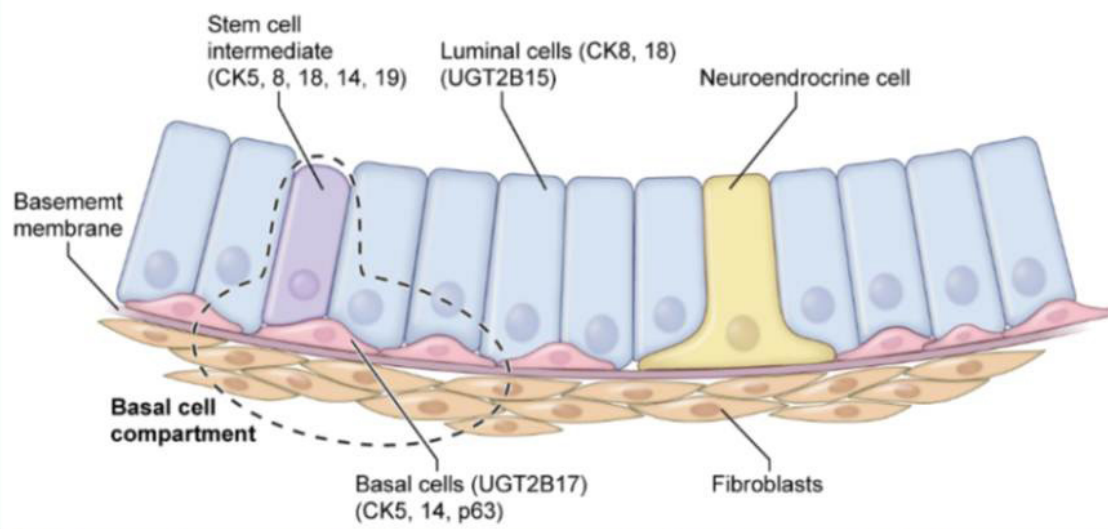

Diagrammatic representation of normal prostate epithelial and associated cells. Representations of normal human prostate luminal and basal epithelial cells surrounded by primary and intermediate-stem, neuroendocrine, normal fibroblast cells and separated by the basement membrane. A fraction of the progenitor intermediate stem cell population contains cytokeratin cell-surface markers for both (luminal) and basal [(CK8 + Ck18) + CK 5+ CK 14+ P63 ] cells, respectively. Authors of these studies suggest this is evidence the two distinct prostate epithelial cells derive from a single stem cell that ultimately gives rise to two distinct differentiated epithelial cells.

Basu, Owens

FIGURE 4. Diagrammatic representation of normal prostate epithelial and associated cells

Normal prostate epithelial and associated cells with UGT-2B15, UGT-2B17, and cell-surface markers.

isozymes are intrinsically programmed to protect against a more complex environment than are human high-activity UGT-2B7 and low-activity UGT-2B4 isozymes (Raychoudhuri A *et al. Biosci Rep*;in press).

## Publications

1. Basu NK, Kole L, Basu M, Chakraborty K, Mitra PS, Owens IS. The major chemical detoxifying system of UDP-glucuronosyltransferases requires regulated phosphorylation supported by protein kinase C. *J Biol Chem* 2008 283:23048-23061.
2. Banerjee R, Pennington MW, Garza A, Owens IS. Mapping the UDP glucuronic acid binding site in UDP-glucuronosyltransferase-1A10 by homology-based modeling: confirmation with biochemical evidence. *Biochemistry* 2008 47:7385-7392.
3. Mitra PS, Basu NK, Owens IS. Src supports UDP-glucuronosyltransferase-2B7 detoxification of catechol

- estrogens associated with breast cancer. *Biochem Biophys Res Commun* 2009 382:651-656.
- Mitra PS, Basu NK, Basu M, Chakraborty S, Saha T, Owens IS. Regulated phosphorylation of a major UDP-glucuronosyltransferase isozyme by tyrosine kinases dictates endogenous substrate selection for detoxification. *J Biol Chem* 2011 286:1639-1648.
  - Chakraborty SK, Basu NK, Jana S, Basu M, Raychoudhuri A, Owens IS. Protein kinase Calpha and Src kinase support human prostate-distributed dihydrotestosterone-metabolizing UDP-glucuronosyltransferase 2B15 activity. *J Biol Chem* 2012 287:24387-24396.

## Collaborators

- Praveen Arany, BDS, MDS, MMSc, PhD, *Oral and Pharyngeal Cancer Branch, NIDCR, Bethesda, MD*
- James L. Gulley, MD, PhD, FACP, *Genitourinary Malignancies Branch, Center for Cancer Research, NCI, Bethesda, MD*
- Antony McDonagh, PhD, *University of California San Francisco, San Francisco, CA*
- Zhihong Nie, PhD, *Maryland Nanocenter, University of Maryland, College Park, MD*
- Juan Rivera, PhD, *Molecular Immunology and Inflammation Branch, NIAMS, Bethesda, MD*

## Contact

For more information, email [owens@helix.nih.gov](mailto:owens@helix.nih.gov).

## Gene Regulation in Innate Immunity

Macrophages and related cells recognize incoming pathogens and produce cytokines, such as interferons (IFNs) and IL-1/IL-6/TNF-alpha. While IFNs impart anti-viral and anti-microbial protection to the host, the latter cytokines are associated with inflammatory responses. IFNs are produced upon activation of the IRF (interferon regulatory factor) family of transcription factors, while inflammatory cytokines are produced by the activation of the transcription factor NFkB. Our goal is to study the molecular pathways that direct the development and function of macrophages and other myeloid cells. To this end, we focus on the role of IRF8 in innate immunity. IRF8, a member of the IRF family, is expressed in macrophages, dendritic cells (DCs), and microglia at high levels, and is required for the production of both type I and type II IFNs. IRF8 is essential for mounting the first line of defense against various invading pathogens prior to the initiation of antigen-specific adaptive immune responses.

Transcriptionally active genes are embedded in chromatin that is dynamically exchanged, whereas silenced genes are surrounded by more stable chromatin. The chromatin environment contributes to the epigenetic states of given cells and influences transcriptional processes. We have long been working on BRD4, a bromodomain protein that binds to acetylated histones and promotes active transcription. BRD4 is involved in the dynamic chromatin exchange that takes place in highly transcribed genes. The exchange requires a special histone called H3.3. As a result of the association with transcription, H3.3 is implicated in epigenetic control of gene expression patterns. Our goal is to elucidate the activity of BRD4 and histone H3.3 in innate immunity.

### IRF8 is a master regulator of autophagy in macrophages and restricts *Listeria monocytogenes* replication.

Autophagy is a highly conserved catabolic process to degrade misfolded self-proteins and damaged organelles. Autophagy is essential for embryonic development and occurs in a wide variety of adult cells. Macrophages and DCs use this mechanism to fortify their ability to eliminate invading pathogens. Autophagy plays a critical role in innate resistance to various bacteria, including *Mycobacterium*



**Keiko Ozato, PhD, Head, Section on Molecular Genetics of Immunity**

Anup Dey, PhD, *Biologist*

Tiyun Wu, PhD, *Staff Scientist*

Mahesh Bachu, PhD, *Visiting Fellow*

Chao Chen, PhD, *Visiting Fellow*

Vishal Nehru, PhD, *Visiting Fellow*

Ryota Oda, PhD, *Visiting Fellow*

Sumihito Togi, PhD, *Visiting Fellow*

Keith Sakata, BS,

*Postbaccalaureate Intramural Research Training Award Fellow*

**FIGURE 1. IRF8 is a master regulator of autophagy in macrophages.**

Left: Wild-type (WT) and *Irf8*<sup>-/-</sup> macrophages were infected with *Listeria monocytogenes* for 3 days, and localization of the *Listeria* antigens (red) and activated autophagy component LC3 (green) was examined by immunostaining. Blue color represents DNA (nucleus) by DAPI stain. *Irf8*<sup>-/-</sup> cells had fewer LC3 punctae and contained many more *Listeria* than wild-type cells.

Right: *Listeria* replication was tested by the colony-forming unit (cfu) assay. Data show that the bacteria grew exponentially in *Irf8*<sup>-/-</sup> macrophages, while bacterial growth was restricted in their wild-type counterparts.

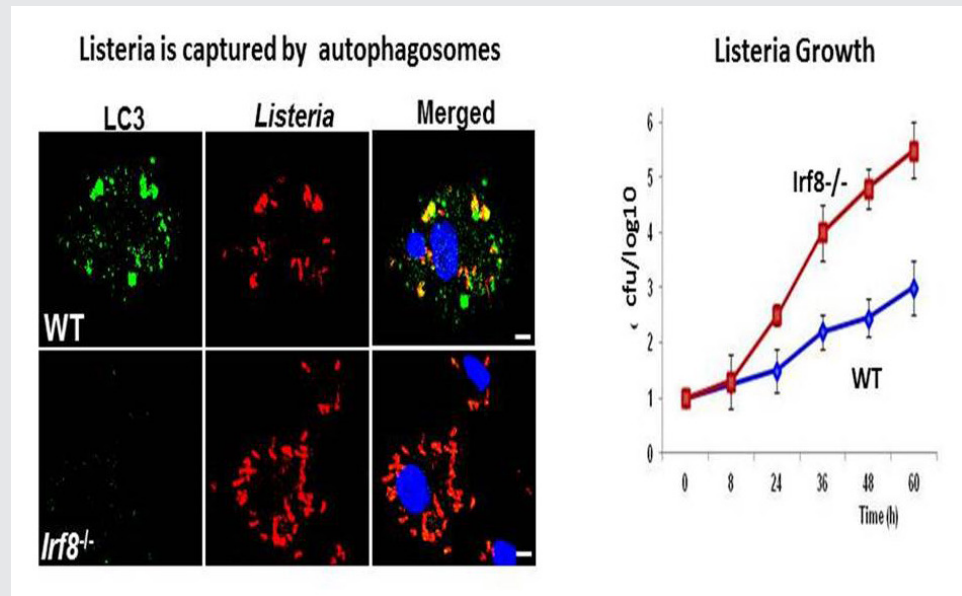

*tuberculosis* and *Salmonella*. Autophagy is activated by many stresses, including IFN-gamma-toll like receptor stimulation and bacterial infection. In addition, starvation and macrophage colony-stimulating factor (M-CSF) stimulation trigger autophagy in macrophages. Our initial gene profiling analysis in DCs pointed to the role of IRF8 in autophagy gene activation. Subsequent analysis confirmed that 17 autophagy genes are downregulated in *Irf8*<sup>-/-</sup> macrophages. The IRF8-regulated autophagy genes include those active at all steps of autophagy, from early signaling, autophagosome formation, lysosomal fusion, and degradation of captured materials. Using the ChIP-PCR technique, we confirmed that IRF8 binds to the upstream elements of many autophagy genes. Interestingly IRF8 was upregulated following all stresses mentioned above. As a result, *Irf8*<sup>-/-</sup> macrophages were defective in autophagic activity and accumulated the ubiquitin-binding protein SQSTM1 in the cytoplasm, forming harmful aggregates. We further showed that *Irf8*<sup>-/-</sup> macrophages were highly susceptible to *Listeria monocytogenes* infection. When infected with *Listeria*, many autophagy genes in wild-type macrophages were transcriptionally activated, leading to autophagic capturing and degradation of the bacteria. In contrast, these processes were absent from *Irf8*<sup>-/-</sup> macrophages, leading to uncontrolled bacterial growth (Figure 1). Thus IRF8 serves as a master regulator of autophagy in macrophages and promotes innate resistance to infection and macrophage survival.

We also investigated innate resistance to Ebola virus (EBOV) infection and found IRF8-dependent type I IFN signaling to be important. EBOV causes a severe hemorrhagic disease with high fatality. In collaboration with scientists at the United States Army Medical Research Institute, we showed that virus-like particles (VLPs) from EBOV stimulate toll-like receptor (TLR) signaling and then the IFN (JAK-STAT) pathway *in vitro*. We then showed that VLPs protect mice from lethal EBOV infection when given before and after EBOV infection. However, *Ifnar* knockout (KO) mice died even after VLP treatment, while wild-type mice were fully protected. VLPs caused accelerated induction of interferon-stimulated genes (ISGs) in wild-type but not in *Ifnar* KO mice, a likely mechanism of protection. Moreover, VLP protection required IRF8, which boosted IFN feedback signaling.

## Epigenetic states of the IRF8 locus in human cells

IRF8 binds to two motifs in macrophages and developing myeloid cells. In collaboration with others, we studied the genome-wide distribution of IRF8. The studies highlighted two widely distributed DNA motifs to which IRF8 bound: ETS/IRF composite motif (GGAA and GAAA and similar) and the ISRE-like motif, the GAAA repeat. For example, IRF8 bound to a distal enhancer of the *Klf4* gene, through which it promoted myeloid cell differentiation. We found that IRF8 binding is enriched with the composite sites in developing monocytes while IRF8 binding to ISRE-like sites rose upon stimulation in bone marrow (BM) macrophages. The studies serve as a steppingstone for our future work to analyze chromatin environment important for macrophage innate immunity. To assess epigenetic features of the IRF family genes, we mined publicly available data on the post-translational histone modification marks reported in various human cells, which are deposited in the ENCODE (Encyclopedia of DNA Elements) repository at the University of California Santa Cruz (<https://genome.ucsc.edu/ENCODE>). We found that IRF family genes can be classified into several distinct groups according to the pattern of histone modifications. Acetylation of H3 and H4 and methylation of H3 at K4, K9, and K27 were major features assisting our classification (Figure 2). Interestingly, these chromatin features matched their functional properties and expression patterns. The analysis strengthened the notion that chromatin regulators are unrecognized players in IRF-family activity.

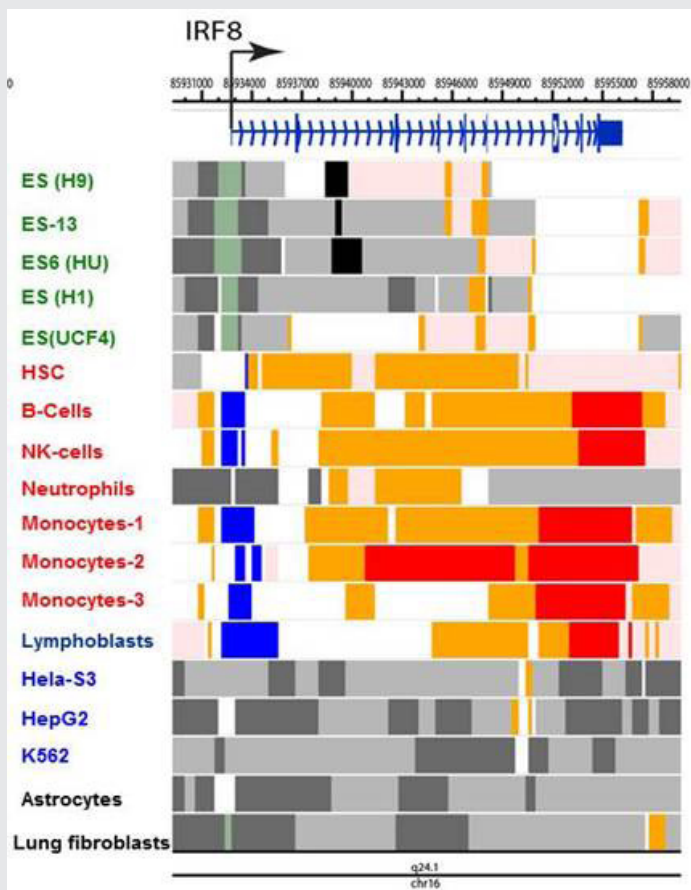

**FIGURE 2. Epigenetic states of the IRF8 locus in human cells**

Epigenome landscape of hIRF8 gene in ES (*gray*), *ex vivo* immune cells (*red*) and cell lines (*black*). Data were obtained from the ENCODE program and reorganized to visualize indicated chromatin states, using the Washington University Epigenome Browser (<http://epigenomegateway.wustl.edu/browser>). Cells examined were embryonic stem (ES) cells (*green*), primary immune cells (*red*), and cancer cell lines (*blue*). Chromatin states were assessed by the indicating modifications: active TSS (H3K3me3, H3K4me2, H3K27Ac, H3K9Ac); bivalent promoter (H3K4me3, H3K27me3); strong promoter (H3K36me3, H4K20me1, H3K79me2); weak or no transcription (H3K36me3, H4K20me1, H3K79me2); enhancer (H3K4me1, H3K27Ac, H3K9Ac); heterochromatin (H3K9me3); polycomb repression (H3K27me3).

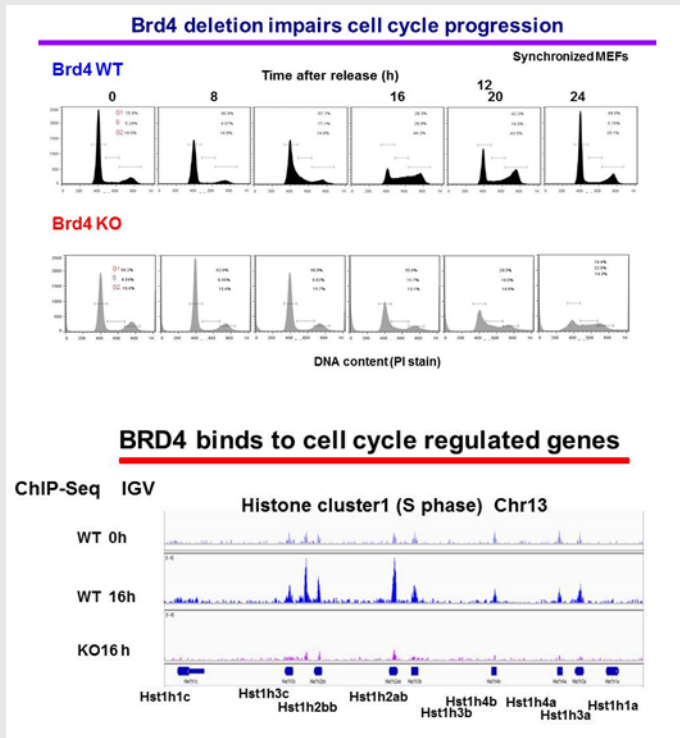

**FIGURE 3. BRD4 is required for cell-cycle progression of normal cells.**

Upper panel: wild-type (WT) and *Brd4*<sup>-/-</sup> (KO) mouse embryonic fibroblasts (MEFs) were synchronized by serum starvation, and cell-cycle progression was examined after release. Propidium iodide staining shows percentages of cells in G1, S, G2/M.

Lower panel: BRD4 binding was tested by ChIP-seq analysis of synchronized WT and *Brd4* KO cells. The figure depicts BRD4 occupancy at the histone H1 locus.

## BRD4 supports elongation of the eRNA and the coding RNA.

BRD4 has two bromodomains through which it binds to the acetylated histones H3 and H4. BRD4 also interacts with P-TEFb, the elongation factor composed of Cyclin T and CDK9. The interaction relieves the 5'-paused RNA polymerase II (Pol II) to trigger elongation. Recent studies from various laboratories showed that BRD4 promotes cancer cell growth, including several forms of leukemia, primarily by promoting *c-Myc* expression. Interestingly, pharmacological inhibitors for bromodomains in BET (bromodomain and extra-terminal) proteins are found to be effective anti-leukemia drugs in animal models. To further study the extent of BRD4 involvement in elongation, we performed RNA-seq and ChIP-seq analyses of chromatin-bound RNA in quiescent and serum-stimulated fibroblasts. We were particularly interested in the enhancer regions that carry epigenetic histone marks, such as H3K4me1 and H3K27ac, thereby affecting expression of the coding genes. We showed that serum stimulation activates transcription of many cell growth-regulated genes in their coding region as well as the enhancer (e) sequences present either in upstream or downstream. Transcription of both coding and eRNAs were dependent on BRD4's interaction with acetylated histones, given that JQ1, a BRD4 small molecule inhibitor, blocked both RNAs. In addition, ChIP-seq data showed that BRD4 localized to the coding and enhancer regions overlapping with the localization of Pol II, supporting the view that BRD4 takes part in the elongation processes by virtue of its ability to bind to acetylated histones. To confirm the broad role of BRD4 in RNA transcription, we labeled nascent RNA with Br-UTP and immunoprecipitated it with BRD4 antibody and then with BrdU antibody. Double immunoprecipitated RNA samples were analyzed by deep sequencing. We found that BRD4 is bound to newly synthesized eRNAs as well as to coding RNAs. We suggest a model wherein BRD4 directs elongation of eRNA and coding RNA (mRNA). The process is guided by the distribution of acetylated histones, highlighting an epigenetic component of transcription.

## Analysis of *Brd4* conditional knockout mice: BRD4 promotes proliferation by regulating many cell-cycle genes.

BRD4 is a bromodomain protein of the BET family that binds to acetylated histones. It is expressed at high levels in most, if not all cells. BRD4 is necessary for very early embryonic development. Thus conventional *Brd4* knockout mice are embryonic lethal. We previously showed that BRD4 recruits P-TEFb and promotes transcription of cellular and viral genes. Recent reports found that BRD4 also has a critical role in forming super-enhancers. Super-enhancers are long stretches of regulatory DNAs densely occupied by transcription factors and chromatin regulators. They direct very strong transcription of select genes, thus helping define cell and lineage identity. The development of small molecule inhibitors that inhibit binding of acetyl-histones to the BET family proteins has had a dramatic effect on research on BRD4. The inhibitors, mostly by acting on BRD4 among other BET proteins, antagonize cancer growth, particularly leukemia and lymphoma, and inhibit inflammatory responses relevant to cardiovascular and autoimmune diseases. The findings implicate BRD4 for disease promotion but offer new therapeutic possibilities for a number of difficult-to-treat diseases. However, because of inherent limitations of pharmacological approaches, the precise role of BRD4 in healthy and diseased conditions remains uncertain. For example, the impact of BET inhibitors on normal cells is not well understood (such as on hematopoietic stem cells when treating leukemia/lymphoma), nor is it known how BET inhibitors affect anti-microbial activity of macrophages when used for treatment of inflammatory diseases. It is thus critical to gain full understanding of BRD4 activity in normal hematopoiesis and during innate and adaptive immunity.

Our approach is to investigate the role of BRD4 and its mechanism of action by studying *Brd4* conditional knockout mice, rather than through the use of inhibitors. Currently, we are investigating the role of BRD4 in cell-cycle progression using mouse embryonic fibroblasts (MEFs) from *Brd4<sup>fl/fl</sup>xER<sup>T2</sup>-Cre*. In these cells, the *Brd4* gene can be deleted in a Tamoxifen-inducible manner. Flow cytometry analysis of synchronized cells showed that cell-cycle progression is severely defective in *Brd4<sup>-/-</sup>* MEFs, in that G1/S transition and progression to G2/M are both delayed or blocked in a substantial fraction of cells (Figure 3, upper panel). The data indicate that BRD4 regulates cell growth at several stages by a complex, multi-faceted mechanism, beyond the regulation of c-Myc at G1, as proposed for cancer cells. Our RNA-seq data obtained from G0, G1, S, and G2/M stages substantiated this notion and showed that cell-cycle genes active at different stages are broadly downregulated in *Brd4<sup>-/-</sup>* cells. We surmise that BRD4 directly binds to many of these genes and drives their transcription independently. The view is supported by ChIP-seq analysis of genome-wide BRD4 binding at different stages of cell cycle, as BRD4 was found to occupy cell-cycle genes in a time-dependent manner. An IGV (Integrative Genomics Viewer) example in shows that BRD4 is absent from the histone H1 loci in G0, but occupies the loci 16 h after release (S phase) in wild-type cells, but not in *Brd4<sup>-/-</sup>* cells (KO) (Figure 3, lower panel). To eliminate false (phantom) peaks, ChIP-seq of *Brd4<sup>-/-</sup>* cells authenticates the BRD4 peaks. To further study BRD4 activity at multiple cell-cycle stages, particularly at G2/M, we plan to focus on several G2/M genes to delineate the role of BRD4 in maintaining genome integrity.

## Publications

1. Ayithan N, Bradfute S B, Anthony SM, Stuthman KS, Bavari S, Bray M, and Ozato, K. Virus-like particles activate type I interferon pathways to facilitate post-exposure protection against Ebola virus infection. *PLoS One* 2015 10:e0118345.
2. Gupta M, Shin DM, Ramakrishna L, Goussetis DJ, Plataniias LC, Xiong H, Morse HC 3rd, Ozato K. IRF8

directs stress-induced autophagy in macrophages and promotes clearance of *Listeria monocytogenes*. *Nat Commun* 2015 6:6379.

3. Devaiah BN, Case-Borden C, Gekonne A, Hsu CH, Chen Q, Meerzaman D, Dey A, Ozato K, Singer DS. BRD4 is a histone acetyltransferase that evicts nucleosomes from chromatin. *Nat Struct Mol Biol* 2016 23:540-548.
4. Chang TH, Yoshimi R, Ozato K. Tripartite Motif (TRIM) 12c, a mouse homolog of TRIM5, is a ubiquitin ligase that stimulates Type I IFN and NF- $\kappa$ B pathways along with TNFR-associated Factor 6. *J Immunol* 2015 195:5367-5379.
5. Bachu M, Dey A, Ozato K. Chromatin landscape of the IRF genes and role of the epigenetic reader BRD4. *J Interferon Cytokine Res* 2016 36:470-475.

## Collaborators

- Steven Holland, MD, *Laboratory of Clinical Infectious Diseases, NIAID, Bethesda, MD*
- Herbert Morse II, MD, *Laboratory of Immunopathology, NIAID, Rockville, MD*
- Dinah S. Singer, PhD, *Experimental Immunology Branch, NCI, Bethesda, MD*
- Tomohiko Tamura, MD, PhD, *Tokyo University, Tokyo, Japan*
- Jun Zhu, PhD, *DNA Sequencing and Genomics Core, NHLBI, Bethesda, MD*

## Contact

For more information, email [ozatok@mail.nih.gov](mailto:ozatok@mail.nih.gov) or visit <http://ozatolab.nichd.nih.gov>.



## Diagnosis, Localization, Pathophysiology, and Molecular Biology of Pheochromocytoma and Paraganglioma

We conduct patient-oriented research into the etiology, pathophysiology, genetics, diagnosis, localization, and treatment of pheochromocytoma (PHEO) and paraganglioma (PGL). Projects include both translational research—applying basic science knowledge to clinical diagnosis, pathophysiology, and treatment—and ‘reverse translation research,’ by which clinical findings lead to new concepts for pursuit by basic researchers in the laboratory. Our goals are to (1) establish new and improved methods and strategies for novel diagnostic and localization approaches to PHEO/PGL; (2) explain the molecular and cellular basis for varying clinical presentations of PHEOs/PGLs and establish the pathways of tumorigenesis; (3) search for new molecular and genetic/epigenetic markers for diagnosis and treatment of metastatic PHEO/PGL; (4) introduce new therapeutic options for malignant/metastatic PHEO/PGL; and (5) facilitate new and improved collaborations and interdisciplinary studies. To achieve these goals, we enter into multidisciplinary collaborations with investigators from several NIH Institutes and outside medical centers. We link a patient-oriented component with two bench-level components. The patient-oriented component (medical neuroendocrinology) is the driving force for our hypotheses and discoveries. The two bench-level components (tumor pathogenesis/genetics and chemistry; biomarkers) emphasize, first, technologies of basic research tailored for pathway and target discovery and, second, the further development of discoveries into clinical applications.

### Clinical aspects of pheochromocytoma and paraganglioma

Overall, about 10 to 20% of PHEOs/PGLs (also collectively known as PPGLs), are metastatic, with higher metastatic potential observed in succinate dehydrogenase subunit B/fumarate hydratase (SDHB/FH)-related tumors. Owing to the improved availability of biochemical and genetic testing and the frequent use of anatomical/functional imaging, there is currently an improved detection rate of metastatic PPGL. We conducted a retrospective analysis of 132 patients (27 children, 105 adults) with metastatic PPGL, diagnosed and treated from 2000 to 2014. Seventy-seven (58%) males and 55 (42%) females were included; 39 (30%) have died, with no sex preference. Seventy-three



**Karel Pacak, MD, PhD, DSc,**  
*Head, Section on Medical  
Neuroendocrinology*

Thanh-Truc Huynh, MS, *Biologist*

Karen T. Adams, MSc, CRNP,  
*Research Nurse*

Ingo Janssen, MD, *Postdoctoral  
Visiting Fellow*

Petra Bullova, MS, *Predocctoral  
Visiting Fellow*

Ivana Jochmanova, MD,  
*Predocctoral Visiting Fellow*

Roland Darr, MD, *Volunteer*

Garima Gupta, MD, *Volunteer*

Veronika Caisova, MS, *Predocctoral  
Visiting Fellow*

Katherine Wolf, BS,  
*Postbaccalaureate Fellow*

Bruna Viana, BS, *Postbaccalaureate  
Fellow*

Ying Pang, MD, PHD, *Postdoctoral  
Visiting Fellow*

Jean Caringal, MD, *Volunteer*

Amy Lopez, MD, *Volunteer*

Valerie Valdez, MD, *Volunteer*

Erick Mendoza, MD, *Volunteer*

Julie Zemskova, MS, *Summer  
student*

Gabriel Schneider, *Summer student*

Tamara Prodanov, MD, *Clinical  
Trial Database (CTDB) coordinator*

(55%) patients had SDHB mutations; 59 (45%) patients had apparently sporadic tumors (AST). The average age of SDHB patients at primary tumor diagnosis ( $31 \pm 16$  years) was significantly lower than AST patients ( $40 \pm 15$  years). The average metastatic interval (MI) declined significantly with increasing age in both SDHB and AST patients. Only 16% of all primary tumors were smaller than 4.5 cm. Eleven percent of patients had biochemically silent disease, more with SDHB. Of SDHB patients, 23% had metastatic tumors at first diagnosis, compared with 15% of AST patients. Five- and 10-year survival rates were significantly better for metastatic AST than for SDHB patients. Overall, survival was significantly longer in children than in adults, especially in SDHB patients. The deceased patients all died from PPGL, whose phenotypes were mainly noradrenergic. We concluded, that, in children, metastatic PPGLs are mainly the result of SDHB mutations; in adults they are equally distributed between in SDHB mutations and AST, with better 5- and 10-year survival rates for ASTs. Among SDHB patients, children survive longer than adults. Primary metastatic tumors, mostly presenting as noradrenergic PGLs, are larger than 4.5 cm in more than 80% of patients. The frequency of metastatic tumors from primary AST increases with age, including a lower MI compared with SDHB tumors.

Pharmacological treatment is mandatory in patients with hormonally functional PPGL. We evaluated whether patients initially diagnosed with hormonally functional PPGL by various medical subspecialties received proper adrenoceptor blockade, and we analyzed factors predicting the prescription of adequate treatment. In a retrospective cohort study, we reviewed data of 381 patients from Cedars-Sinai Medical Center and others outside the National Institutes of Health initially diagnosed with hormonally functional PPGL, who were referred to these institutions between January 2001 and April 2015. We used logistic regression to assess factors associated with proper adrenoceptor blockade. Adequate pharmacological treatment was prescribed to 69.3%, of which 93.1% received  $\alpha$ -adrenoceptor blockers. Regarding patients who were inappropriately treated, 53% did not receive any medication. Independent predictors of the prescription of a proper blockade were the diagnosis by endocrinologists, the presence of high blood pressure, and evidence of metastasis. We concluded that, although the majority of patients received adequate pharmacological treatment, almost one-third were either not treated or received inappropriate medications. The diagnosis by endocrinologists, the presence of high blood pressure, and the evidence of metastatic disease were identified as independent predictors of a proper blockade. The results highlight the need to educate physicians about the importance of starting adequate adrenoceptor blockade in all patients with hormonally functional PPGL.

## Hereditary pheochromocytoma and paraganglioma

The syndrome of PGL, somatostatinoma (SOM), and early childhood polycythemia in patients with somatic mutations in the hypoxia-inducible factor 2 alpha (*HIF2A*) gene has been described in only a few patients worldwide. The study provided detailed information about the clinical aspects and course of seven patients with this syndrome and brought these experiences into perspective with the pertinent literature. Six females and one male presented at a median age of 28 years (range 11–46). Two were found to have *HIF2A* somatic mosaicism. No relatives were affected. All patients were diagnosed with secondary polycythemia before age 8 and before PGL/SOM developed. PGLs were found at a median age of 17 years (range 8–38) and SOMs at 29 years (range 22–38). PGLs were multiple, recurrent, and metastatic in 100%, 100%, and 29% of all cases, and SOMs in 40%, 40%, and 60%, respectively. All PGLs were primarily norepinephrine-producing. All patients had abnormal ophthalmologic findings and those with SOMs had gallbladder disease. Computed tomography (CT) and magnetic resonance imaging (MRI) revealed cystic lesions at several sites and hemangiomas in four patients (57%), previously thought to be pathognomonic for von Hippel-Lindau

disease. The most accurate radiopharmaceutical to detect hereditary PGL associated with polycythemia appeared to be [<sup>18</sup>F]-fluorodihydroxyphenylalanine ([<sup>18</sup>F]-FDOPA). Therefore, [<sup>18</sup>F]-FDOPA PET/CT, but not [<sup>68</sup>Ga]-(DOTA)-[Tyr3]-octreotate ([<sup>68</sup>Ga]-DOTATATE) PET/CT, is recommended for tumor localization and aftercare in this syndrome. The long-term prognosis of the syndrome is unknown. However, to date no deaths occurred after six years follow-up. Physicians should be aware of this unique syndrome and its diagnostic and therapeutic challenges.

Previously, mutations in the *SDHA/SDHB/SDHC/SDHD*, *SDHAF2*, *VHL* (encoding the von Hippel-Lindau tumor suppressor), *FH*, *PHD1*, and *PHD2* genes (encoding hypoxia-inducible factor prolyl hydroxylases 1 and 2, respectively) have been associated with HIF (hypoxia-inducible factor) activation and the development of pseudo-hypoxic (cluster-1) PGLs. To a certain extent, these tumors overlap in terms of tumor location, syndromic presentation, and noradrenergic phenotype. However, they also differ particularly by clinical outcome and by the presence of other tumors or abnormalities. We aimed to establish additional molecular differences between HIF2A and non-HIF2A pseudo-hypoxic PGLs. We compared RNA expression patterns of six HIF2A PGLs from two patients with eight normal adrenal medullas and other hereditary pseudo-hypoxic PGLs (13 *VHL*, 15 *SDHB*, and 14 *SDHD*). Unsupervised hierarchical clustering showed that HIF2A PGLs made up a cluster that was separate from other pseudo-hypoxic PGLs. Significance analysis of microarray yielded 875 differentially expressed genes between HIF2A and other pseudo-hypoxic PGLs after normalization to the adrenal medulla. Prediction analysis of microarray allowed correct classification of all HIF2A samples based on as little as three genes—*TRHDE* (encoding thyrotropin-releasing hormone-degrading enzyme), *LRRC63* (encoding leucine-rich repeat-containing protein 63), and *IGSF10* (encoding immunoglobulin superfamily member 10). We selected genes with the highest expression difference between normal medulla and HIF2A PGLs for confirmatory quantitative reverse transcriptase polymerase chain reaction. In conclusion, HIF2A PGLs show a characteristic expression signature that separates them from non-HIF2A pseudo-hypoxic PGLs. Unexpectedly, the most significantly differentially expressed genes had not been previously described as HIF target genes.

Gangliocytic PGL (GPGL), a mixed neuro-ectodermal–endodermal tumor, is a rare and unique type of PGL that is almost exclusively located in the second portion of the duodenum, much like *HIF2A*-related somatostatinomas. Both GPGLs and *HIF2A*-related somatostatinomas produce and/or secrete somatostatin. In our series of 10 GPGLs, we found that two had *HIF2A* gene mutations.

## Imaging of pheochromocytomas and paragangliomas

Patients with succinate dehydrogenase subunit B (*SDHB*) mutation-related PPGL are at a higher risk for metastatic disease than those with other hereditary PPGLs. Current therapeutic approaches are limited, but the best outcomes are based on the early and proper detection of as many lesions as possible. Because PPGLs overexpress somatostatin receptor 2 (*SSTR2*), the goal of our study was to assess the clinical utility of <sup>68</sup>Ga-DOTATATE positron emission tomography/computed tomography (PET/CT) and to evaluate its diagnostic utility in comparison with the currently recommended functional imaging modalities <sup>18</sup>F-fluorodopamine (<sup>18</sup>F-FDA), <sup>18</sup>F-FDOPA, <sup>18</sup>F-fluoro-2-deoxy-d-glucose (<sup>18</sup>F-FDG) PET/CT as well as CT/MRI. <sup>68</sup>Ga-DOTATATE PET/CT was prospectively performed in 17 patients with *SDHB*-related metastatic PPGLs. All patients also underwent <sup>18</sup>F-FDG PET/CT and CT/MRI, with 16 of the 17 patients also receiving <sup>18</sup>F-FDOPA and <sup>18</sup>F-FDA PET/CT scans. We compared detection rates of metastatic lesions among all these functional imaging studies. A composite synthesis of all used functional and anatomical imaging studies served as the imaging

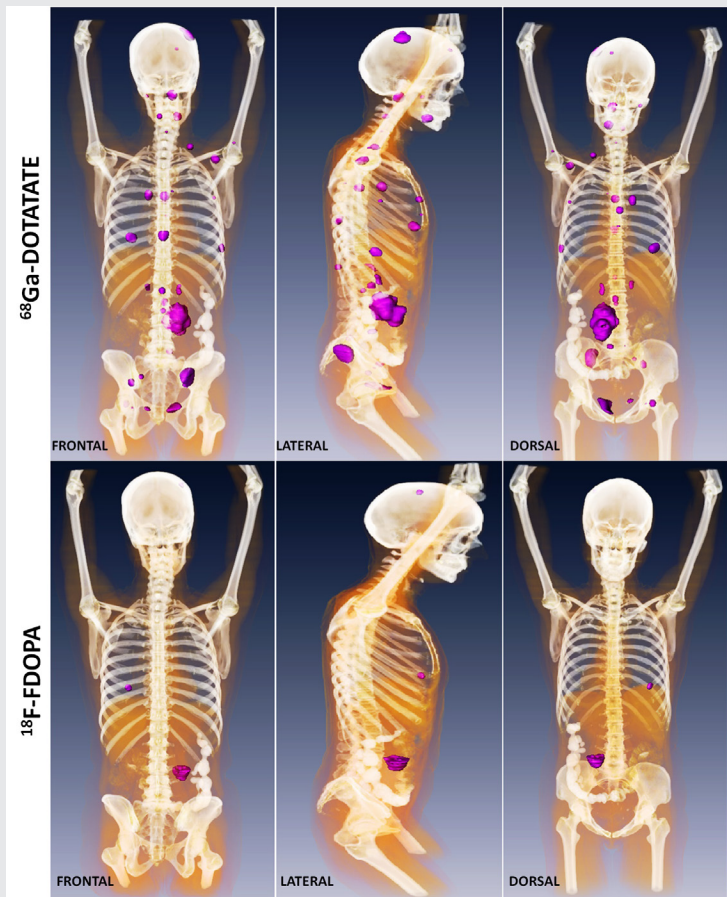

**FIGURE 1. Metastatic paraganglioma detected by  $^{68}\text{Ga}$ -DOTATATE PET/CT and  $^{18}\text{F}$ -FDOPA PET/CT**

Detection of metastatic paraganglioma with the novel imaging modality  $^{68}\text{Ga}$ -DOTATATE PET/CT compared with  $^{18}\text{F}$ -FDOPA PET/CT (frontal, lateral, and dorsal views)

Authors: Papadakis GZ, Bagci U, Millo CM, Janssen I, Patronas NJ, Stratakis CA, Pacak K

comparator.  $^{68}\text{Ga}$ -DOTATATE PET/CT demonstrated a lesion-based detection rate of 96.5–99.5%,  $^{18}\text{F}$ -FDG,  $^{18}\text{F}$ -FDOPA,  $^{18}\text{F}$ -FDA PET/CT, and CT/MRI showed detection rates of 81.3–89.4%, 55.6–66.9%, 46.1–57.7%, and 80.0–88.5%, respectively. We concluded, that  $^{68}\text{Ga}$ -DOTATATE PET/CT gives a detection rate significantly superior to all other functional and anatomical imaging modalities and may represent the preferred future imaging modality for evaluating SDHB-related metastatic PPGL.

Another prospective study included 22 patients (15 men, 7 women; aged  $50.0 \pm 13.9$  years) with confirmed metastatic PPGL, a negative family history for PPGL, and negative genetic testing, who underwent  $^{68}\text{Ga}$ -DOTATATE,  $^{18}\text{F}$ -FDG PET/CT, and CT/MRI. Twelve patients underwent an additional  $^{18}\text{F}$ -FDOPA PET/CT scan and eleven an additional  $^{18}\text{F}$ -FDA PET/CT scan. We compared the rates of detection of metastatic lesions among all the imaging studies. A composite of all functional and anatomical imaging studies served as the imaging comparator.  $^{68}\text{Ga}$ -DOTATATE PET/CT showed a lesion-based detection rate of 95.8–98.7%.  $^{18}\text{F}$ -FDG PET/CT,  $^{18}\text{F}$ -FDOPA PET/CT,  $^{18}\text{F}$ -FDA PET/CT, and CT/MRI showed detection rates of 49.2%, 74.8%, 77.7%, and 81.6%, respectively. The results thus demonstrated the superiority of  $^{68}\text{Ga}$ -DOTATATE PET/CT in the localization of sporadic metastatic PPGLs compared with all other functional and anatomical imaging modalities (Figure 1) and suggest modification of future guidelines towards this new imaging modality. In the last study that included 20 patients with head and neck PGLs, we found that  $^{68}\text{Ga}$ -DOTATATE PET/CT was also superior to other imaging modalities.

## Therapeutic aspects of pheochromocytoma and paraganglioma

Hypoxia is a common feature of solid tumors that activates a plethora of pathways, resulting in proliferation and resistance of cancer cells to radio- and chemotherapy. PPGLs with mutations in *SDHB* are the most aggressive forms of the disease, partly owing to their pseudo-hypoxic character, metabolic abnormalities, and elevated levels of reactive oxygen species (ROS). We investigated the effect of piperlongumine (PL), a natural product with cytotoxic properties towards cancer cells by significantly increasing intracellular ROS levels, on PHEO cells. We reported for the first time that PL mediates PHEO cell death by activating both apoptosis and necroptosis *in vitro* and *in vivo*. The effect is magnified in hypoxic conditions, making PL a promising potential candidate for use as a therapeutic option for patients with PPGL, including those with *SDHB* mutations.

In another study, we evaluated a novel topoisomerase I inhibitor, LMP-400, as a potential treatment for this devastating disease. We found high expression of topoisomerase I in human metastatic PHEO, thus providing a basis for the evaluation of a topoisomerase 1 inhibitor as a therapeutic strategy. LMP-400 inhibited the cell growth of established mouse PHEO cell lines and primary human tumor tissue cultures. In a study performed in athymic female mice, LMP-400 demonstrated a significant inhibitory effect on tumor growth with two drug administration regimens. Furthermore, low doses of LMP-400 lowered the protein levels of hypoxia-inducible factor 1 (HIF-1 $\alpha$ ), one of a family of factors studied as potential metastatic drivers in these tumors. The HIF-1 $\alpha$  decrease resulted in changes in the mRNA levels of HIF-1 transcriptional targets. *In vitro*, LMP-400 showed an increase in the growth-inhibitory effects in combination with other chemotherapeutic drugs that are currently used for the treatment of PHEO. We concluded that LMP-400 had promising antitumor activity in preclinical models of metastatic PHEO and that its use should be considered in future clinical trial.

F<sub>1</sub>F<sub>0</sub> ATP synthase (ATP synthase) is a ubiquitous enzyme complex in eukaryotes. In general, it is localized in the mitochondrial inner membrane and serves as the last step in the mitochondrial oxidative phosphorylation of ADP to ATP, utilizing a proton gradient across the inner mitochondrial membrane built by the complexes of the electron transfer chain. However, some cell types, including tumors, carry ATP synthase on the cell surface. It has been suggested that cell-surface ATP synthase helps tumor cells thriving on glycolysis survive their high acid generation. Angiostatin, aurovertin, resveratrol, and antibodies against the  $\alpha$  and  $\beta$  subunits of ATP synthase were shown to bind to and selectively inhibit cell surface ATP synthase, promoting tumor cell death. We showed that ATP synthase  $\beta$  (ATP5B) is present on the cell surface of mouse PHEO cells as well as tumor cells of human *SDHB*-derived PGLs, while being virtually absent from chromaffin primary cells of bovine adrenal medulla, as shown by confocal microscopy. Using immuno-electron microscopy, we verified the cell-surface location of ATP5B in the tissue of an *SDHB*-derived PGL. Treatment of mouse PHEO cells with resveratrol as well as ATP5B antibody led to statistically significant inhibition of proliferation. Our data suggest that PGLs carry ATP synthase on their surface that promotes cell survival or proliferation. Thus, cell-surface ATP synthase may present a novel therapeutic target in treating metastatic or inoperable PGLs.

## Animal model of pheochromocytoma and cell culture studies

A major impediment to the development of effective treatments for metastatic or unresectable PPGL has been the absence of valid models for pre-clinical testing. Attempts to establish cell lines or xenografts from human PPGLs have previously been unsuccessful. NOD-scid gamma (NSG) mice are a recently developed

strain lacking functional B cells, T cells, and NK cells. We found that, in NSG mice, xenografts of primary human PGLs took, while maintaining the architectural and immuno-phenotypic characteristics expressed in the patients. In contrast to grafts of cell lines and of most common types of primary tumors, the growth rate of grafted PGLs is very slow, accurately representing the growth rate of most PPGLs, even in human metastases. Although the model is therefore technically challenging, primary patient-derived xenografts of PGLs in NSG mice provide a potentially important new tool that could prove especially valuable for testing treatments aimed at eradicating the small tumor deposits that are often numerous in patients with metastatic PGL.

## Publications

1. Darr R, Nambuba J, Del Rivero J, Janssen I, Merino M, Todorovic M, Balint B, Jochmanova I, Prchal JT, Lechan R, Tischler AS, Popovic V, Miljic D, Adams KT, Prall FR, Ling A, Golomb MR, Ferguson M, Nilubol N, Chen C, Chew E, Taieb D, Stratakis CA, Fojo A, Yang C, Kebebew E, Zhuang Z, Pacak K. Novel insights into the polycythemia-paraganglioma-somatostatinoma syndrome. *Endocr Relat Cancer* 2016 23(12):899-908.
2. Turkova H, Prodanov T, Maly M, Martucci V, Adams K, Widimsky J Jr, Chen CC, Ling A, Kebebew E, Stratakis CA, Fojo T, Pacak K. Characteristics and outcomes of metastatic and sporadic pheochromocytoma/paraganglioma: a National Institutes of Health study. *Endocr Practice* 2016 22:302-314.
3. Schovaneck J, Bullova P, Tayem Y, Giubellino A, Wesley R, Lendvai N, Nölting S, Kopacek J, Frysak Z, Pommier Y, Kummar S, Pacak K. Inhibitory effect of the noncamptothecin topoisomerase I inhibitor LMP-400 on female mice models and human pheochromocytoma cells. *Endocrinology* 2015 156:4094-4104.
4. Janssen I, Blanchet EM, Adams K, Chen CC, Millo CM, Herscovitch P, Taieb D, Kebebew E, Lehnert H, Fojo AT, Pacak K. Superiority of [68Ga]-DOTATATE PET/CT to other functional imaging modalities in the localization of SDHB-associated metastatic pheochromocytoma and paraganglioma. *Clin Cancer Res* 2016 21:3888-3895.
5. Fliedner SM, Shankavaram U, Marzouca G, Elkahloun A, Jochmanova I, Daerr R, Linehan WM, Timmers H, Tischler AS, Papaspyrou K, Brieger J, de Krijger R, Breza J, Eisenhofer G, Zhuang Z, Lehnert H, Pacak K. Hypoxia-inducible factor 2a mutation-related paragangliomas classify as discrete pseudohypoxic subcluster. *Neoplasia* 2016 18(9):567-576.

## Collaborators

- Clara C. Chen, MD, *Nuclear Medicine Department, Clinical Center, NIH, Bethesda, MD*
- Graeme Eisenhofer, PhD, *Universität Dresden, Dresden, Germany*
- Abdel G. Elkahloun, PhD, *Genome Technology Branch, NHGRI, NIH, Bethesda, MD*
- Alessio Imperiale, MD, PhD, *Hôpital de Hautepierre, Les Hôpitaux Universitaires de Strasbourg, Strasbourg, France*
- Electron Kebebew, MD, *Surgery Branch, NCI, Bethesda, MD*
- Ron Lechan, MD, PhD, *Tufts Medical Center, Boston, MA*
- Jacques Lenders, MD, *Radboud Universiteit, Nijmegen, The Netherlands*
- W. Marston Linehan, MD, *Urologic Oncology Branch, NCI, Bethesda, MD*
- Lani Mercado-Asis, MD, PhD, *University of Santo Tomas, Manila, Philippines*
- Alexander Ling, MD, *Radiology Department, Clinical Center, NIH, Bethesda, MD*
- Maria J. Merino, MD, *Pathology Department, NCI, Bethesda, MD*

- Corina Millo, MD, *PET Department, Clinical Center, NIH, Bethesda, MD*
- Margarita Raygada, PhD, *Division of Intramural Research, NICHD, Bethesda, MD*
- James C. Reynolds, MD, *Nuclear Medicine Department, Clinical Center, NIH, Bethesda, MD*
- Constantine A. Stratakis, MD, D(med)Sci, *Division of Intramural Research, NICHD, Bethesda, MD*
- David Taieb, MD, PhD, *Centre Européen de Recherche en Imagerie Médicale, Hôpital de la Timone, Marseille, France*
- Henri Timmers, MD, PhD, *Radboud Universiteit, Nijmegen, The Netherlands*
- Arthur S. Tischler, MD, PhD, *New England Medical Center, Boston, MA*
- Robert A. Wesley, PhD, *Clinical Epidemiology and Biostatistics Service, Clinical Center, NIH, Bethesda, MD*
- Zhengping Zhuang, MD, PhD, *Surgical Neurology Branch, NINDS, Bethesda, MD*

## Contact

For more information, email [karel@mail.nih.gov](mailto:karel@mail.nih.gov) or visit <https://science.nichd.nih.gov/confluence/display/pacak/Home>.

## Molecular Genetics of an Imprinted Gene Cluster on Mouse Distal Chromosome 7

Genomic imprinting is an unusual form of gene regulation by which an allele's parental origin restricts allele expression. For example, almost all expression of the non-coding RNA tumor suppressor gene *H19* is from the maternal chromosome. In contrast, expression of the neighboring insulin-like growth factor 2 gene (*Igf2*) is from the paternal chromosome. Imprinted genes are not randomly scattered throughout the chromosome but rather are localized in discrete clusters. One cluster of imprinted genes is located on the distal end of mouse chromosome 7 (Figure 1). The syntenic region in humans (11p15.5) is highly conserved in gene organization and expression patterns. Mutations disrupting the normal patterns of imprinting at the human locus are associated with developmental disorders and many types of tumors, including Wilms' tumor and rhabdosarcomas in children. In addition, inherited cardiac arrhythmia is associated with mutations in the maternal-specific *Kcnq1* gene. We use mouse models to address the molecular basis for allele-specific expression in this distal 7 cluster. We use imprinting as a tool to understand the fundamental features of epigenetic regulation of gene expression. We also generate mouse models for the several inherited disorders of humans, specifically models to study the effect of loss of imprinting at the *Igf2/H19* locus on cardiac development, the defects in cardiac repolarization associated with loss of *Kcnq1* function, and phenotypes associated with loss of *Calsequestrin2* gene function.

### Alternative long-range interactions between distal regulatory elements establish allele-specific expression at the *Igf2/H19* locus.

Our studies on the mechanisms of genomic imprinting focus on the *H19* and *Igf2* genes. Paternally expressed *Igf2* lies about 80 kb upstream of the maternal-specific *H19* gene. Using cell-culture systems as well as transgene and knockout experiments *in vivo*, we identified the enhancer elements responsible for activation of the two genes. The elements are shared and are all located downstream of the *H19* gene (Figure 2).

Imprinting at the *Igf2/H19* locus is dependent upon the 2.4 kb *H19* imprinting control region (H19 ICR), which lies between the two genes, just upstream of the *H19* promoter (Figure 2). On the maternal



**Karl Pfeifer, PhD, Head, Section on Genomic Imprinting**

Claudia Gebert, PhD, *Biologist*

Apratim Mitra, PhD, *Postdoctoral Fellow*

Beenish Rahat, PhD, *Postdoctoral Fellow*

Christopher Tracy, PhD, *Postdoctoral Fellow*

Ki-Sun Park, PhD, *Visiting Fellow*

Luke Brandenberger, BS, *Postbaccalaureate Fellow*

Daniel Flores, BS, *Postbaccalaureate Fellow*



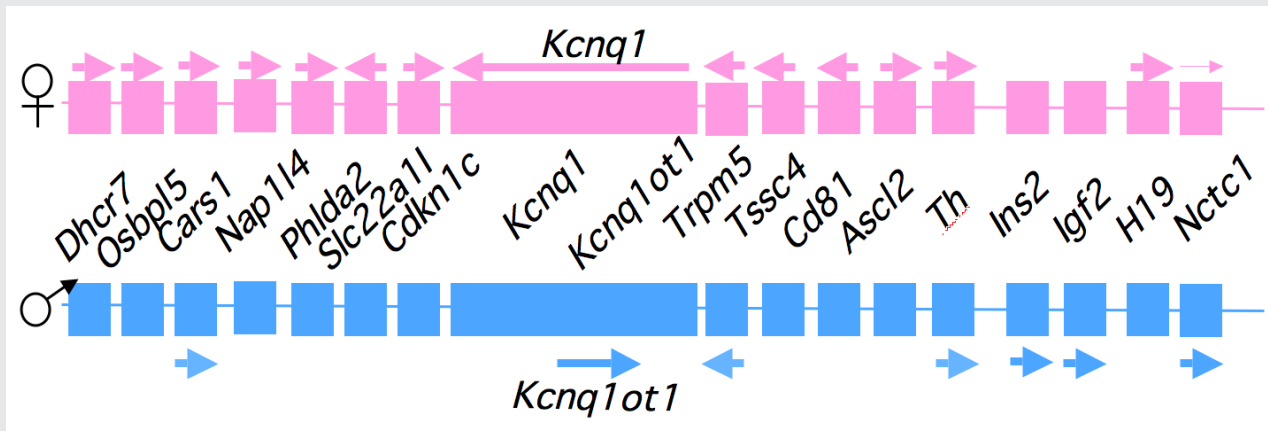

FIGURE 1. An imprinted domain on mouse distal chromosome 7

Maternal (*pink*) and paternal (*blue*) chromosomes are indicated. Horizontal arrows denote RNA transcription.

chromosome, binding of the CTCF protein, a transcriptional regulator, to the ICR establishes a transcriptional insulator that organizes the chromosome into loops. The loops favor *H19* expression but block interactions between the maternal *Igf2* promoters and the downstream shared enhancers, thus preventing maternal *Igf2* expression. Upon paternal inheritance, the CpG sites within the ICR are methylated, which prevents binding of the CTCF protein, so that a transcriptional insulator is not established. Thus, paternal *Igf2* promoters and the shared enhancers interact via DNA loops, and expression of paternal *Igf2* is facilitated. Altogether, we find that the fundamental role of the ICR is to organize the chromosomes into alternative 3-D configurations that promote or prevent expression of the *Igf2* and *H19* genes.

The *H19* ICR is not only necessary but is also sufficient for genomic imprinting. To demonstrate this, we used knock-in experiments to insert the 2.4 kb element at heterologous loci and demonstrated its ability to imprint these regions. Further, analyses of the loci confirmed and extended the transcriptional model described above. Upon maternal inheritance, even ectopic ICR elements remain unmethylated, bind to the CTCF protein, and form transcriptional insulators. Paternally inherited ectopic ICRs become methylated, cannot bind to CTCF, and therefore promote alternative loop domains distinct from those organized on maternal chromosomes. Most curious was the finding that DNA methylation of ectopic ICRs is not acquired until relatively late in development, after the embryo implants into the uterus. In contrast, at the endogenous locus ICR methylation occurs during spermatogenesis. The findings thus imply that DNA methylation is not the primary imprinting mark that distinguishes maternally from paternally inherited ICRs.

The *Nctc1* gene lies downstream of *H19* and encodes a long non-coding RNA that is transcribed across the muscle enhancer element (ME in Figure 2), which is shared by *Igf2* and *H19*. *Nctc1* expression depends on this enhancer element. Concordantly, the shared enhancer interacts with the *Nctc1* promoter just as it interacts with the maternal *H19* and the paternal *Igf2* promoters. We showed that all three co-regulated promoters (*Igf2*, *H19*, and *Nctc1*) also physically interact with each other in a manner that depends on their interactions with the shared enhancer. Thus, enhancer interactions with one promoter do not preclude interactions with another promoter. Moreover, we demonstrated that these promoter-promoter interactions are regulatory;

they explain the developmentally regulated imprinting of *Nctc1* transcription. Taken together, our results demonstrate the importance of long-range enhancer-promoter and promoter-promoter interactions in physically organizing the genome and establishing the gene expression patterns that are crucial for normal mammalian development (References 3, 4).

## Molecular mechanisms for tissue-specific promoter activation by distal enhancers

Normal mammalian development is absolutely dependent on establishing the appropriate patterns of expression of thousands of developmentally regulated genes. Most often, development-specific expression depends on promoter activation by distal enhancer elements. The *Igf2/H19* locus is a highly useful model system for investigating mechanisms of enhancer activation. First, the biological significance of the model is clear, given that expression of these genes is so strictly regulated. Even two-fold changes in RNA levels are associated with developmental disorders and with cancer. Second, we already know much about the enhancers in this region and have established powerful genetic tools to investigate their function. *Igf2* and *H19* are co-expressed throughout embryonic development and depend on a series of tissue-specific enhancers that lie between 8 and more than 150 kb downstream of the *H19* promoter (or between 88 and more than 130 kb downstream of the *Igf2* promoters). The endodermal and muscle enhancers have been precisely defined, and we generated mouse strains carrying deletions that completely abrogate enhancer function. We also generated insulator insertion mutations that specifically block muscle enhancer activity. We used these strains to generate primary myoblast cell lines so that we can combine genetic, molecular, biochemical, and genomic analyses to understand the molecular bases for enhancer functions.

### A LONG NON-CODING RNA IS AN ESSENTIAL ELEMENT OF THE MUSCLE ENHANCER (REFERENCE 4).

Transient transfection analyses define a 300-bp element that is both necessary and sufficient for maximal enhancer activity. However, stable transfection and mouse mutations indicate that this core element is not sufficient for enhancer function in a chromosomal context. Instead, the *Nctc1* promoter element is also essential. (The *Nctc1* gene encodes a spliced, polyadenylated long non-coding RNA). The *Nctc1* RNA itself is not required (at least in *trans*). Instead mutational analysis demonstrates that it is *Nctc1* transcription

FIGURE 2. Distinct maternal and paternal chromosomal conformations at the distal 7 locus

Epigenetic modifications on the 2.4 kb ICR generate alternative 3D organizations across a large domain on paternal (*blue*) and maternal (*pink*) chromosomes and thereby regulate gene expression. ICR, imprinting control region; ME, muscle enhancer; filled lollipops, CpG methylation covering the paternal ICR.

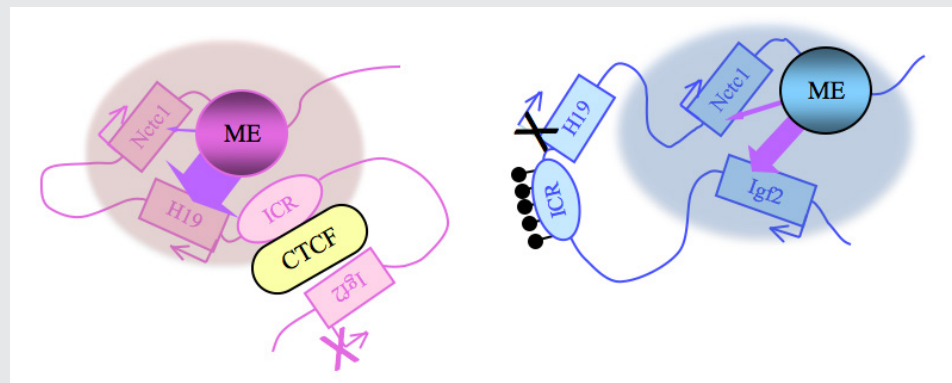

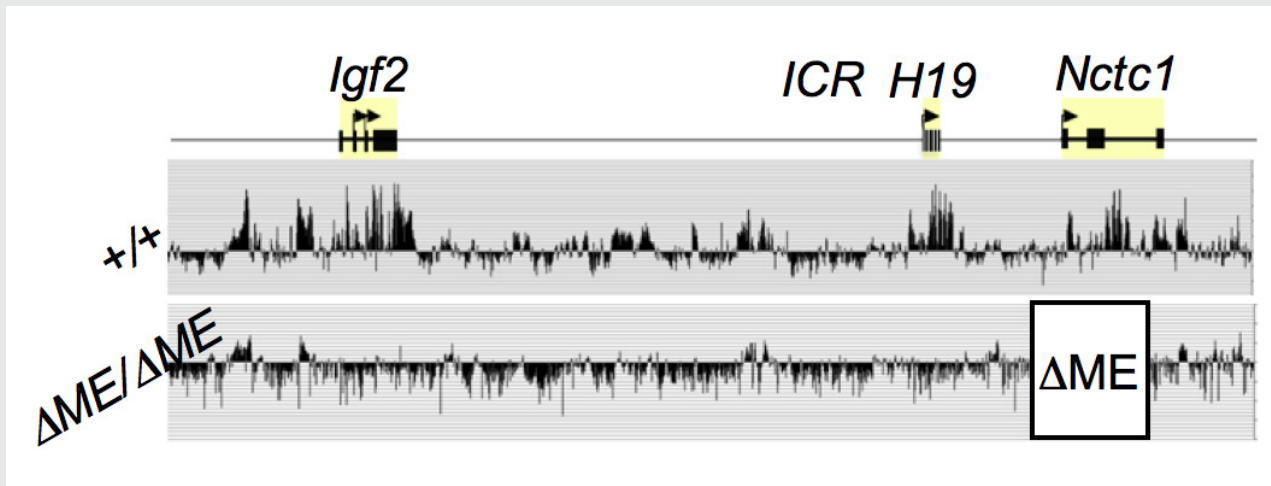

FIGURE 3. The shared muscle enhancer (ME) directs RNAP binding and RNA transcription across the entire 150 kb locus.

through the core enhancer that is necessary for enhancer function. Curiously, the *Nctc1* promoter has chromatin features typical of both a classic enhancer and a classic peptide-encoding promoter. Several recent genomic studies also suggested a role for non-coding RNAs in gene regulation and enhancer function. We will use our model system to characterize the role of *Nctc1* transcription in establishing enhancer orientation, enhancer promoter specificity, and enhancer tissue specificity.

**THE MUSCLE ENHANCER (ME) DIRECTS RNA POLYMERASE (RNAP) II NOT ONLY TO ITS COGNATE PROMOTERS (I.E., TO THE H19 AND IGF2 PROMOTERS) BUT ALSO ACROSS THE ENTIRE INTERGENIC REGION.**

We used ChIP-on-chip to analyze RNAP localization on chromatin prepared from wild-type and from enhancer-deletion (DME) cell lines (Figure 3). As expected, RNAP binding to the *H19* and *Igf2* promoters is entirely enhancer-dependent. Curiously, we also noted enhancer-dependent RNAP localization across the entire locus, including the large intergenic domain between the two genes. Furthermore, the RNAP binding is associated with RNA transcription. Thus, the enhancer regulates accessibility and RNAP binding not only at

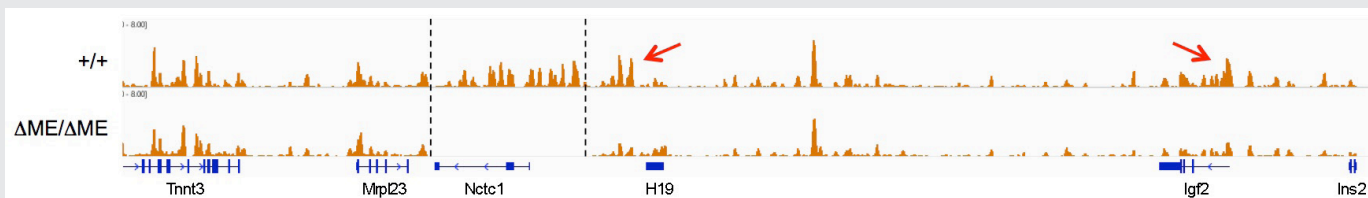

FIGURE 4. Chromatin patterns at the *Igf2/H19* locus are independent of enhancer activity.

Chromatin was isolated from wild-type and enhancer-deletion muscle cells using antibodies to H3K4me1 and analyzed by DNA sequencing.

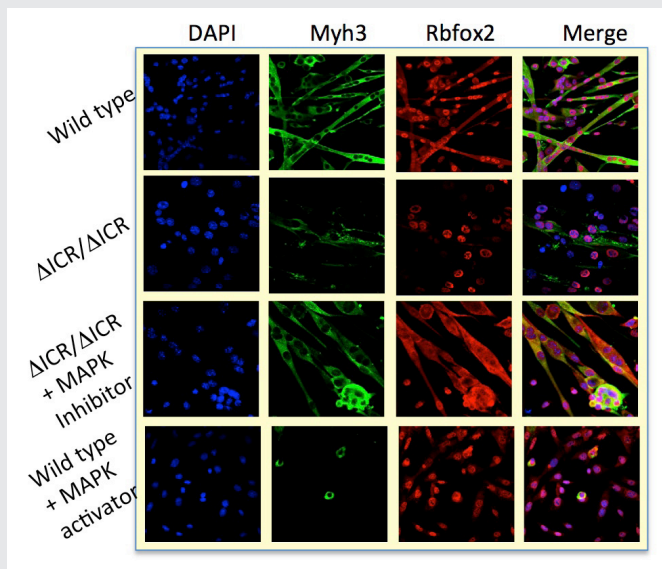

FIGURE 5. Muscle cell-differentiation defects in *Igf2/H19* loss-of-imprinting mice

Differentiation defects in loss-of-imprinting ( $\Delta$ ICR) myoblasts can be rescued by blocking MAP kinase 3 activity. Conversely, artificial activation of the MAPK activity in wild-type cells mimics the genetic defect.

transcription are not insulator-sensitive. The results indicate that insulators do not serve solely as a physical block for RNAP progression, but rather they specifically interfere with certain RNAP states or activities.

### THE MUSCLE ENHANCER REGULATES RNAP BINDING AND RNA TRANSCRIPTION BUT DOES NOT ESTABLISH CHROMATIN STRUCTURES.

Both RNA transcription and RNAP binding across the *Igf2/H19* domain are entirely dependent upon the muscle enhancer. For example, levels of *H19* RNA are reduced more than 10,000-fold in muscle cells in which the enhancer has been deleted. To test the dependence of chromatin structure on enhancer activity, we performed ChIP-Seq on wild-type and on enhancer-deletion cell lines using antibodies to the histones H3K4me1, H3K43me3, and H3K36me3. Surprisingly, we saw no changes in the patterns of chromatin modification (Figure 4). Thus, a functional enhancer and active RNA transcription are not important for establishing chromatin structures at this locus.

## Function of the *H19* and *Igf2* genes in muscle cell growth and differentiation

Misexpression of *H19* and *IGF2* is associated with several developmental diseases (including Beckwith-Wiedemann syndrome and Silver-Russell syndrome) and with several kinds of cancer, especially Wilms' tumor and rhabdosarcoma. In humans, misexpression is most often caused by loss-of-imprinting mutations that result in biallelic expression of *IGF2* and loss of expression of *H19*. We generated and characterized primary myoblast cell lines from mice carrying deletion of the *H19* imprinting control region (ICR) that phenocopies the loss-of-imprinting expression phenotypes; that is, ICR-deletion mice make extra *Igf2* but no *H19*. Mice carrying this mutation do not develop rhabdosarcoma but show defects in their ability

specific localized sites but across the entire domain. The results support a facilitated tracking model for enhancer activity.

### RNAP BINDING AT 'REAL' GENES AND ACROSS THE INTERGENIC REGIONS IS QUALITATIVELY DIFFERENT.

We used naturally occurring single nucleotide polymorphisms (SNPs) to investigate allelic differences in binding of RNAP and activation of gene expression in wild-type cells and in cells carrying enhancer deletions or insulator insertion mutations. RNAP binding across the *Igf2* and *H19* genes is both enhancer-dependent and insulator-sensitive; that is, a functional insulator located between an enhancer and its regulated gene prevents RNAP binding and likewise prevents RNA transcription. Across the intergenic regions, RNAP binding and RNA transcription are similarly enhancer-dependent (see above). However, intergenic RNAP binding and

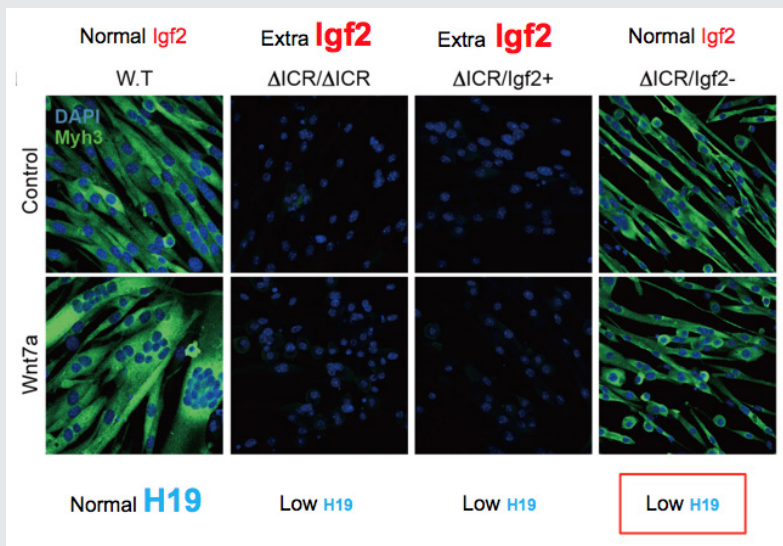

**FIGURE 6. The long noncoding H19 RNA is required for normal myotube fusion and hypertrophy.**

Loss-of-imprinting defects at the *Igf2*/*H19* locus result in extra expression of *Igf2* and defects in myotube differentiation: Compare WT (wild type) with  $\Delta$ ICR/ $\Delta$ ICR and  $\Delta$ ICR/*Igf2*<sup>+</sup> cells. Mutation of the paternal *Igf2* gene can restore normal *Igf2* expression levels and thus restore normal differentiation. (See  $\Delta$ ICR/*Igf2*<sup>-</sup> cells). However, these cells still do not make the H19 long noncoding RNA, do not fuse efficiently, and do not respond to Wnt7a signaling.

to respond to and to heal muscle injury. Moreover, primary myoblast lines derived from mutant mice are defective in their ability to differentiate *in vitro* (Figure 5) (Reference 5).

To understand the molecular basis for the differentiation phenotype, we performed RNA sequencing and identified several hundred genes whose expression levels are altered by the *ICR* deletion. GO (gene ontology) pathway analysis demonstrates that these differentially expressed genes were highly enriched in the MAP kinase signaling pathway. Of special note, expression of the *Mapk3* gene is increased almost 10-fold in mutant cell lines.

To determine the significance of the changes in *Mapk3*, we used drug inhibitors to block MAP kinase activity. In mutant cell lines, we can restore normal differentiation by blocking activation of the MAP kinase target MEK1. Similarly, treatments that activate MAP kinase in wild-type cells can mimic the *ICR*-deletion phenotype. The results suggest that *H19/Igf2* act through MAP kinase to regulate differentiation of myoblast cells.

To distinguish the roles of *Igf2* over-expression and *H19* under-expression, we analyzed additional mouse strains that restore *H19* via a bacterial artificial chromosome transgene or that restore normal levels of *Igf2* expression via a second mutation in the paternal *Igf2* gene. Analyses of cell lines from these mice demonstrate that extra *Igf2* is the direct cause of failure to differentiate in loss-of-imprinting mutations but that *H19* is essential for normal fusion and for muscle hypertrophy in response to Wnt pathways (Figure 6). Further molecular and genetic analyses will uncover the molecular pathways underlying these defects. Furthermore, to understand how the *H19* long noncoding RNA can accomplish its functions, we used CRISPR technology to mutagenize conserved domains within the *H19* gene, including sites that encode microRNAs and sites that bind to the let7 microRNA.

## Role of calsequestrin2 in regulating cardiac function

Mutations in the *CASQ2* gene, which encodes cardiac calsequestrin (CASQ2), are associated with catecholaminergic polymorphic ventricular tachycardia (CPVT) and sudden death. The survival of individuals

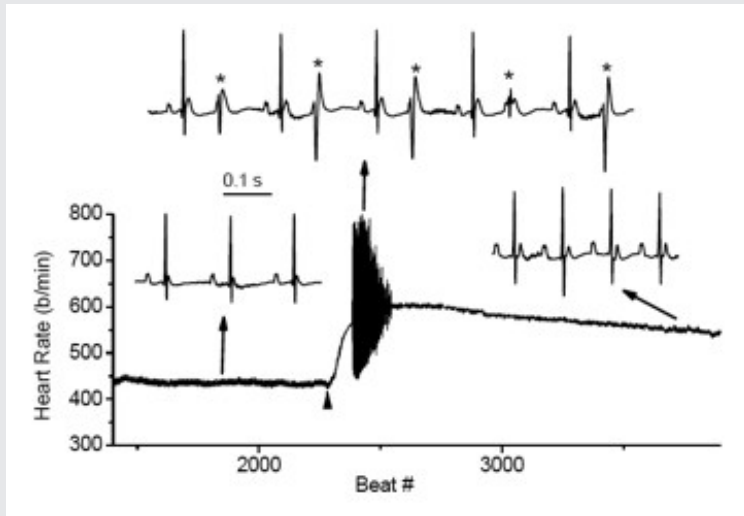

**FIGURE 7.** Cardiac arrhythmias in calsequestrin-2-deficient mice phenocopy the human disease.

Premature ventricular complexes (\*) are induced by stress in *Casq2*-deficient but not in wild-type mice.

homozygous for loss-of-function mutations in *CASQ2* was surprising, given the central role of  $\text{Ca}^{2+}$  ions in excitation-contraction (EC) coupling and the presumed critical roles of *CASQ2* in regulating  $\text{Ca}^{2+}$  release from the sarcoplasmic reticulum (SR) into the cytoplasm. To address this paradox, we generated a mouse model for loss of *Casq2* gene activity. Comprehensive analysis of cardiac function and structure yielded several important insights into *CASQ2* function. First, *CASQ2* is not essential to provide sufficient  $\text{Ca}^{2+}$  storage in the SR of the cardiomyocyte. Rather, a compensatory increase in SR volume and surface area in mutant mice appears to maintain normal  $\text{Ca}^{2+}$  storage capacity. Second, *CASQ2* is not required for the rapid, triggered release of  $\text{Ca}^{2+}$  from the SR during cardiomyocyte contraction. Rather, the RyR receptor, an intracellular calcium ion channel, opens appropriately, resulting in normal, rapid flow of  $\text{Ca}^{2+}$  into the cytoplasm, thus allowing normal contraction of the cardiomyocyte. Third, *CASQ2* is required for normal function of the RyR during cardiomyocyte relaxation. In the absence of *CASQ2*, significant  $\text{Ca}^{2+}$  leaks occur through the RyR and lead to premature contractions and cardiac arrhythmias (Figure 7). Fourth, *CASQ2* function is required to maintain normal levels of the SR proteins junctin and triadin. We do not yet understand what role, if any, the compensatory changes in these two SR proteins play in modulating the loss of *Casq2* phenotype.

To address these issues and to model cardiac disorders associated with late-onset (not congenital) loss of *CASQ2* activity, we established and are analyzing two new mouse models in which changes in *Casq2* gene structure are induced by tissue-specific transgenes activated by tamoxifen treatment. In the first model, an invested/null allele is restored to normal function by the addition of the drug. In the past year, we demonstrated the effectiveness of this model and noted that full *Casq2* protein levels are restored within one week of treatment. In the second model, a functional gene is ablated by the addition of the drug. The *Casq2* gene and mRNAs are deleted from cardiac cells within four days of hormone treatment. Phenotypic analyses shows that restoration of *Casq2* in adult animals is sufficient to fully restore cardiac function. Moreover, restoration solely in pacemaking cells is also enough to rescue function, suggesting an important role for reduced heart rate in the CPVT phenotype as well as a new target for therapeutic interventions.

## Publications

1. De S, Mitra A, Cheng Y, Pfeifer K, Kassis, JA. Formation of a polycomb-domain in the absence of strong polycomb response elements. *PLoS Genet* 2016 12:e1006200.
2. Ray P, De S, Mitra A, Bezstarosti K, Demmers JA, Pfeifer K, Kassis JA. Compgap contributes to recruitment of Polycomb group proteins in *Drosophila*. *Proc Natl Acad Sci USA* 2016 113:3826-3831.
3. Eun B, Sampley ML, Good AL, Gebert CM, Pfeifer K. Promoter cross-talk via a shared enhancer explains paternally biased expression of Nctc1 at the Igf2/H19/Nctc1 locus. *Nucleic Acids Res* 2013 41:817-826.
4. Eun B, Sampley ML, Van Winkle MT, Good AL, Kachman MM, Pfeifer K. The Igf2/H19 muscle enhancer is an active transcriptional complex. *Nucleic Acids Res* 2013 41:8126-8134.
5. Dey BK, Pfeifer K, Duta, A. The H19 long non-coding RNA gives rise to microRNAs miR-675-3p and -5p to promote skeletal muscle differentiation and regeneration. *Genes Dev* 2014 28:491-501.

## Collaborators

- Leonid V. Chernomordik, PhD, *Section on Membrane Biology, NICHD, Bethesda, MD*
- Bjorn Knollmann, MD, PhD, *Vanderbilt University Medical Center, Nashville, TN*
- Mark D. Levin, MD, *Cardiovascular & Pulmonary Branch, NHLBI, DIR, Bethesda, MD*
- Paul Love, MD, PhD, *Section on Cellular and Developmental Biology, NICHD, Bethesda, MD*
- Danielle A. Springer, VMD, DCLAM, *Animal Program, NHLBI, Bethesda, MD*

## Contact

For more information, email [kpfeifer@helix.nih.gov](mailto:kpfeifer@helix.nih.gov) or visit <http://pfeiferlab.nichd.nih.gov>.

## Cholesterol Homeostasis and Genetic Syndromes

We study the molecular, biochemical, and cellular processes that underlie genetic disorders resulting from impaired cholesterol homeostasis. The disorders include malformation/cognitive impairment syndromes resulting from inborn errors of cholesterol synthesis and neurodegenerative disorders resulting from impaired intracellular cholesterol and lipid transport. Human malformation syndromes attributable to inborn errors of cholesterol synthesis include Smith-Lemli-Opitz syndrome (SLOS), lathosterolosis, desmosterolosis, X-linked dominant chondrodysplasia punctata type 2 (CDPX2), and the CHILD syndrome. Niemann-Pick disease type C (NPC) results from impaired intracellular transport of cholesterol and lipids, leading to neuronal loss. Our basic research uses mouse models of these genetic disorders to understand the biochemical, molecular, cellular, and developmental processes that underlie the birth defects and clinical problems encountered in affected patients. Our clinical research focuses on translating basic findings to the clinic. Natural history trials of both SLOS and NPC1 are ongoing. Our emphasis on both basic and clinical research allows us to integrate laboratory and clinical data in order to increase our understanding of the pathological mechanisms underlying both SLOS and NPC, with the goal of improving clinical care of these patients. Therapeutic trials have been conducted for both disorders, and we are completing a Phase I/IIa therapeutic trial of intrathecal 2-hydroxypropyl-beta-cyclodextrin (VTS-270) for NPC1, and a multicenter, multinational clinical efficacy trial of intrathecal VTS-270 was initiated in the fall of 2015. Over the past year, we also completed a Phase I/IIa trial of vorinostat (Zolinza) for the treatment of NPC1.

### Inborn errors of cholesterol synthesis

#### SMITH-LEMLI-OPITZ SYNDROME (SLOS)

SLOS is an autosomal recessive, multiple-malformation syndrome characterized by dysmorphic facial features, cognitive impairment, hypotonia, poor growth, and variable structural anomalies of heart, lungs, brain, limbs, gastrointestinal tract, and genitalia. The SLOS phenotype is extremely variable. At the severe end of the phenotypic spectrum, infants often die as result of multiple major malformations, while mild SLOS combines minor physical malformations with



**Forbes D. Porter, MD, PhD,**  
*Head, Section on Molecular  
Dysmorphology*

Chris A. Wassif, PhD, *Staff Scientist*

Niamh Cawley, PhD, *Staff Scientist*

Celine Cluzeau, PhD, *Postdoctoral  
Fellow*

Antony Cougnoux, PhD,  
*Postdoctoral Fellow*

Kevin Francis, PhD, *Postdoctoral  
Fellow*

Kyle Martin, PhD, *Postdoctoral  
Fellow*

Wei-Chia Tseng, PhD, *Postdoctoral  
Fellow*

Ian M. Williams, PhD, *Postdoctoral  
Fellow*

Nicole M. Yanjanin, CPNP, *Nurse  
Practitioner*

Joanna Cross, BA, *Wellcome Trust  
Student*

Emily Leff, BA, *Postbaccalaureate  
Intramural Research Training  
Award Fellow*

Jackie Picache, BA,  
*Postbaccalaureate Intramural  
Research Training Award Fellow*

*(continued)*



behavioral and learning problems. The syndrome is attributable to an inborn error of cholesterol biosynthesis that blocks the conversion of 7-dehydrocholesterol (7-DHC) to cholesterol.

Our laboratory initially cloned the human  $3\beta$ -hydroxysterol  $\Delta 7$ -reductase gene (*DHCR7*) and demonstrated mutations of the gene in SLOS patients. Together with others, we have so far identified over 100 mutations of *DHCR7*. We also used gene targeting in murine embryonic stem cells to produce several SLOS mouse models, including a null deletion and a hypomorphic point mutation. Mouse pups homozygous for the null mutation (*Dhcr7* <sup>$\Delta 3-5/\Delta 3-5$</sup> ) exhibit variable craniofacial anomalies, are growth-retarded, feed poorly, appear weak, and die during the first day of life because they fail to feed. Thus, we were not able to use them to study postnatal brain development, myelination, or behavior or to test therapeutic interventions. For this reason, we developed a mis-sense allele (*Dhcr7*<sup>T93M</sup>). The T93M mutation is the second most common mutation found in SLOS patients. *Dhcr7*<sup>T93M/T93M</sup> and *Dhcr7*<sup>T93M/ $\Delta 3-5$</sup>  mice are viable and demonstrate SLOS with a gradient of biochemical severity (*Dhcr7* <sup>$\Delta 3-5/\Delta 3-5$</sup>  > *Dhcr7*<sup>T93M/ $\Delta 3-5$</sup>  > *Dhcr7*<sup>T93M/T93M</sup>). We used *Dhcr7*<sup>T93M/ $\Delta 3-5$</sup>  mice to test the efficacy of therapeutic interventions on tissue sterol profiles. As expected, dietary cholesterol therapy improved the sterol composition in peripheral tissues but not in the central nervous system. Treatment of mice with the statin simvastatin improved the biochemical defect in both peripheral and central nervous system tissue, suggesting that simvastatin therapy may be used to treat some of the behavioral and learning problems in children with SLOS. Most recently, we developed a zebrafish model for SLOS that will allow us to study the impact of aberrant cholesterol synthesis on behavior. Characterization of induced pluripotent stem cells from SLOS patients demonstrated a defect in neurogenesis. The defect in neurogenesis results from inhibition of Wnt signaling owing to a toxic effect of 7-DHC

As part of our clinical studies on SLOS, we identified a novel oxysterol, 27-hydroxy-7-dehydrocholesterol (27-7DHC), derived from 7-DHC in SLOS patients. We therefore investigated whether 27-7DHC contributes to the pathology of SLOS and found a strong negative correlation between plasma 27-7DHC and cholesterol levels in these patients. In addition, previous work showed that low cholesterol levels impair hedgehog signaling. Therefore, we hypothesized that increased 27-7DHC levels would have detrimental effects during development as a result of suppression of cholesterol levels. To test our hypothesis, we produced SLOS mice (*Dhcr7* <sup>$\Delta 3-5/\Delta 3-5$</sup> ) expressing a *CYP27* (sterol 27-hydroxylase) transgene. *CYP27Tg* mice display increased *CYP27* expression and elevated 27-hydroxycholesterol levels but normal cholesterol levels. While *Dhcr7* <sup>$\Delta 3-5/\Delta 3-5$</sup>  mice are growth-retarded, exhibit a low incidence of cleft palate (9%), and die during the first day of life, *Dhcr7* <sup>$\Delta 3-5/\Delta 3-5$</sup> :*CYP27Tg* embryos are stillborn and have multiple malformations, including growth retardation, micrognathia, cleft palate (77%), lingual and dental hypoplasia, ankyloglossia, umbilical hernia, cardiac defects, cloacae, curled tails, and limb defects. We observed autopod defects (polydactyly, syndactyly, and oligodactyly) in 77% of the mice. Consistent with our hypothesis, sterol levels were halved in the liver and 20-fold lower in the brain tissue of *Dhcr7* <sup>$\Delta 3-5/\Delta 3-5$</sup> :*CYP27Tg* than in *Dhcr7* <sup>$\Delta 3-5/\Delta 3-5$</sup>  embryos. The fact that 27-7DHC plays a role in SLOS may explain some of the phenotypic variability and may lead to development of a therapeutic intervention. The project is a good example of the benefits of integrating clinical and basic science to both understand the pathology of SLOS and develop potential therapeutic interventions.

Caitlin Sojka, BA,  
*Postbaccalaureate Intramural  
Research Training Award Fellow*

Grace Weon, BA,  
*Postbaccalaureate Intramural  
Research Training Award Fellow*

Kathryn Burkert, BA, *Technical  
Intramural Research Training  
Award Fellow*

Alex Salman, BA, *Technical  
Intramural Research Training  
Award Fellow*

Ryan Lee, MD, *Special Volunteer*

Elaine Tierney, MD, *Special  
Volunteer*



FIGURE 1.

Dr. Porter and one of our patients. Neurological exams in children frequently involve 'playing' with the child.

To gain insight into pathophysiological processes contributing to SLOS, we completed a series of proteomic experiments to identify proteins that are differentially expressed in the cortex of *Dhcr7*<sup>Δ3-5/Δ3-5</sup> embryos. Functional analysis demonstrated alterations in the Rho/Rac-LIMK-Cofilin pathway that result in altered dendrite and axon formation. The defect in neuronal development may contribute to the cognitive deficits found in SLOS.

We are conducting a longitudinal Natural History trial. Given that SLOS patients have a cholesterol deficiency, they may be treated with dietary cholesterol supplementation. To date, we have evaluated over 75 SLOS patients. As part of a Bench-to-Bedside proposal, we continue, in collaboration with Fran Platt's laboratory, to study impaired

cholesterol and glycosphingolipid transport in SLOS and to investigate novel therapeutic interventions.

One reason for studying rare genetic disorders is to gain insight into more common disorders. Most patients with SLOS exhibit autistic characteristics. We are currently collaborating with other NIH and extramural groups to evaluate this further.

### LATHOSTEROLOSIS, DESMOSTEROLOSIS, AND HEM DYSPLASIA

Lathosterol 5-desaturase catalyzes the conversion of lathosterol to 7-dehydrocholesterol, representing the enzymatic step immediately preceding the defect in SLOS. Thus, to gain a deeper understanding of the roles of reduced cholesterol versus elevated 7-dehydrocholesterol in SLOS, we disrupted the mouse lathosterol 5-desaturase gene (*Sc5d*) by using targeted homologous recombination in embryonic stem cells. *Sc5d*<sup>-/-</sup> pups are stillborn, present with micrognathia and cleft palate, and exhibit limb-patterning defects. Many of the malformations in the mutant mice resemble malformations in SLOS and are consistent with impaired hedgehog signaling during development. Biochemically, the mice exhibit markedly elevated lathosterol levels and reduced cholesterol levels in serum and tissue.

A goal of producing a lathosterolosis mouse model was to gain phenotypic insight so we could identify a corresponding human malformation syndrome. We identified a human infant patient with lathosterolosis, a malformation syndrome not previously described in humans. Biochemically, fibroblasts from the patient show reduced cholesterol and elevated lathosterol levels. Mutation analysis showed that the patient is homozygous for a single A→C nucleotide change at position 137 in *SC5D*, resulting in a mutant enzyme in

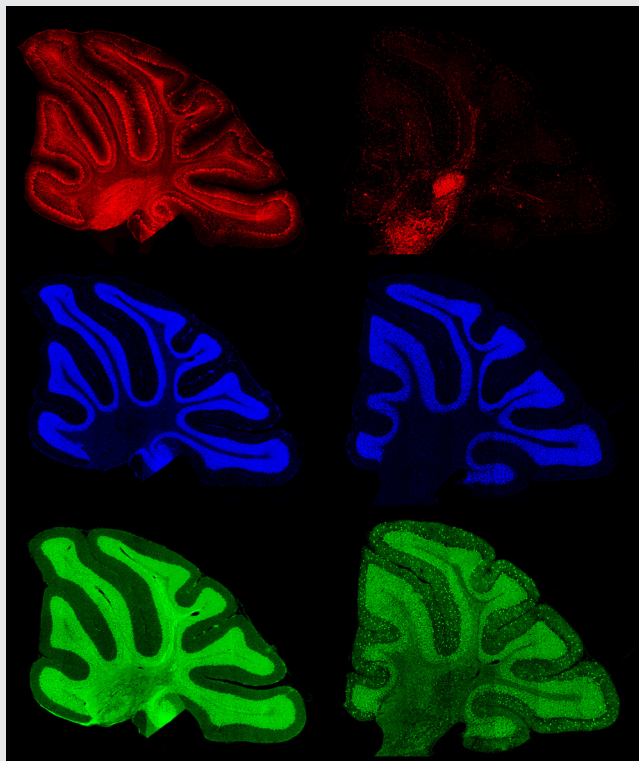

**FIGURE 2. Comparison of control and late-stage NPC1 mouse cerebellum**

Left: A sagittal cerebellar section from a control mouse is depicted, using fluorescent staining against a neuronal marker SMI32 (*red*), nuclear counterstain DAPI (*blue*), and lipid GM1 (*green*). Right: A comparable section from an *Npc1*-mutant mouse; note the extreme loss of Purkinje neurons (*red*), the perturbation of myelination (deep cerebellar tissue in *green*), and the green punctate accumulations of the ganglioside GM1 in the outermost cerebellar layer that are characteristic of the endo-lysosomal lipid storage found in this disorder.

which the amino acid serine is substituted for tyrosine at position 46. Both parents are heterozygous for the mutation. The infant's phenotype resembled severe SLOS. Malformations found in both the human patient and the mouse model include growth failure, abnormal nasal structure, abnormal palate, micrognathia, and postaxial polydactyly. A unique feature of lathosterolosis is the clinical finding of mucopolipidosis in the affected infant, which is not reported in SLOS and may help distinguish SLOS clinically from lathosterolosis. Lathosterolosis, which is a lysosomal storage disorder, may be replicated in embryonic fibroblasts from the *Sc5d*-mutant mouse model. To distinguish pathological changes attributable to reduced cholesterol in lathosterolosis from those that are a consequence of elevated 7-DHC in SLOS, we are comparing proteomic changes in the *Sc5d*-mutant mouse model with those in the SLOS mouse model. We recently developed induced pluripotent stem cells from lathosterolosis fibroblasts. Their characterization is in progress.

Desmosterolosis is another inborn error of cholesterol synthesis that resembles SLOS. It results from a mutation in the  $3\beta$ -hydroxysterol  $\Delta$ 24-reductase gene (*DHCR24*). *DHCR24* catalyzes the reduction of desmosterol to cholesterol. We disrupted the mouse *Dhcr24* gene with targeted homologous recombination in embryonic stem cells. Surprisingly, although most *Dhcr24* mutant mice die at birth, the pups are phenotypically normal.

Others have shown that mutations of the lamin B receptor (LBR) cause HEM (hydrops, ectopic calcification, moth-eaten skeletal) dysplasia in humans and ichthyosis in mice. LBR has both lamin B-binding and sterol  $\Delta$ 14-reductase domains. Although only a minor sterol abnormality has been reported, it was proposed that LBR is the primary sterol  $\Delta$ 14-reductase and that impaired sterol  $\Delta$ 14-reduction underlies HEM dysplasia. However, *DHCR14* also encodes a sterol  $\Delta$ 14-reductase. To test the hypothesis that LBR and *DHCR14* are redundant

sterol  $\Delta 14$ -reductases, we obtained ichthyosis mice (*Lbr Sc5d<sup>-/-</sup>*) and disrupted *Dhcr14*. *Dhcr14 Sc5d<sup>-/-</sup>* mice are phenotypically normal. We found no sterol abnormalities in either *Lbr Sc5d<sup>-/-</sup>* or *Dhcr14 Sc5d<sup>-/-</sup>* tissues at one or 21 days of age. We then bred the mice to obtain compound mutant mice. *Lbr Sc5d<sup>-/-</sup>;Dhcr14 Sc5d<sup>-/-</sup>* and *Lbr Sc5d<sup>-/-</sup>;Dhcr14<sup>+/-</sup>* died *in utero*. *Lbr<sup>+/-</sup>;Dhcr14 Sc5d<sup>-/-</sup>* mice appeared normal at birth but, by 10 days of age, were growth-retarded and neurologically abnormal (with ataxia and tremors) and, consistent with a demyelinating process, evidenced vacuolation and swelling of myelin sheaths in the spinal cord upon pathology evaluation. We observed neither vacuolation nor swelling of myelin sheaths in either *Lbr Sc5d<sup>-/-</sup>* or *Dhcr14 Sc5d<sup>-/-</sup>* mice. In contrast to *Lbr Sc5d<sup>-/-</sup>* mice, *Lbr<sup>+/-</sup>;Dhcr14 Sc5d<sup>-/-</sup>* mice had normal skin and did not display the Pelger-Huët anomaly (defect of terminal neutrophil differentiation as a result of mutations in the *LBR* gene). Peripheral tissue sterols were normal in all three mutant mice, although we found significantly elevated levels (50% of total sterols) of cholesta-8,14-dien-3 $\beta$ -ol and cholesta-8,14,24-trien-3 $\beta$ -ol in brain tissue from 10-day-old *Lbr<sup>+/-</sup>;Dhcr14 Sc5d<sup>-/-</sup>* mice. In contrast, we observed relatively small transient elevations in  $\Delta^{14}$ -sterol levels in *Lbr Sc5d<sup>-/-</sup>* and *Dhcr14 <sup>$\Delta^{4-7}/\Delta^{4-7}$</sup>*  brain tissue. Our data support the notion that HEM dysplasia and ichthyosis result from impaired lamin B receptor function rather than from impaired sterol  $\Delta 14$ -reduction. Impaired sterol  $\Delta 14$ -reduction gives rise to a novel murine phenotype for which a corresponding human disorder has yet to be identified.

## Niemann-Pick disease, type C1

Niemann-Pick disease, type C1 (NPC1) is a neurodegenerative disorder that results in ataxia and dementia. In view of the dementia, it has been referred to as childhood Alzheimer's disease. The disorder is caused by a defect in intracellular lipid and cholesterol transport. Initially, as part of a Bench-to-Bedside award, we began a clinical protocol to identify and characterize biomarkers that could be used in a subsequent therapeutic trial. The project also received support from the Ara Parseghian Medical Research Foundation and Dana's Angels Research Trust. We have enrolled over 85 NPC1 patients in a longitudinal Natural History trial. The goals of the trial are to identify (1) a blood-based diagnostic/screening test, (2) biomarkers that can be used as tools to facilitate development and implementation of therapeutic trials, and (3) clinical symptoms/signs that may be used as efficacy outcome measures in a therapeutic trial.

Currently, the average time from first symptom to diagnosis, the 'diagnostic delay,' in our cohort of NPC patients is on the order of four to five years. In collaboration with Daniel Ory, we found elevated levels of non-enzymatically produced oxysterols in NPC1 patients. As well as a potential biomarker that may be used to follow therapeutic interventions, the oxysterols will likely form the basis of a blood-based diagnostic test that will significantly shorten the diagnostic delay encountered by NPC1 patients.

In addition to our Natural History study, we completed a randomized, placebo-controlled, cross-over trial to investigate the safety and efficacy of *N*-acetyl cysteine (NAC) in NPC1. The goal was to determine whether NAC treatment would reduce oxidative stress and subsequently lower levels of the non-enzymatically produced oxysterols. In collaboration with the Therapeutics of Rare and Neglected Disease Program of NCATS, we are conducting a phase 1/2a therapeutic trial of lumbar intrathecal cyclodextrin therapy in NPC1. We have now transitioned to a multicenter, multinational phase 2b/3 trial.

In collaboration with Daniel Ory and Frederick Maxfield, our group was awarded an NIH U01 grant to test the safety and potential efficacy of an HDAC inhibitor, vorinostat, in adult NPC1 patients. The collaboration also includes scientists from Notre Dame and has been supported by the Ara Parseghian Medical Research Foundation.

To complement the clinical work, we have begun to apply molecular and proteomic approaches to both mouse and human biomaterials to identify biological pathways disrupted in NPC1. We identified several blood and cerebral spinal fluid proteins and are in the process of validating the biomarkers as potential outcome measures to be used as tools in the development of therapeutic interventions.

## Additional Funding

- U01HD079065: A Phase 1 Dose Escalation Study of Vorinostat in Niemann-Pick C1 Disease

## Publications

1. Porter FD, Scherrer DE, Lanier MH, Langmade SJ, Molugu V, Gale SE, Olzeski D, Sidhu R, Dietzen DJ, Fu R, Wassif CA, Yanjanin NM, Marso SP, House J, Vite C, Schaffer JE, Ory DS. Cholesterol oxidation products are sensitive and specific blood-based biomarkers for Niemann-Pick C1 disease. *Sci Transl Med* 2010 2:56ra81.
2. Wassif CA, Cross JL, Iben J, Sanchez-Pulido L, Cougnoux A, Platt FM, Ory DS, Ponting CP, Bailey-Wilson JE, Biesecker LG, Porter FD. High incidence of unrecognized visceral/neurological late-onset Niemann-Pick disease, type C1 predicted by analysis of massively parallel sequencing data sets. *Genet Med* 2016 18(1):41-48.
3. Francis KR, Ton AN, Xin Y, O'Halloran PE, Wassif CA, Malik N, Williams IM, Cluzeau CV, Trivedi NS, Pavan WJ, Cho W, Westphal H, Porter FD. Modeling Smith-Lemli-Opitz syndrome with induced pluripotent stem cells reveals a causal role for Wnt/beta-catenin defects in neuronal cholesterol synthesis phenotypes. *Nat Med* 2016 22:388-396.
4. Cougnoux A, Cluzeau C, Mitra S, Li R, Williams I, Burkert K, Xu X, Wassif CA, Zheng W, Porter FD. Necroptosis in Niemann-Pick disease, type C1: a potential therapeutic target. *Cell Death Dis* 2016 7:e2147.
5. Wassif CA, Kratz L, Sparks SE, Wheeler C, Bianconi S, Gropman A, Calis KA, Kelley RI, Tierney E, Porter FD. A placebo-controlled trial of simvastatin therapy in Smith-Lemli-Opitz syndrome. *Genet Med* 2016; Epub ahead of print.

## Collaborators

- Joan Bailey-Wilson, PhD, *Inherited Diseases Research Branch, NHGRI, Bethesda, MD*
- Paul Helquist, PhD, *University of Notre Dame, Notre Dame, IN*
- Frederick R. Maxfield, PhD, *Weill Cornell Medical College, New York, NY*
- Daniel Ory, MD, *Washington University, St. Louis, MO*
- William Pavan, PhD, *Genetic Disease Research Branch, NHGRI, Bethesda, MD*
- Fran Platt, PhD, *Oxford University, Oxford, United Kingdom*
- Elaine Tierney, MD, *Kennedy-Krieger Institute, Baltimore, MD*
- Charles Vite, DVM, *University of Pennsylvania, Philadelphia, PA*
- Olaf G. Wiest, Dr rer nat, *University of Notre Dame, Notre Dame, IN*
- Alfred Yergey, PhD, *Mass Spectrometry Core Facility, NICHD, Bethesda, MD*
- The Therapeutics for Rare & Neglected Diseases (TRND) Team, *NCATS, NIH, Bethesda, MD*

## Contact

For more information, email [fdporter@helix.nih.gov](mailto:fdporter@helix.nih.gov) or visit <https://irp.nih.gov/pi/forbes-porter>.

## Mechanisms of Disease in Preterm Labor and Complications of Prematurity; Prenatal Diagnosis of Congenital Anomalies

Preterm birth is the leading cause of perinatal morbidity and mortality worldwide. The cost of prematurity in the U.S. alone is estimated to be \$26 billion per year. An important goal is to understand the mechanisms of disease responsible for spontaneous preterm birth and fetal injury and to develop methods for the prediction and prevention of preterm birth.

The Perinatology Research Branch (PRB) has proposed that preterm parturition is a syndrome caused by multiple pathologic processes (Preterm labor: one syndrome, many causes. *Science* 2014;345:760; also Figure 1). The emphasis of our Branch has been to study intra-amniotic infection and inflammation, vascular disorders, maternal anti-fetal rejection (chronic inflammatory lesions of the placenta), cervical disease, and a decline in progesterone action. This year, we report that point-of-care tests can be employed for the rapid diagnosis of intra-amniotic inflammation (within 20 minutes) and also evidence that a new combination of antimicrobial agents can reduce the risk of adverse pregnancy outcome and histologic inflammation. Given that one third of all preterm deliveries are the result of physician-initiated birth owing to preeclampsia or intrauterine growth restriction, we also studied the role of biomarkers in the prediction of indicated preterm delivery in mothers carrying small-for-gestational age fetuses. We report for the first time biomarkers for the presence of placental histologic lesions consistent with maternal vascular under-perfusion. The lesions underlie most cases of fetal death, preeclampsia, severe and early fetal growth restriction, and a fraction of spontaneous preterm labor.

The Branch also studies other obstetrical syndromes that account for the high rate of infant mortality in the United States, including clinical chorioamnionitis, which is the most common infection-related diagnosis in delivery units around the world, as well as meconium aspiration syndrome and amniotic fluid embolism.

Congenital anomalies continue to be a leading cause of perinatal mortality in the United States. A powerful tool for scientific discovery, imaging has changed the practice of obstetrics and maternal-fetal medicine. Imaging with ultrasound allows the definition of fetal anatomy, biometry, growth, and the study of physiologic parameters,



**Roberto Romero, MD, DMedSci,**  
*Chief, Perinatology Research  
Branch*

such as cardiac function, fetal sleep, and breathing. Our studies with three-dimensional and four-dimensional ultrasound continue as does the clinical testing of fetal intelligent navigation echocardiography (FINE), a technology invented by our Branch and licensed and commercially available.

Although ultrasound is the standard imaging modality in pregnancy, magnetic resonance imaging (MRI) has also been used to characterize fetal anatomy when ultrasound cannot provide definitive diagnostic answers. MRI provides unique information about fetal physiologic parameters (i.e., perfusion, oxygenation, and biochemistry) that are outside the domain of ultrasound. Moreover, MRI can be used to characterize the ontogeny of functional neuroconnectivity, as well as the potential relationship between insults which could alter fetal neurodevelopment. We therefore developed methods to use quantitative MRI to gain insight into the fetal brain anatomy and physiology.

## Progesterone for the prevention of preterm birth in women with a short cervix

We previously reported the results of the PREGNANT trial and an individual patient meta-analysis, as well as a cost-effective analysis, indicating that vaginal progesterone given to patients with a short cervix reduces the rate of preterm birth (less than 33 weeks of gestation) by 45%, admission to the NICU, respiratory distress syndrome, requirement for mechanical ventilation, and neonatal morbidity. This has led to a change in practice, as professional organizations (American Congress of Obstetricians and Gynecologists, Society for Maternal-Fetal Medicine) have recommended treatment with vaginal progesterone to patients with a short cervix. The International Federation of Gynecology and Obstetrics (FIGO) has endorsed universal cervical screening to identify patients at risk for preterm delivery and the administration of vaginal progesterone to prevent preterm birth.

In February 2016, investigators in the U.K. reported results of the OPPTIMUM trial (a multi-center, randomized, double-blind trial of vaginal progesterone prophylaxis for preterm birth). This trial enrolled (1) 903 patients with a prior history of previous spontaneous preterm birth at less than 34 weeks; (2) 251 patients with a short cervix (less than 25mm); and (3) patients with a positive fetal fibronectin test combined with other clinical risk factors for preterm birth. Overall, the investigators reported that vaginal progesterone did not reduce the rate of preterm birth. However, we (and others) believe that this was attributable to important limitations in study design, as well as inadequate sample size and compliance. Indeed, there was a non-significant trend towards a reduction in preterm delivery in patients with a cervical length of less than 25mm.

We contacted the authors to perform an individual patient meta-analysis and, in the meantime, performed a systematic review and aggregate meta-analysis. We uncovered that the OPPTIMUM trial was at high risk for attrition, reporting, and compliance biases.

Importantly, we found that after adding the results of the OPPTIMUM trial to our previous individual patient data meta-analysis, vaginal progesterone significantly reduced the rate of preterm birth. We are expecting delivery of the data from the OPPTIMUM investigators to conduct an individual patient meta-analysis (as agreed upon with Dr. Jane Norman at the Royal College of Obstetricians and Gynecologists meeting in October, 2016).

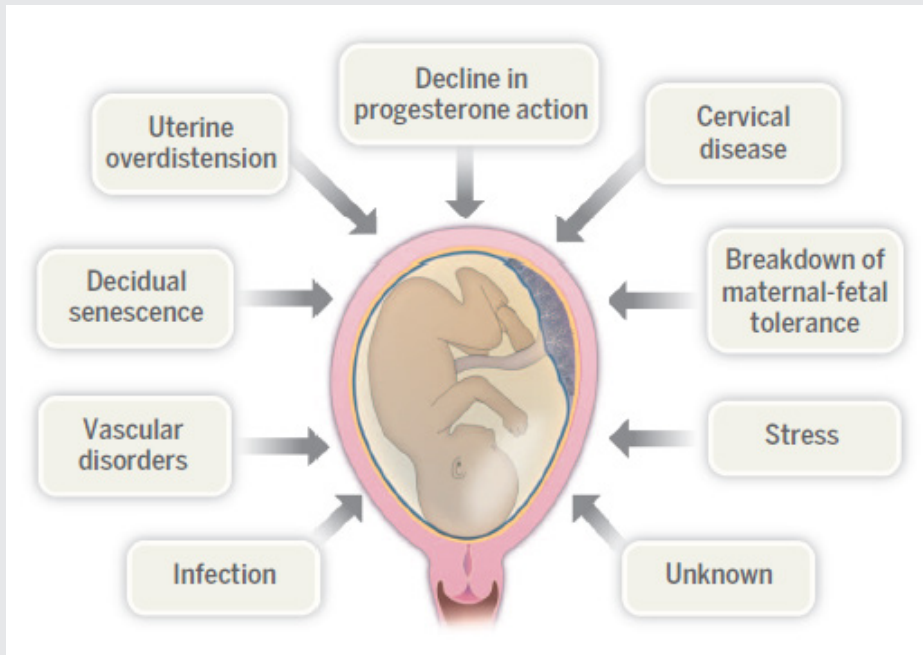

**FIGURE 1. Proposed mechanisms of disease responsible for the preterm parturition syndrome**

From: Romero R, Dey SK, Fisher SK. Preterm labor: one syndrome, many causes. *Science* 2014;345(6198):760.

## Vaginal progesterone, but not 17-alpha-hydroxyprogesterone caproate, has anti-inflammatory effects.

As stated above, the main strategy for the prevention of preterm birth is the administration of progestogens. Vaginal progesterone, a natural steroid hormone, is offered to women with a short cervix as it reduces the rate of preterm birth by 45% and neonatal morbidity. The other progestogen is 17-alpha-hydroxyprogesterone caproate (17-OHPC), a synthetic progestin, offered to women with a history of preterm birth.

The mechanisms whereby progestogens prevent preterm birth are unknown. We explored whether the beneficial effect of progestogens can be attributed to immunomodulation. We found that vaginal progesterone (but not 17OHP-C) (1) reduced the number of neutrophils and monocytes expressing matrix-metalloproteinase 9 (MMP-9) in the uterine cervix; (2) reduced the number of decidual macrophages and myometrial neutrophils expressing IFN $\gamma$ ; (3) raised the number of regulatory T cells in the decidua; and (4) prevented endotoxin-induced preterm birth. The results explain the difference in efficacy of vaginal progesterone vs. 17OHP-C in the prevention of preterm birth in patients with a short cervix. The study provides insight into the mechanisms whereby vaginal progesterone prevents preterm birth in women with a sonographic short cervix.

## The inflammasome in spontaneous labor at term

Transcriptomic studies have indicated that spontaneous parturition at term is characterized by an inflammatory signature. The first cytokine to be implicated in the mechanisms of normal parturition was interleukin-1 $\beta$  (IL-1 $\beta$ ), and it is now well established that this cytokine plays a central role both in term and preterm labor. However, spontaneous parturition at term represents an example of sterile inflammation, not microbial-induced inflammation. Therefore, a fundamental question is how IL-1 $\beta$  is activated in spontaneous labor at term.



We reported several studies showing that the inflammasome, a cytosolic signaling platform, participates in the activation of caspase-1 which, in turn, promotes the processing of mature IL-1 $\beta$  in the chorioamniotic membranes from women who had undergone spontaneous labor at term. These observations are consistent with our previous reports that caspase-1 is overexpressed in women with spontaneous labor at term, as well as in those with preterm labor. This is the first demonstration that inflammasome complexes are involved in physiologic parturition.

## Intra-amniotic administration of the alarmin HMGB1 induces spontaneous preterm labor and delivery.

Sterile intra-amniotic inflammation is frequently present in patients with preterm labor and intact membranes, prelabor rupture of membranes, a sonographic short cervix, and cervical insufficiency. The mechanisms responsible for sterile intra-amniotic inflammation-induced preterm delivery have not been elucidated. We proposed that alarmins released during the process of cellular stress or cell death can induce spontaneous preterm parturition. In support of this, we found that the prototypic alarmin high-mobility group box-a (HMGB1) is present in high concentrations in women with preterm labor and sterile intra-amniotic inflammation.

To determine whether an elevated amniotic fluid concentration of HMGB1 can induce preterm labor, we administered HMGB1 intra-amniotically to pregnant mice under ultrasound guidance and found that this alarmin can induce preterm labor and delivery. This is the first evidence that an alarmin can induce preterm parturition. The observations are important because a substantial number of patients with intra-amniotic inflammation do not have microbial invasion of the amniotic cavity, which can be demonstrated using cultivation and molecular microbiologic techniques. The results identify novel mechanisms of disease for preterm labor, raise questions about the mechanisms whereby alarmins can induce preterm labor, and identify potential therapeutic targets.

## Fetal intelligent navigation echocardiography (FINE)

Congenital heart disease is the leading cause of neonatal death for congenital anomalies, and the current sensitivity for the prenatal diagnosis of congenital heart disease (CHD) is the lowest. We invented a method for the visualization of standard echocardiography views from volume datasets (fetal intelligent navigation echocardiography or FINE), which is based on obtaining dataset volumes with spatio-temporal image correlation (STIC). This invention was first published in 2013 and licensed to an ultrasound company and is commercially available worldwide.

The standard obstetrical practice is to perform fetal echocardiography with 2-dimensional ultrasound. The use of FINE requires the acquisition of cardiac datasets with 4-dimensional ultrasound. Clinical application of FINE depends upon the acquisition of informative volumes and training/education of the users. We conducted two prospective studies to determine the frequency with which STIC volumes can be acquired in the second and third trimesters of pregnancy and the frequency with which the diagnostic planes recommended by professional societies (American Institute of Ultrasound in Medicine, International Society of Ultrasound in Obstetrics and Gynecology) can be obtained. In the first study, one or more STIC volumes were successfully obtained in 72.5% (150/207) of patients, of which 96.2% were considered "informative." The nine diagnostic planes were obtained in 76–100% of cases using only the "Diagnostic Plane" feature, and 98–100% when the "Virtual Intelligent Sonographer Assistance" (VIS-Assistance) was employed. Given that

FINE was invented at the PRB, we conducted a separate prospective study in a collaborative center in Italy with physicians not involved in the development of FINE, but who were trained in this method at the PRB. One or more STIC volumes were captured from 246 patients, and the diagnostic planes could be obtained in 96–100% of cases in the second and third trimesters. Collectively, these observations indicate that FINE can be used as a method of screening for CHD and is easily exported to the clinical setting.

This year, we developed a method to perform FINE using color STIC (or color FINE), an addition that is essential for the evaluation of the fetus at risk for CHD and which allows refinement in the diagnosis of abnormal fetal hearts. We have already used color FINE to improve the diagnosis of complex disorders (e.g., hypoplastic left heart, coarctation of the aorta, heterotaxia with interrupted inferior vena cava, etc.).

## Publications

1. Romero R, Nicolaides KH, Conde-Agudelo A, O'Brien JM, Cetingoz E, Da Fonseca E, Creasy GW, Hassan SS. Vaginal progesterone decreases preterm birth  $\approx$ 34 weeks of gestation in women with a singleton pregnancy and a short cervix: an updated meta-analysis including data from the OPPTIMUM study. *Ultrasound Obstet Gynecol* 2016 48:308-317
2. Furcron AE, Romero R, Mial TN, Balancio A, Panaitescu B, Hassan SS, Sahi A, Nord C, Gomez-Lopez N. Human chorionic gonadotropin has anti-inflammatory effects at the maternal-fetal interface and prevents endotoxin-induced preterm birth, but causes dystocia and fetal compromise in mice. *Biol Reprod* 2016 94:136
3. Gomez-Lopez N, Romero R, Plazyo O, Panaitescu B, Furcron AE, Miller D, Roumayah T, Flom E, Hassan SS. Intra-amniotic administration of HMGB1 induces spontaneous preterm labor and birth. *Am J Reprod Immunol* 2016 75:3-7
4. Romero R, Xu Y, Plazyo O, Chaemsaitong P, Chaiworapongsa T, Unkel R, Than NG, Chiang PJ, Dong Z, Xu Z, Tarca AL, Abrahams VM, Hassan SS, Yeo L, Gomez-Lopez N. A role for the inflammasome in spontaneous labor at term. *Am J Reprod Immunol* 2016 Epub ahead of print
5. Garcia M, Yeo L, Romero R, Haggerty D, Giardina I, Hassan SS, Chaiworapongsa T, Hernandez-Andrade E. Prospective evaluation of the fetal heart using Fetal Intelligent Navigation Echocardiography (FINE). *Ultrasound Obstet Gynecol* 2016 47:450-459

## Collaborators

- Tinnakorn Chaiworapongsa, MD, *Wayne State University School of Medicine, Detroit, MI*
- Agustin Conde-Agudelo, MD, *Wayne State University School of Medicine, Detroit, MI*
- Jean-Charles Grivel, PhD, *Section on Intercellular Interactions, NICHD, Bethesda, MD*
- Mark Haacke, PhD, *Wayne State University School of Medicine, Detroit, MI*
- Sonia Hassan, MD, *Wayne State University School of Medicine, Detroit, MI*
- Edgar Hernandez-Andrade, MD, *Wayne State University School of Medicine, Detroit, MI*
- Dan Donggeun Huh, PhD, *University of Pennsylvania, Philadelphia, PA*
- Chong-Jai Kim, MD, *University of Ulsan College of Medicine, Asan Medical Center, Seoul, Korea*
- Steven J. Korzeniewski, PhD, MSc, MA, *Wayne State University School of Medicine, Detroit, MI*
- Leonid Margolis, PhD, *Section on Intercellular Interactions, NICHD, Bethesda, MD*
- Adi L. Tarca, PhD, *Wayne State University, Detroit Medical Center, Detroit, MI*

- Moriah Thomason, PhD, *Wayne State University School of Medicine, Detroit, MI*
- Lami Yeo, MD, *Wayne State University School of Medicine, Detroit, MI*
- Bo Hyun Yoon, MD, PhD, *Seoul National University, Seoul, Korea*

## Contact

For more information, email [romeror@mail.nih.gov](mailto:romeror@mail.nih.gov) or visit <https://irp.nih.gov/pi/roberto-romero>.

## Regulation of Mammalian Intracellular Iron Metabolism and Biogenesis of Iron Sulfur Proteins

Our goal is to understand how mammals regulate intracellular and systemic iron metabolism to support processes that require iron and iron sulfur clusters. Iron-regulatory proteins 1 and 2 (IRP1 and IRP2) regulate the expression of numerous proteins of iron metabolism. In iron-depleted cells, the proteins bind to RNA stem-loops in transcripts known as iron-responsive elements (IRE). IRP binding stabilizes the mRNA that encodes the transferrin receptor and represses the translation of transcripts that contain IREs near the 5' end of the ferritin H and L chains. IRP1 is an iron-sulfur protein that functions as an aconitase in iron-replete cells. IRP2 is homologous to IRP1 but undergoes iron-dependent degradation in iron-replete cells. In mouse models, loss of IRP2 results in mild anemia, erythropoietic protoporphyria, and adult-onset neurodegeneration—all likely the result of functional iron deficiency. Biochemically and with expression arrays, we have studied the mechanisms that lead to anemia and neurodegeneration with motor neuron loss in IRP2<sup>-/-</sup> mice. We are using our mouse model of neurodegeneration to identify compounds that can prevent neurodegeneration; for example, we found that the antioxidant Tempol works by activating the latent IRE-binding activity of IRP1. Given that mitochondrial energy production is required to maintain axonal integrity and that motor neurons have the longest and most vulnerable axons, we hypothesize that mitochondrial dysfunction resulting from iron deficiency causes axonal degeneration. We discovered that deficiency in IRP1 causes polycythemia and pulmonary hypertension owing to translational derepression of hypoxia-inducible factor (HIF) 2 $\alpha$  through the IRE-IRP system. Our discovery introduces a new level of physiological regulation of erythropoiesis and provides a model for early pulmonary hypertension.

Our ongoing work on iron sulfur cluster biogenesis led to new insights into how mammalian iron sulfur clusters are synthesized and transferred to appropriate recipient proteins. Several human diseases are now known to be caused by deficiencies in the iron sulfur-cluster biogenesis machinery. We developed a treatment for the rare disease ISCU (iron-sulfur cluster assembly enzyme) myopathy. Through identification of a tri-peptide motif common to many iron sulfur recipient proteins, we developed an algorithm that facilitates discovery of previously unrecognized mammalian



**Tracey A. Rouault, MD, Head,**  
*Section on Human Iron  
Metabolism*

Wing Hang Tong, PhD, *Staff  
Scientist*

Deliang Zhang, PhD, *Staff Scientist*

Manik C. Ghosh, PhD, *Research  
Assistant*

Anshika Jain, PhD, *Visiting fellow*

Gang Liu, PhD, *Visiting fellow*

Nunziata Maio, PhD, *Visiting fellow*

Hayden Ollivierre-Wilson, *Animal  
Care Technician*

Anamika Singh, MS, *Technical  
Contract Worker*

Gregory Holmes-Hampton, PhD,  
*Postdoctoral Trainee*

Ki-Soon Kim, PhD, *Postdoctoral  
Trainee*

Gennadiy Kovtunovych, PhD,  
*Special Volunteer*

iron sulfur proteins. Our work suggests that there are hundreds of previously unrecognized mammalian iron sulfur proteins. Discovery of iron sulfur cofactors will lead to breakthroughs in several research areas involving DNA repair, ribosomal biogenesis, mRNA translation, intermediary metabolism, and regulation of growth and energy-sensing pathways that are critical for determining the fates of many cell types.

## The molecular basis for regulation of intracellular iron metabolism in mammals

In previous years, our laboratory identified and characterized the *cis* and *trans* elements mediating iron-dependent alterations in the abundance of ferritin and the transferrin receptor. IREs are RNA stem-loops found in the 5' end of ferritin mRNA and the 3' end of transferrin receptor mRNA. We cloned, expressed, and characterized two essential iron-sensing proteins, IRP1 and IRP2. IRPs bind to IREs when iron levels are depleted, resulting in either inhibition of translation of ferritin mRNA and of other transcripts that contain an IRE in the 5'-untranslated regions (UTR) or stabilization of the transferrin receptor mRNA and possibly other transcripts that contain IREs in the 3' UTR. The IRE-binding activity of IRP1 depends on the presence of an iron-sulfur cluster (see "Mammalian iron-sulfur cluster biogenesis" below). IRP2 also binds to IREs in iron-depleted cells but, unlike IRP1, is degraded in iron-replete cells, where it is selectively ubiquitinated and then degraded by the proteasome.

To approach questions about the physiology of iron metabolism, we generated loss-of-function mutations of IRP1 and IRP2 in mice through homologous recombination in embryonic cell lines. In the absence of provocative stimuli, we initially observed no abnormalities in iron metabolism associated with loss of IRP1 function. IRP2<sup>-/-</sup> mice develop a progressive neurologic syndrome characterized by gait abnormalities and axonal degeneration. Ferritin overexpression occurs in affected neurons and in protrusions of oligodendrocytes into the space created by axonal degeneration. IRP2<sup>-/-</sup> animals develop iron-insufficiency anemia and erythropoietic protoporphyria. In animals that lack IRP1, IRP2 compensates for loss of IRP1's regulatory activity in most cell types, but we discovered several cell types and accompanying phenotypes in which IRP2 expression cannot be sufficiently increased to compensate. Animals that lack both IRP1 and IRP2 die as early embryos. The adult-onset neurodegeneration of adult IRP2<sup>-/-</sup> mice is exacerbated when one copy of IRP1 is also deleted. IRP2<sup>-/-</sup> mice offer a unique example of spontaneous adult-onset, slowly progressive neurodegeneration; analyses of gene expression and iron status at various stages of disease are ongoing. Dietary supplementation with the stable nitroxide Tempol prevents neurodegeneration; the treatment appears to work by recruiting the IRE-binding activity of IRP1. We found that motor neurons were the most adversely affected neurons in IRP2<sup>-/-</sup> mice and that neuronal degeneration accounted for the gait abnormalities.

We discovered a form of the iron exporter ferroportin that lacks the IRE at its 5' end that is important in permitting iron to cross the duodenal mucosa in iron-deficient animals and in preventing developing erythroid cells from retaining high amounts of iron in iron-deficient animals. Our findings explain why microcytic anemia is usually the first physiological manifestation of iron deficiency in humans. In addition, we recently discovered that loss of IRP1 causes polycythemia and pulmonary hypertension through derepression of hypoxia-inducible factor 2a (HIF2a) translation in renal interstitial through the IRE-IRP system.

We also elucidated the pathophysiology of intravascular hemolysis and hyposplenism in animals that lack heme oxygenase 1. Their tissue macrophages die because they cannot metabolize heme after phagocytosis



Members of the Section on Human Iron Metabolism

of red cells. To mitigate or reverse disease, we performed bone marrow transplants from wild-type animals to supply animals with functional macrophages; the bone marrow transplants were successful. We thus aim to correct the heme oxygenase defect in hematopoietic stem cells, using CRISPR technology, and to fully correct heme-oxygenase deficiency in the mice, experiments that would pave the way to treating heme oxygenase 1-deficient human patients, an under-diagnosed rare human disease.

## Mammalian iron-sulfur cluster biogenesis

Our goals in studying mammalian iron-sulfur biogenesis are to understand how iron-sulfur prosthetic groups are assembled and delivered to target proteins in the various compartments of mammalian cells, including mitochondria, cytosol, and nucleus. In addition, we seek to understand the role of iron-sulfur cluster assembly in the regulation of mitochondrial iron homeostasis and the pathogenesis of diseases such as Friedreich's ataxia and sideroblastic anemia, which are both characterized by incorrect regulation of mitochondrial iron homeostasis.

IRP1 is an iron-sulfur protein related to mitochondrial aconitase, which is a citric acid cycle enzyme that functions as a cytosolic aconitase in iron-replete cells. Regulation of RNA-binding activity of IRP1 involves a transition from a form of IRP1 in which a [4Fe-4S] cluster is bound to a form that loses both iron and aconitase activity. The [4Fe-4S]-containing protein does not bind to IREs. Controlled degradation of the iron-sulfur cluster and mutagenesis reveal that the physiologically relevant form of the RNA-binding protein in iron-depleted cells is an apoprotein. The status of the cluster appears to determine whether IRP1 binds to RNA.

We identified numerous mammalian enzymes of iron-sulfur cluster assembly that are homologous to those encoded by the *nifs*, *iscu*, and *nifu* genes, which are implicated in bacterial iron-sulfur cluster assembly, and we observed that mutations in several iron-sulfur cluster biogenesis proteins cause disease. Loss of frataxin, a protein that promotes the biosynthesis of heme and assembly and repair of iron-sulfur clusters by delivering Fe<sup>2+</sup> to proteins involved in these pathways, causes Friedreich's ataxia, which is characterized by progressive compromise of balance and cardiac function. In a cohort of patients of Swedish descent, we found that loss of ISCU causes skeletal myopathy. To explain the tissue specificity of ISCU myopathy, we studied myoblasts and other patient-derived tissue samples and cell lines. We discovered that many factors contribute to insufficiency of the iron-sulfur scaffold protein ISCU in skeletal muscle, including more pronounced abnormal splicing and unusual sensitivity of ISCU to degradation upon exposure to oxidative stress. Thus, oxidative stress may impair the ability of tissues to repair damaged iron-sulfur clusters by directly damaging a key component of the biogenesis machinery. A splicing abnormality of glutaredoxin 5 was found to be associated with sideroblastic anemia in one patient. In the affected tissues, mitochondrial iron overload is a feature common to all three diseases.

In collaborative work, we discovered that mutations of two iron-sulfur cluster assembly proteins, NFU1 and BOLA3, are required for correct lipoylation of many critical metabolic complexes, including pyruvate dehydrogenase. We identified a tripeptide motif, LYR, in apoproteins that are recipients of nascent iron-sulfur clusters. The co-chaperone HSC20 binds to HSPA9, its partner HSP70-type chaperone, and that chaperone complex binds to ISCU bearing a nascent iron-sulfur cluster and to iron sulfur cluster recipient proteins. We identified several direct iron-sulfur-recipient proteins in a yeast two-hybrid assay using HSC20 as bait. By studying one known iron-sulfur recipient, succinate dehydrogenase subunit B (SDHB), we discovered that several LYR motifs of the SDHB primary sequence engage the iron-sulfur transfer apparatus by binding to the C-terminus of HSC20, facilitating delivery of the three iron-sulfur clusters of succinate dehydrogenase subunit B. We further discovered that the assembly factor SDHAF1 also engages the iron sulfur cluster transfer complex to facilitate transfer of iron sulfur clusters to SDHB. The discovery of the LYR motif will aid in identification of unknown iron-sulfur proteins, which are likely much more common in mammalian cells than has been previously appreciated.

Using expression arrays, we analyzed mechanisms by which compromised mitochondrial iron-sulfur cluster biogenesis leads to mitochondrial iron overload. We postulate that regulation of mitochondrial iron homeostasis depends on intact synthesis of an iron-sulfur cluster-regulatory protein. Once this pathway is better understood, insights may lead to treatments for several rare diseases.

We discovered that anti-sense therapy would likely work as a treatment for ISCU myopathy patients, as we were able to correct the causal splicing defect in patient myoblasts using stable anti-sense RNAs that were manufactured by high-quality techniques suitable for use in patients.

## Publications

1. Rouault TA. Mammalian iron-sulphur proteins: novel insights into biogenesis and function. *Nat Rev Mol Cell Biol* 2015 16:45-55.
2. Ghosh MC, Zhang L, Rouault TA. Iron misregulation and neurodegenerative disease in mouse models that lack iron regulatory proteins. *Neurobiol Dis* 2015 81:66-75.

3. Rouault TA. Iron-sulfur proteins hiding in plain sight. *Nat Chem Biol* 2015 11:442-445.
4. Maio N, Ghezzi D, Verrigni D, Rizza T, Bertini E, Martinelli D, Zeviani M, Singh A, Carrozzo R, Rouault TA. Disease-causing SDHAF1 mutations impair transfer of Fe-S clusters to SDHB. *Cell Metab* 2016 23:292-302.
5. Maio N and Rouault TA. Mammalian Fe-S proteins: definition of a consensus motif recognized by the co-chaperone HSC20. *Metallomics* 2016 8:1032-1046.

## Collaborators

- Shuling Guo, PhD, *IONIS Pharmaceuticals, Carlsbad, CA*
- Ronald Haller, MD, *University of Texas Southwestern Medical Center, Dallas, TX*
- W. Marston Linehan, MD, *Urologic Oncology Branch, Center for Cancer Research, NCI, Bethesda, MD*
- Brett Monia, PhD, *IONIS Pharmaceuticals, Carlsbad, CA*
- John F. Tisdale, MD, *Molecular and Clinical Hematology Branch, NIDDK, Bethesda, MD*

## Contact

For more information, email [trou@helix.nih.gov](mailto:trou@helix.nih.gov) or visit <https://irp.nih.gov/pi/tracey-rouault>.



## Control of Ectodermal Development in Vertebrate Embryos

The laboratory focuses on mechanisms regulating the differentiation of cranial neural crest cells, which give rise to the bone and cartilage of the vertebrate jaw, neuro-cranium, and other structures of the face and head. Our approach is to manipulate transcriptional control mechanisms in the intact zebrafish embryo using gain- and loss-of-function strategies, with the aim of identifying the regulatory networks that control craniofacial development. Disruption of these developmental programs is the most common source of birth defects in humans, the detection, prevention, and treatment of which is a central aspect of NICHD's mission. Equally important, understanding the regulation of gene expression in this complex embryonic tissue represents a challenging and fascinating problem in basic molecular and developmental biology.

The origin of the lab's neural crest research was our discovery in 2003 that, in the frog *Xenopus*, the transcription factor TFAP2a is both necessary and sufficient to trigger the conversion of cells at the neural plate border from neural to neural-crest identity. We went on to show that TFAP2a mediates the transcriptional response to bone morphogenetic protein (BMP) signaling in neural-crest induction. We also carried out pioneering research on the homeodomain factor Dlx3, performing the first mouse knock-out of the gene encoding this factor and demonstrating the factor's function in the development of mammalian epidermis and placenta. We were also the first to demonstrate the phylogenetic conservation of *Dlx* gene-regulatory elements by transferring *Xenopus Dlx* enhancers into the mouse genome, showing that enhancers were conserved between these two distantly related vertebrates, including enhancers active in tissues, such as hair follicle and mammary gland, that have no counterpart in amphibians. We also investigated the role of Dlx3 and other members of this family in establishing the boundary of the neural crest in *Xenopus*. The Dlx family remains our current focus of research.

### *Dlx* gene function in cranial neural crest development

In the previous year we focused on loss-of-function experiments with the Dlx family of homeodomain transcription factors. Following reports from numerous labs, including our own, indicating that



**Thomas D. Sargent, PhD,**  
*Head, Section on Vertebrate  
Development*

Neal MacDonald, AB,  
*Postbaccalaureate Fellow*

Allisan Aquilina-Beck, BA,  
*Technician (part time)*

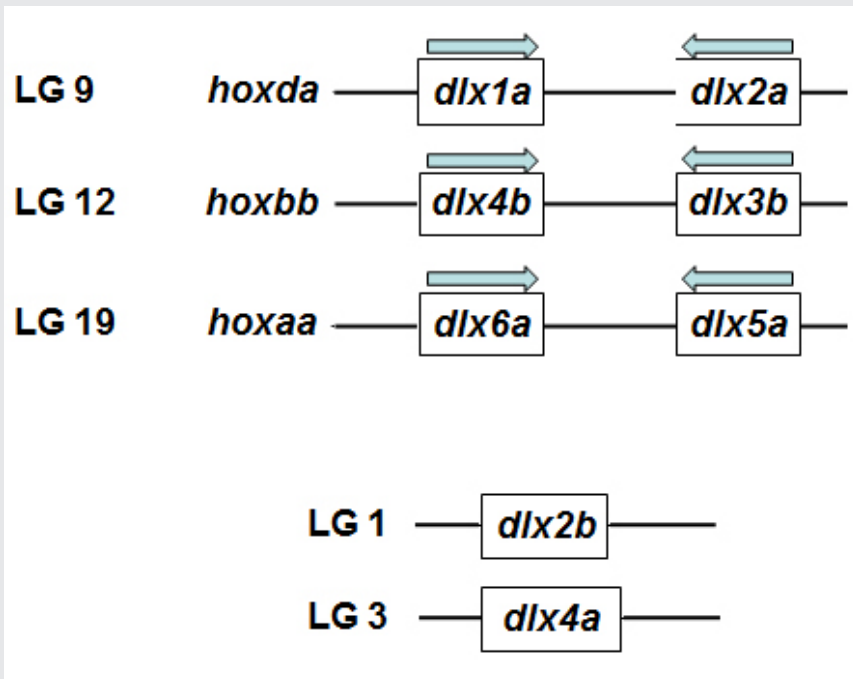

**FIGURE 1. Genomic organization of *dlx* genes**

Zebrafish *dlx* genes *dlx1a*, *dlx2a*, *dlx3b*, *dlx4b*, *dlx5a*, and *dlx6a* are organized into three pairs of convergently transcribed loci with about 10kb of intergenic 3' sequence. Each pair is linked to one *hox* gene cluster, mirroring the pattern found in other vertebrates such as human. The remaining two, *dlx2b* and *dlx4a*, are located at unlinked positions in the genome. Drawing is not to scale.

“knock down” analysis of gene function using antisense morpholinos frequently yielded results that were at variance with chromosomally based gene inactivation strategies, we set out to apply the CRISPR/Cas targeting approach to the *dlx* family in zebrafish. The objective of this project is to identify and characterize embryonic craniofacial phenotypes resulting from loss of individual *dlx* genes or combinations thereof. The targeting is being conducted in a line of fish carrying a GFP fluorescent marker expressed in cranial cartilage, enabling high-resolution imaging of affected tissues using confocal microscopy. So far we have identified INDEL (insertion and deletion) mutations that disrupt protein function of all six of the canonical *dlx* genes (i.e., *dlx1-6*), and we are in the process of targeting the two “extra” zebrafish *Dlx* loci (*dlx2b* and *dlx4a*). By in-crossing heterozygous carriers, we generated null embryos for all six individual *dlx* loci, as well as double-nulls for the linked pairs of genes (*dlx1a+dlx2a*, *dlx3b+dlx4b*, and *dlx5a+dlx6a*). In most cases, we observed little if any effect on early development. In particular, craniofacial cartilage formation was not affected. The exceptions were *dlx2a* and *dlx1a/dlx2a* double mutants, which showed abnormal jaw development in a portion of null embryos (i.e., incomplete penetrance). Most surprising is the observation that the *dlx5a/dlx6a* double-mutant embryos have apparently normal craniofacial development; equivalent mutations in the mouse result in massive defects in cranial morphology and limb formation. Our general conclusion is that, in zebrafish, *dlx* genes are much less critical for craniofacial or limb development (fins are also unaffected) than in the mouse. The finding has important evolutionary implications and is also relevant to the use of zebrafish as a general model system for functional analysis of genes found associated with disease in humans.

## Publications

1. Law SHW, Sargent TD. The serine-threonine protein kinase PAK4 is dispensable in zebrafish: identification of a morpholino-generated pseudophenotype. *PLoS One* 2014 E100268.

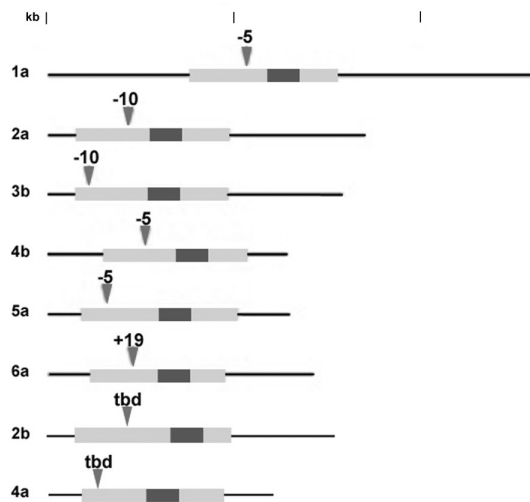
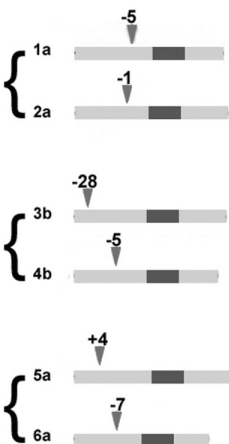
**A****B**

**FIGURE 2. Summary of INDEL mutations in zebrafish *dlx* genes**

A) The mRNAs of individual *dlx* genes are shown, with the open reading frames (ORFs) indicated in light gray and the homeodomains in dark gray. The location and size of deletions (-) or insertions (+) are indicated by the arrow heads. INDELS in *dlx2b* and *dlx4a* have not been fully characterized; tbd, to be determined.

B) Summary of the paired null mutations in linked loci (only ORFs are shown).

## Collaborators

- Maria Morasso, PhD, *Laboratory of Skin Biology, NIAMS, Bethesda, MD*

## Contact

For more information, email [sargentt@mail.nih.gov](mailto:sargentt@mail.nih.gov) or visit <http://sargentlab.nichd.nih.gov>.

## Mechanisms of Synapse Assembly, Maturation, and Growth during Development

The purpose of our research is to understand the mechanisms of synapse development and homeostasis. The chemical synapse is the fundamental communication unit, connecting neurons in the nervous system to one another and to non-neuronal cells, and is designed to mediate rapid and efficient transmission of signals across the synaptic cleft. Such transmission forms the basis of the biological computations that underlie and enable our complex behavior. Crucial to this function is the ability of a synapse to change its properties, so that it can optimize its activity and adapt to the status of the cells engaged in communication and/or to the larger network comprising them. Consequently, synapse development is a highly orchestrated process coordinated by intercellular communication between the pre- and postsynaptic compartments and by neuronal activity itself. Our long-term goal is to elucidate the molecular mechanisms, particularly those involving cell-cell communication, that regulate formation of functional synapses during development and that fine-tune them during plasticity and homeostasis. We focus on three key processes in synaptogenesis: (1) trafficking of components to the proper site, (2) organizing those components to build synaptic structures, and (3) maturation and homeostasis of the synapse to optimize its activity. We address the molecular mechanisms underlying these processes using a comprehensive set of approaches that include genetics, biochemistry, molecular biology, super-resolution imaging, and electrophysiology recordings in live animals and reconstituted systems.

### *Drosophila* Neto, an obligatory auxiliary subunit for neuromuscular junction (NMJ) glutamate receptors

The first step in the assembly of synapses involves recruitment of synaptic components at the proper site. Prior to the motor neuron arrival, the ionotropic glutamate receptors (iGluRs) form small, nascent clusters on the muscle, which are distributed in the vicinity of future synaptic sites. Neuron arrival at its target muscle triggers formation of large synaptic iGluRs aggregates and promotes expression of more iGluRs to permit synapse maturation and growth. The iGluR clusters interact with the local cytoskeleton and other synaptic structures to maintain local density. This involves solving



**Mihaela Serpe, PhD, Head, Unit on Cellular Communication**

Simon Haering, PhD, *Visiting Fellow*

Tae Hee Han, PhD, *Visiting Fellow*

Cathy Ramos, PhD, *Visiting Fellow*

Qi Wang, PhD, *Visiting Fellow*

Grace Kim, BS, *Postbaccalaureate Fellow*

Peter Nguyen, *Biological Laboratory Technician*

two fundamental problems common to all chemical synapses: (1) trafficking the components to the proper site, and (2) organizing those components to build synaptic structures. Recent advances, particularly from vertebrate iGluR biology, reveal that the solution to these problems is completely dependent on the activity of a rich array of auxiliary subunits that associate with the receptors. These highly diverse transmembrane proteins associate with iGluRs at all stages of the receptor life-cycle and mediate the delivery of receptors to the cell surface, their distribution, synaptic recruitment, association with various postsynaptic density (PSD) scaffolds, and importantly, their channel properties. As they are assembled from different subunits, iGluRs have strikingly varied biophysical properties; their association with different auxiliary subunits increases this diversity even further. In flies as in humans, synapse strength and plasticity are determined by the interplay between different iGluR subtypes. At the fly NMJ, type-A and type-B iGluRs consist of four different subunits: either GluRIIA or -IIB, plus -IIC, -IID and -IIE. Various mechanisms regulating the extent of type-A and type-B receptor accumulation at synaptic sites have been described but the molecular mechanisms for the initial localization and clustering of receptors at synaptic sites had remained a mystery.

We recently discovered that an obligatory auxiliary protein, Neto, is absolutely required for the iGluRs clustering and NMJ functionality. To date, Neto is the only auxiliary protein characterized in *Drosophila*. Neto belongs to a family of highly conserved auxiliary proteins that regulate glutamatergic synapses, the major excitatory synapses in our brain. Using Neto as our entry point, we set out to elucidate the molecular mechanisms underlying the synaptic recruitment of iGluRs and their incorporation in stable neural clusters. Given that Neto does not have any catalytic activities, we hypothesized that Neto controls synapse development by interacting with iGluRs and/or with other proteins critical for synapse development. Our investigations uncovered essential roles for Neto during synapse development and strongly support the notion that trafficking of both iGluR subtypes on the muscle membrane, their synaptic recruitment and stabilization, and their function are tightly regulated by Neto. We report that Neto (a) engages in extracellular interactions that stabilize iGluRs at synaptic sites and trigger postsynaptic differentiation, (b) mediates intracellular interactions that anchor postsynaptic density components and sculpt iGluRs' postsynaptic composition, and (c) modulates iGluRs' function but not their assembly or surface delivery. More specifically, we found that Neto activities are regulated by Furin-mediated limited proteolysis, which removes an inhibitory prodomain. When the prodomain cleavage is blocked, Neto engages the iGluRs *in vivo*, but cannot mediate their stable incorporation/clustering at synaptic sites and fails to initiate postsynaptic differentiation. We discovered new Neto isoforms with isoform-specific roles in the recruitment of specific postsynaptic density proteins and in the selective stabilization of synaptic iGluRs. In collaboration with Mark Mayer, we reported the first functional reconstitution of *Drosophila* NMJ iGluRs in *Xenopus* oocytes and the first crystal structure for an insect iGluR, and we used the *Xenopus* system to examine the subunit dependence and function of these receptors. We found that, independently of Neto, four separate iGluR subunits are required for surface expression; however, Neto increases the glutamate-activated currents by several orders of magnitude. These results, which are reported in a landmark paper (Reference 5), will be key to resolving the molecular basis of the compound phenotypes observed at mutant synapses.

More recently, towards analysis of iGluRs' gating properties, we expanded our microscopy and electrophysiology toolboxes to include super-resolution imaging and fast agonist perfusion. This will allow us to parse the role of specific Neto domains and/or Neto-interacting proteins onto iGluRs' function vs. cellular trafficking. Using this methodology, we have already contributed to papers that describe new characteristics for vertebrate and insect iGluRs. A central question is how the highly conserved Neto and/or other auxiliary

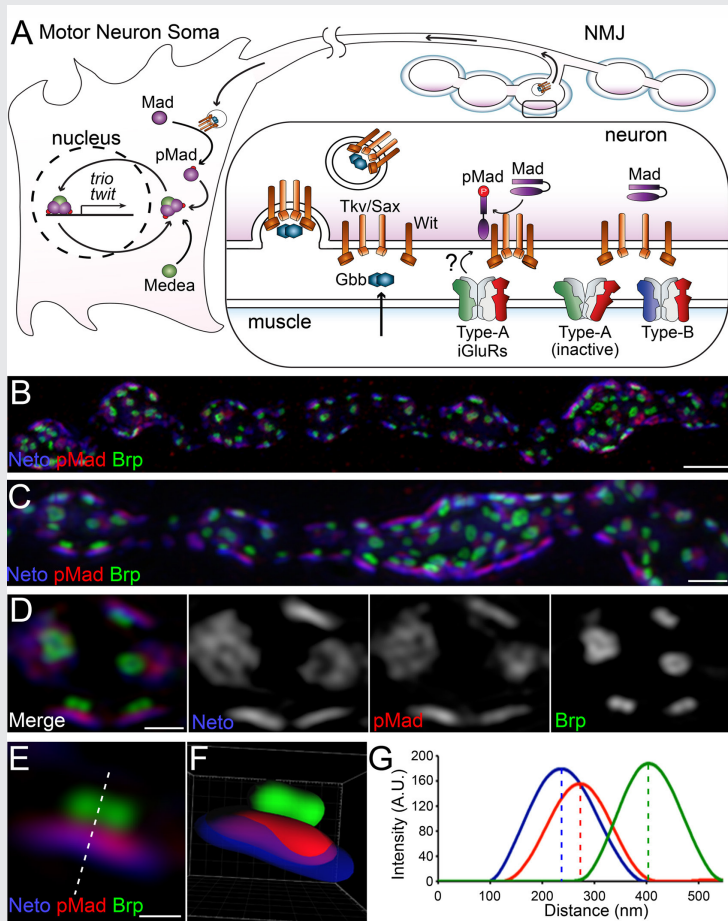

**FIGURE 1. Synaptic pMad localizes at the active zone.**

(A) Diagram of BMP signaling complexes that control the accumulation of nuclear and synaptic pMad. Extracellular BMPs bind to a complex composed of Type I and Type II BMP receptors (BMPRs). The BMP/BMPR complexes are endocytosed and transported to the neuron soma, where they phosphorylate Mad and allow for pMad's translocation to and accumulation in the motor neuron nuclei. Synaptic pMad mirrors the active postsynaptic GluRIIA and likely reflects local accumulation of BMP/BMPR complexes at synaptic terminals.

(B-D) 3D-SIM images of NMJ12 boutons from third instar larvae labeled for Brp (green), pMad (red), and Neto (blue). SIM z stack maximum projections are shown in panels A and B, and a single z plane is shown in panel C.

(E) High magnification view of a single synapse profile (from panel C). The line indicates the position used for the linescan plotted in panel F.

(F) Side view of a surface-rendered volume of the synapse shown in panel D.

(G) Intensity profile of Neto, pMad, and Brp signal along the line drawn in panel E. Linescans such as this were performed across many synapses to measure the distance of pMad and Neto from Brp.

subunits modulate the function of highly diversified iGluRs.

## A novel, noncanonical BMP pathway modulates synapse maturation at the *Drosophila* neuromuscular junction

Synaptic activity and synapse development are intimately linked, but our understanding of the coupling mechanisms remains limited. Anterograde and retrograde signals together with trans-synaptic complexes enable intercellular communication. How synapse activity status is monitored and relayed across the synaptic cleft remains poorly understood. The *Drosophila* NMJ is a powerful genetic system to study synapse development. BMP (bone morphogenetic protein) signaling modulates NMJ growth and neurotransmitter release, via a canonical pathway that is dependent on the transcription factor Smad, and synapse stability, via a noncanonical, Smad-independent pathway. Both pathways are triggered by Glass-bottom boat (Gbb), a BMP7 homolog, which binds to the presynaptic bone morphogenetic protein receptor II (BMPRII) Wishful thinking (Wit) and to the BMPRIIs Thickveins (Tkv) and Saxophone (Sax). The canonical pathway activates presynaptic transcriptional programs with distinct roles in the structural and functional development of the NMJ. In the noncanonical pathway, Wit/BMPRII signal through LIM domain kinase 1 (LIMK1) to regulate actin dynamics and thus synapse stability.

We recently discovered that phosphorylated Smad (pMad), the BMP pathway effector, accumulates at synaptic terminals in response to specific glutamate receptor subtypes, the type-A receptors. pMad accumulates at synaptic terminals at the onset of synaptogenesis and mirrors postsynaptic glutamate receptor GluRIIA throughout the NMJ development. Moreover, synaptic pMad follows the activity but not the net levels of synaptic type-A receptors, suggesting that pMad functions as a sensor for synapse activity. In collaboration with Jennifer Lippincott-Schwartz's laboratory, we used 3D structured illumination microscopy (3D-SIM) to demonstrate that pMad accumulates at the active zone (Figure 1). Our data show that synaptic pMad is distributed into discs of irregular shapes, in the close proximity to the presynaptic membrane. At *Drosophila* NMJ synapses, the sites of neurotransmitter release are marked by presynaptic specializations called T-bars, where Bruchpilot (Brp), the fly homolog of the vertebrate active-zone protein ELKS, accumulates. Opposite to the T-bars, the postsynaptic densities (PSDs) comprise a myriad of proteins, including Neto, that concentrate and stabilize the iGluRs. The pMad-positive signals localize between the Brp-marked T-bars and the Neto-labeled PSDs, closer to Neto.

Using genetic epistasis, histology, and electrophysiology approaches, we found that synaptic pMad is generated in the presynaptic compartment (the motor neuron) via a novel BMP signaling pathway that is genetically distinguishable from both the canonical BMP signaling and the Wit/LIMK1 noncanonical pathway. The novel pathway does not require Gbb, but depends on presynaptic Wit and Sax and postsynaptic type-A receptors. Synaptic pMad is coordinated with BMP's role in the transcriptional control of target genes by shared pathway components but plays no role in the regulation of NMJ growth. Instead, we found that selective disruption of presynaptic pMad accumulation reduces postsynaptic GluRIIA levels, revealing a positive feedback loop that appears to function to stabilize active type-A receptors at synaptic sites. The type-A receptors are the first to arrive at a nascent synapse, whereas type-B receptors mark mature synapses. Therefore, the novel BMP signaling modality appears to be involved in sculpting synapse composition and maturation.

It is important to recognize that all these BMP signaling modalities are coordinated by shared, limited components, in particular the BMP receptors, which are tightly regulated at transcriptional, translational, and post-translational levels. The canonical BMP signaling pathway requires endocytosis of the BMP/BMPR signaling complexes and their retrograde transport to the motor neuron soma, whereas the noncanonical pathways rely on BMP/BMPR complexes' functioning at synaptic terminals. Given that the pathways share limited pools of BMPRs, the motor neurons must balance the partitioning of BMPRs among different BMP signaling modalities. Consequently, BMP signaling may monitor synapse activity and coordinate it with synapse growth and maturation.

## Publications

1. Sulkowski M, Han TH, Ott C, Wang Q, Verhenyer EM, Brown K, Lippincott-Schwartz J, Serpe M. A novel, noncanonical BMP pathway modulates synapse maturation at the *Drosophila* neuromuscular junction. *PLoS Genetics* 2016 12:e1005810.
2. Meyerson JR, Chittori S, Merk A, Rao P, Han TH, Serpe M, Mayer ML, Subramaniam S. Structural basis of kainate subtype glutamate receptor desensitization. *Nature* 2016 567-571.
3. Kim Y-J, Igesuorobo O, Ramos CI, Bao H, Zhang B, Serpe M. Prodomain removal enables Neto to stabilize glutamate receptors at *Drosophila* neuromuscular junction. *PLoS Genet* 2015 11:e1004988.

4. Ramos CI, Igiesuorobo O, Wang Q, Serpe M. Neto-mediated intracellular interactions shape postsynaptic composition at the *Drosophila* neuromuscular junction. *PLoS Genet* 2015 11:e1005191
5. Han TH, Poorva D, Mayer ML, Serpe M. Functional reconstitution of *Drosophila* NMJ glutamate receptors. *Proc Natl Acad Sci USA* 2015 112:6182-6187

## Collaborators

- Chi-Hon Lee, MD, PhD, *Section on Neuronal Connectivity, NICHD, Bethesda, MD*
- Jennifer Lippincott-Schwartz, PhD, *Section on Organelle Biology, NICHD, Bethesda, MD*
- Mark Mayer, PhD, *Laboratory of Cellular and Molecular Neurophysiology, NICHD, Bethesda, MD*
- Sriram Subramaniam, PhD, *Laboratory of Cell Biology, Center for Cancer Research, NCI, Bethesda, MD*

## Contact

For more information, email [mihaela.serpe@nih.gov](mailto:mihaela.serpe@nih.gov) or visit <http://ucc.nichd.nih.gov>.



## Thyroid Hormone Regulation of Vertebrate Postembryonic Development

This laboratory investigates the molecular mechanisms of thyroid hormone (TH) function during postembryonic development. The main model is the metamorphosis of *Xenopus laevis* and *X. tropicalis*, two highly related species that offer unique but complementary advantages. The control of this developmental process by TH offers a paradigm to study gene function in postembryonic organ development. During metamorphosis, different organs undergo vastly different changes. Some, like the tail, undergo complete resorption, while others, such as the limb, are developed *de novo*. The majority of larval organs persist through metamorphosis but are dramatically remodeled to function in a frog. For example, the tadpole intestine is a simple tubular structure consisting primarily of a single layer of larval epithelial cells. During metamorphosis, it is transformed into an organ with a multiply folded adult epithelium surrounded by elaborate connective tissue and muscles through specific larval epithelial cell death and *de novo* development of adult epithelial stem cells followed by their proliferation and differentiation. The wealth of knowledge from past research and the ability to manipulate amphibian metamorphosis both *in vivo* by using genetic approaches or hormone treatment of whole animals, and *in vitro* in organ cultures offer an excellent opportunity both to study the developmental function of TH receptors (TRs) and the underlying mechanisms *in vivo* and to identify and functionally characterize genes critical for organogenesis, particularly for the formation of the adult organ-specific stem cells, during postembryonic development in vertebrates. A major recent focus has been to make use of the TALEN and CRISPR/Cas9 technologies (References 1, 2) to knockdown or knockout the endogenous genes for functional analyses. Our past studies also revealed likely conserved mechanisms in adult intestinal stem cell development in vertebrates, which prompted us to adapt the mouse model to complement the amphibian system.

### TR controls metamorphic timing and rate but is not essential for metamorphosis.

We developed a transcription activator-like effector nuclease (TALEN) that could mutate the *TRa* gene in *X. tropicalis* with over 90% efficiency by injecting TALEN mRNAs into fertilized eggs, making it possible to analyze the role of TRa in the resulting F0 animals. Using



Yun-Bo Shi, PhD, Head, Section on Molecular Morphogenesis

Liezhen Fu, PhD, Staff Scientist

Morihiro Okada, PhD, Visiting Fellow

Julia Rodiger, PhD, Visiting Fellow

Yuki Shibata, PhD, Visiting Fellow

Luan Wen, PhD, Visiting Fellow

Nga Luu, MS, Biologist

Lingyu Bao, MS, Graduate Student

FIGURE 1. Schematics showing the dual effects of TR $\alpha$  knockdown on premetamorphic development in *Xenopus tropicalis*

TR $\alpha$  knockdown has little effect on embryogenesis, and the resulting tadpoles are normal by feeding stage (stage 45). Once feeding begins, the animals grow differently: the knockdown ones grow faster and are thus larger than wild-type siblings of the same age (in days) (compare the vertical axis values of the lines for the knockdown and wild-type animals at any given position along the horizontal axis between stages 45 and 54). The knockdown animals also have faster development, reaching developmentally more advanced stages than do wild-type siblings of the same age (in days). Thus, the knockdown animals reach stage 54, the onset of metamorphosis, at a younger age (see the horizontal axis locations for the upper end of the lines). Interestingly, when animals at stage 54 are compared, the wild-type ones are larger than the knockdown siblings, even though the latter grow faster. This is because the wild-type animals take longer to reach metamorphosis (stage 54). The extra growth time needed to reach stage 54 enables the wild-type to catch up and surpass the knockdowns in size. The results indicate that the effects of TR on growth and development are not dependent on each other (as otherwise, the size of the wild-type and knockdown animals at stage 54 would be identical).

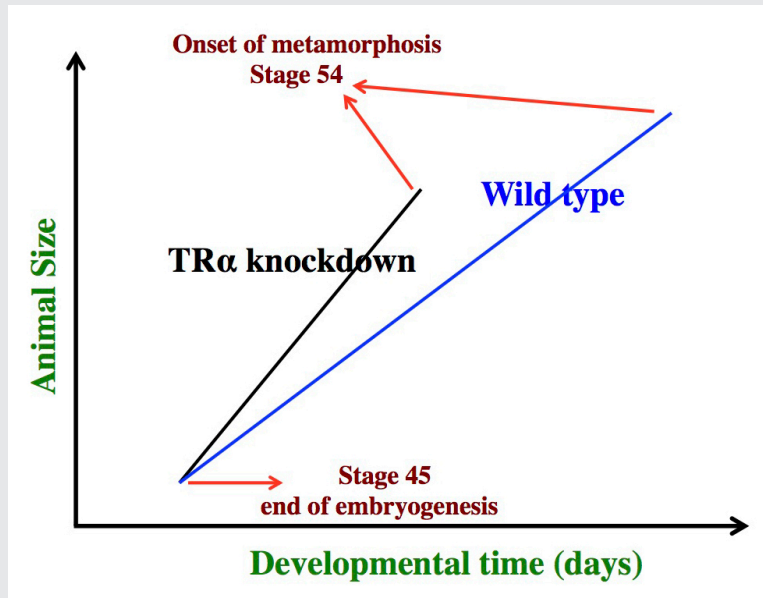

the F0 animals, we provided evidence to support a dual function model for TR $\alpha$  during frog development, i.e., unliganded TR $\alpha$  represses gene expression and prevents precocious metamorphosis while liganded TR $\alpha$  activates target gene transcription and promotes metamorphosis (Reference 1). More recently, we used the F0 animals to generate animals with total knockout of the *TR $\alpha$*  gene. Surprisingly, we observed that total knockout of TR $\alpha$  did not block metamorphosis, suggesting that the second TR gene, *TR $\beta$* , was able to mediate the metamorphic effects of TH. While TR $\alpha$  is not essential for metamorphosis, *TR $\alpha$*  knockout accelerated animal development, with the knockout animals reaching the onset of metamorphosis earlier. On the other hand, they were resistant to exogenous TH treatment and had slower rate of natural metamorphosis. The findings are consistent with our earlier studies with the TR $\alpha$  knockdown animals. Thus, our studies directly demonstrated a critical role of endogenous TR $\alpha$  both in mediating the metamorphic effect of TH during metamorphosis and in preventing precocious initiation of metamorphosis when TH is absent. Additionally, our knockout animal studies confirmed our initial novel observation on the growth of TR $\alpha$  knockdown animals, i.e., that TR $\alpha$  knockout enhanced tadpole growth in premetamorphic tadpoles, in part by enhancing the expression of the two growth hormone genes in *Xenopus*.

## The histone methyltransferase Dot1L is a coactivator for TR and plays an essential role in premetamorphic tadpole growth.

We earlier identified Dot1L, the only histone methyl transferase (HMT) capable of methylating histone

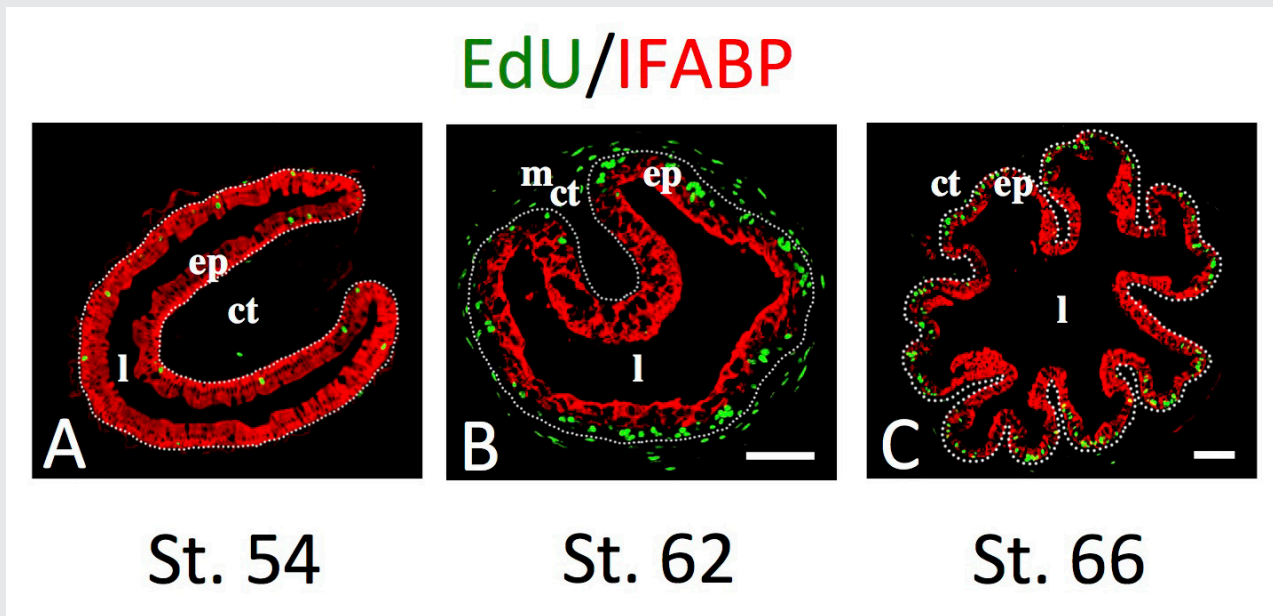

**FIGURE 2.** Intestinal metamorphosis involves the formation of clusters of proliferating, undifferentiated epithelial cells at the climax.

Tadpoles at premetamorphic stage 54 (A), climax (B, stage 62), and end of metamorphosis (C, stage 66) were injected with 5-ethynyl-2'-deoxyuridine (EdU) one hour before being sacrificed. Cross-sections of the intestine from the resulting tadpoles were double-stained by EdU labeling of newly synthesized DNA and by immunohistochemistry of IFABP (intestinal fatty acid binding protein), a marker for differentiated epithelial cells. The dotted lines depict the epithelium-mesenchyme boundary. Note that there were few EdU-labeled proliferating cells in the epithelium and that they expressed IFABP at premetamorphosis (A) and increased in the form of clustered cells (proliferating adult stem cells) that lacked IFABP at the climax of metamorphosis (B). At the end of metamorphosis, EdU-labeled proliferating cells were localized mainly in the troughs of the epithelial folds where IFABP expression was low (C). ep, epithelium; ct, connective tissue; m, muscles; l, lumen. See Reference 5 for more details.

H3K79 *in vitro*, as a direct target gene of TR. Interestingly, the level of H3K79 methylation is strongly enhanced by TR at TR target genes, suggesting that Dot1L is upregulated by TR and in turn functions as a TR coactivator. Indeed, in cell culture assays and in the frog oocyte transcription system, we showed that overexpression of Dot1L enhanced gene transcription by TR in the presence of TH. More importantly, transgenic overexpression of Dot1L in tadpoles also enhances gene activation of endogenous TR target genes by TH. To investigate the role of endogenous Dot1L, we generated a Dot1L-specific TALEN that was extremely efficient in mutating Dot1L when expressed in fertilized eggs of *X. tropicalis*, creating animals with almost no Dot1L and little H3K79 methylation. We observed that Dot1L knockdown had no apparent effect on embryogenesis (Reference 3). On the other hand, it severely retarded tadpole growth and led to tadpole lethality before metamorphosis (Reference 3). Furthermore, the expression of endogenous TR target genes was also reduced. The findings suggest that Dot1L and H3K79 methylation together play an important role in tadpole growth and development prior to metamorphosis and that Dot1L functions at least in part as a coactivator for TR.

## The amidohydrolase domain-containing 1 gene is directly activated by TH and likely plays a role in the formation of adult intestinal stem cells during *Xenopus* metamorphosis.

TH-dependent anuran metamorphosis resembles postembryonic development in mammals, the period around birth when plasma TH levels peak. In particular, the remodeling of the intestine during metamorphosis mimics neonatal intestinal maturation in mammals when the adult intestinal epithelial self-renewing system is established. We have been using intestinal metamorphosis to investigate how organ-specific adult stem cells are formed during vertebrate development. Early studies in *X. laevis* showed that the process involves complete degeneration of the larval epithelium and *de novo* formation of adult stem cells. A tissue-specific microarray analysis of intestinal gene expression during *X. laevis* metamorphosis identified several candidate stem cell genes. We carried out a detailed analyses of one such gene, amidohydrolase domain-containing 1 (*AMDHD1*) gene, which encodes an enzyme in the histidine catabolic pathway (Reference 4). We showed that *AMDHD1* is exclusively expressed in proliferating adult epithelial stem cells during metamorphosis with little expression in other intestinal tissues. We further provided evidence that TH activates *AMDHD1* gene expression directly at the transcription level through TH-receptor binding to the *AMDHD1* gene in the intestine. In addition, we reported earlier that the histidine ammonia-lyase (*HAL*) gene, another gene in histidine catabolic pathway, is similarly regulated by TH in the intestine. Taken together, the results suggest that histidine catabolism plays a critical role in the formation and/or proliferation of adult intestinal stem cells during metamorphosis.

## Distinct transformations of intestinal epithelial cells during *Xenopus* metamorphosis revealed by molecular and cytological analyses

Earlier studies revealed several cytological and molecular markers for intestinal epithelial cells undergoing different changes during metamorphosis. However, the lack of established double labeling has made it difficult to ascertain the identities of the metamorphosing epithelial cells. We carried out double staining with several different cytological and molecular markers during TH-induced and natural metamorphosis in *X. laevis* (Reference 5). Our studies demonstrated conclusively that the clusters of proliferating cells in the epithelium at the climax of metamorphosis are undifferentiated epithelial cells and that they express the well known adult intestinal stem cell marker gene *Lgr5*. We further showed that, during metamorphosis, adult stem cells and apoptotic larval epithelial cells are distinct epithelial cells. Our findings suggest that, in response to TH during metamorphosis, morphologically identical larval epithelial cells choose two alternative paths: programmed cell death or dedifferentiation to form adult stem cells, with apoptosis occurring prior to the formation of the proliferating adult stem cell clusters (islets).

## Additional Funding

- Japan Society for the Promotion of Science (JSPS) fellowships for Drs. Morihiro Okada and Yuki Shibata

## Publications

1. Wen L, Fu L, Guo X, Chen Y, Shi Y-B. Histone methyltransferase Dot1L plays a role in postembryonic development in *Xenopus tropicalis*. *FASEB J* 2015 29:385-393.
2. Wang F, Shi Z, Cui Y, Guo X, Shi Y-B, Chen Y. Targeted gene disruption in *Xenopus laevis* using CRISPR/Cas9. *Cell Biosci* 2015 5:15.

3. Wen L, Shi Y-B. Unliganded thyroid hormone receptor controls developmental timing in *Xenopus tropicalis*. *Endocrinology* 2015 156:721–734.
4. Okada M, Miller TC, Fu L, Shi Y-B. Direct activation of amidohydrolase domain-containing 1 gene by thyroid hormone implicates a role in the formation of adult intestinal stem cells during *Xenopus* metamorphosis. *Endocrinology* 2015 156:3381–3393.
5. Okada M, Wen L, Miller TC, Su D, Shi Y-B. Molecular and cytological analyses reveal distinct transformations of intestinal epithelial cells during *Xenopus* metamorphosis. *Cell Biosci* 2015 5:74.

## Collaborators

- Yonglong Chen, PhD, *South University of Science and Technology of China, Shenzhen, China*
- Atsuko Ishizuya-Oka, PhD, *Nippon Medical School, Tokyo, Japan*
- Daiwen Pang, PhD, *Wuhan University, Wuhan, China*

## Contact

For more information, email [shi@helix.nih.gov](mailto:shi@helix.nih.gov) or visit <http://smm.nichd.nih.gov>.

## Modeling the Biophysics of the Membrane

Mechanisms of protein function are determined at the molecular level. For example, a G protein-coupled receptor (GPCR) binds to a drug or signaling molecule, and the shape of the protein is modified (a new conformation). The conformation is sensed inside the cell. The molecular movements are on the sub-nanometer scale, 10 billion times smaller than a meter. Such molecular events can then trigger changes in the cell at a scale one hundred thousand times larger. The whole process requires a complex coordination of many such events.

The goal of models and simulation is to be the computational extension of knowledge in the field of molecular biology. The models incorporate not only laboratory observations but also bottom-up molecular physics. The ultimate goal is to make predictions of how external factors (such as disease) affect a biological function and to help develop potential cures that consider, for example, side effects that may be unanticipated by attempting to target a single protein. A more modest goal is to identify missing pieces of a biological puzzle where, for example, our collective knowledge and intuition are inconsistent with observations.

The piece of the puzzle studied in this lab is the role of the lipid membrane of the cell. The membrane deserves independent study because of its essential role in signaling. It is the chemical and informational barrier between the cell and organism, as well as between intracellular compartments. It must be reshaped and transformed during, for example, neurological function, formation of cellular organelles and vesicles, or the viral replication cycle. Along with the cytoskeleton, it is the major structural element that gives a cell its form.

A broad objective is to create a publicly available software package that can be either used as a stand-alone application for analyzing membrane-reshaping processes or as a library for cellular-scale modeling packages where the role of the membrane may be unclear or unanticipated. The model will incorporate the physical mechanisms we are investigating in the narrower objectives of the lab. These include: the influence of lipid curvature stress on the conformation of a protein; whether through-bilayer coupling can amplify a signaling state (for example, of a GPCR); and whether

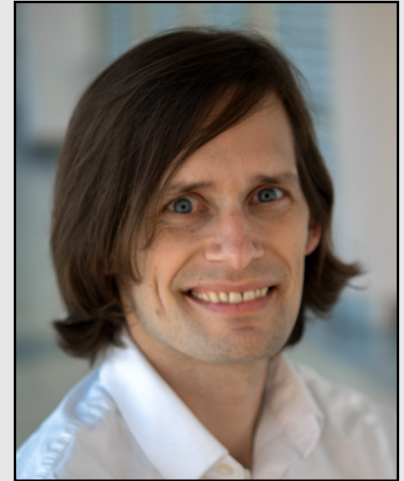

**Alexander J. Sodt, PhD, Head,**  
*Unit on Membrane Chemical  
Physics*

Victor Chernomordik, PhD,  
*Volunteer*

Christina M. Freeman, BS,  
*Postbaccalaureate Fellow*

Julia Rakas, *Summer Student*

Maya Wilson, *Summer Student*

protein motifs (e.g., a thick hydrophobic region of a protein) can enhance the local lipid composition around a protein. These projects will address how the lipid micro-environment is controlled by the cell to change coupling between protein signaling states.

The purpose of the ongoing projects of the Unit is to investigate the physical mechanisms by which the lipid membrane influences the protein function that underlies most biological processes. A typical project in the lab identifies a hypothesis for a particular mechanism in conceptual terms, forms a mathematical or physical model for the process, then tests and refines the model using a molecular simulation. The project is then developed to make predictions that can be tested in the laboratory.

The projects use the NIH Biowulf computing cluster to run the simulations and models. Molecular dynamics software (such as NAMD and CHARMM) are used to conduct molecular simulations. In-house software development for eventual public distribution is a key element of the lab's work.

## Effect of protein palmitoylation on curvature stress

Enveloped viruses bud off the cell, incorporating the plasma membrane into their envelope. Preliminary experiments from the Zimmerberg lab showed that palmitoylation of the HA influenza protein reduces the size of viral-like particles (VLP). A model for this effect is that palmitoylation affects the lateral stress of the budded membrane, stabilizing high curvature. This will be tested in simulation by examining the curvature effect of free palmitic acid (using techniques refined in Dr. Sodt's post-doctoral work) and comparing the effect with palmitoylation of peptide motifs.

## Theory of the Hofmeister effect on membrane material properties

The Hofmeister effect is broadly understood to be a change in the effective surface tension between water and oily substances as a result of charged ions. The lab is generally interested in how the chemistry of the elements of the membrane affect bilayer properties, and a surfactant-laden interface between oil and water is a simple model of the leaflet surface.

First, we are developing a theoretical model for how surface-bound ions affect the material properties of the bilayer, e.g., stiffness. This can be verified by simulations of a bilayer conducted in the presence of a series of, for example, halide anions. It is expected that the larger iodine ion is able to permeate the bilayer more than the smaller halides, which would lead to a change in the chemical interactions at the surface, and thus, its material properties. The model is being used by the Bezrukov lab to interpret the effect of Hofmeister anions on the function of ion channels.

## Development of software and models to characterize lipid-protein interactions

A software package is being developed to compute the effect of membrane deformations between two or more proteins in close proximity. The "continuum" model will be used to help explain cooperative effects between rhodopsin proteins observed in the lab of Klaus Gawrisch. We are validating the model and software in part by conducting molecular simulations of rhodopsin states and comparing the predicted deformations between the molecular and continuum models.

## Publications

1. Sodt A, Venable R, Lyman E, Pastor R. Nonadditive compositional curvature energetics of lipid bilayers. *Phys Rev Lett* 2016 117:138104.

## Collaborators

- Sergey Bezrukov, PhD, *Section on Molecular Transport, NICHD, Bethesda, MD*
- Klaus Gawrisch, PhD, *Laboratory of Membrane Biochemistry and Biophysics, NIAAA, Bethesda, MD*
- Edward Lyman, PhD, *University of Delaware, Newark, DE*
- Joshua Zimmerberg, MD, PhD, *Section on Cellular and Membrane Biophysics, NICHD, Bethesda, MD*

## Contact

For more information, email [alexander.sodt@nih.gov](mailto:alexander.sodt@nih.gov) or visit <http://sodtlab.nichd.nih.gov>.



## Signaling and Secretion in Neuroendocrine Cells

We investigate cellular signaling cascades, gene expression, and hormone secretion in hypothalamic and pituitary cells, with a special emphasis on the interactions between plasma-membrane electrical events and receptor-controlled pathways. Specifically, we are addressing how these neuroendocrine cells use ion channels and G protein-coupled receptors as signaling platforms to efficiently process information. To this end, we characterize both native and recombinant receptors and channels that have been cloned from neuroendocrine cells. In the past, our work has focused on the role of inositol-trisphosphate receptors in the oscillatory calcium release of pituitary cells, the mechanism of periodic activation of these channels, and the complex mode of synchronization of calcium release from intracellular stores with electrical activity of cells. We also characterized voltage-gated channels expressed in neuroendocrine cells, the cell type-specific patterns of electrical activity and channels involved, the physiological relevance of such activity, and the crosstalk between G protein-coupled receptors and ion channels. More recently, we characterized ligand-gated receptor channels expressed in pituitary cells, including the ATP-gated P2X receptor channels. Our current work focuses on age-, sex-, and tissue structure-specific signaling, transcription and secretion in the pituitary gland, the heterogeneity of secretory pituitary cells reflecting their embryonal and postnatal genesis, and cell type-specific exocytic pathways. We are also studying how the structural features of P2X receptors relate to the channels' functions and how plasma membrane receptors and the intracellular signaling milieu affect channel activity.

### Electrophysiological properties, calcium signaling, and gene expression in pituitary corticotrophs

Our recent work with corticotrophs focused on three subjects: (1) the developmental pattern of pro-opiomelanocortin gene (*Pomc*) expression, (2) rapid glucocorticoid effects on corticotrophs function, and (3) electrophysiological characterization of spontaneous and corticotropin-releasing hormone (CRH)-stimulated cells. The qRT-PCR analysis using pre-designed TaqMan Gene Expression Assays, which is a sensitive and reliable method to study gene expression in both male and female pituitaries *in vivo* and *in vitro*, revealed

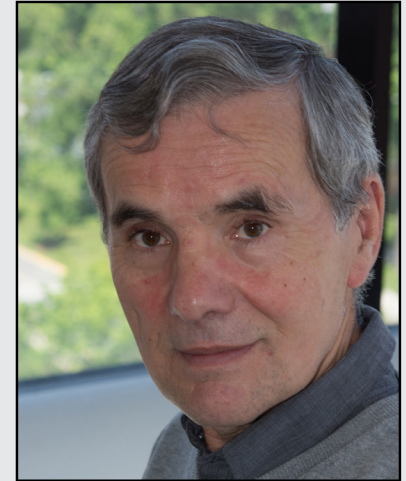

**Stanko S. Stojilkovic, PhD, Head,**  
*Section on Cellular Signaling*  
 Melanija Tomić, PhD, *Staff Scientist*  
 Marija M. Janjic, PhD, *Visiting Fellow*  
 Milos B. Rokic, PhD, *Visiting Fellow*  
 Xinjie Yang, MD, PhD, *Visiting Fellow*  
 Jovana Tavcar, MD, *Special Volunteer*  
 Rafael M. Previde, MD, *Special Volunteer (PhD Student)*

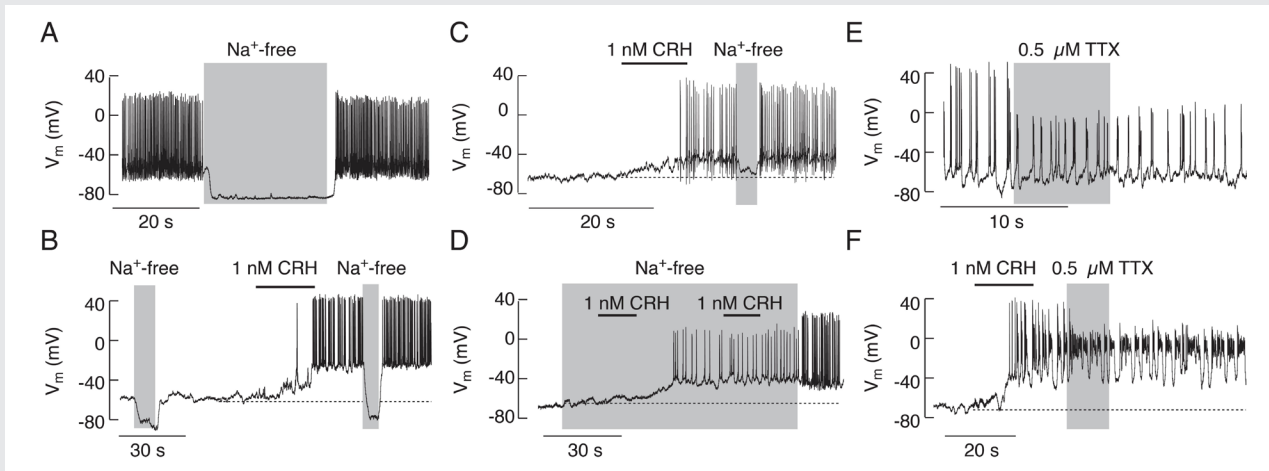
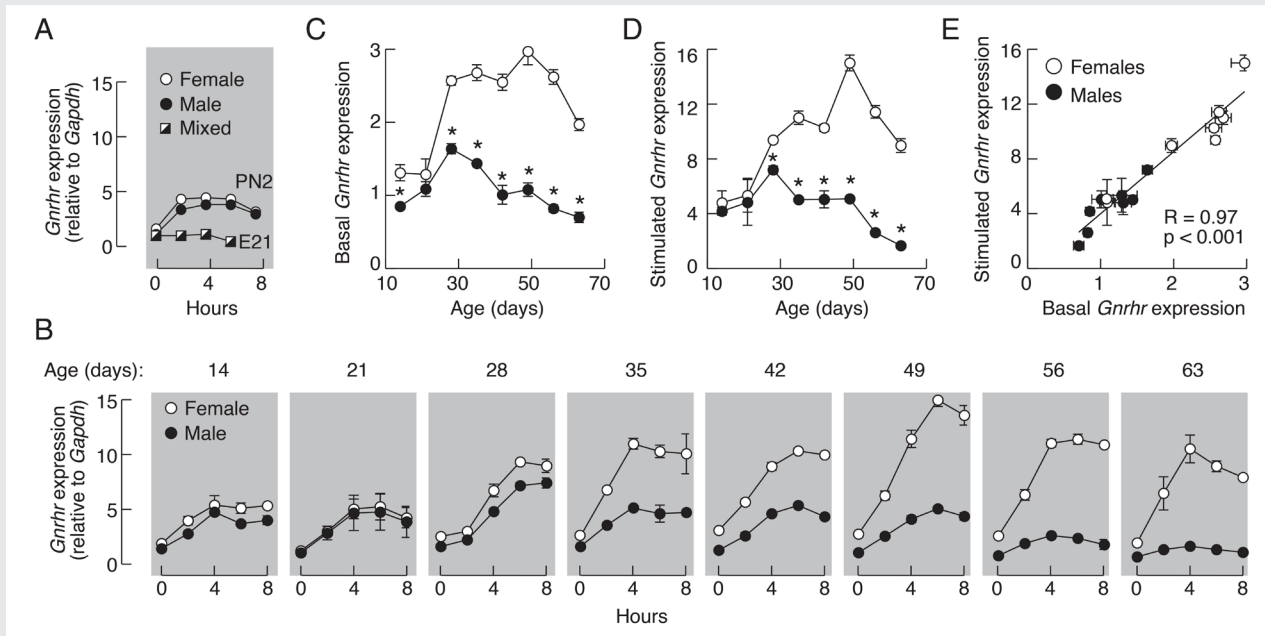

**FIGURE 1. Dependence of spontaneous and CRH-induced firing of action potentials on sodium conductance in pituitary corticotrophs**

A. Substitution of bath  $\text{Na}^+$  with the organic monovalent cation *N*-methyl-D-glucamine (NMDG<sup>+</sup>) caused deep hyperpolarization and abolished spontaneous AP firing. B and C. Removal of bath  $\text{Na}^+$  also abolished CRH-induced electrical activity. D. In cells bathed in  $\text{Na}^+$ -free media, CRH was able to depolarize the plasma membrane and initiate the firing of low-amplitude APs; the amplitude and frequency of spiking increased after the return of bath  $\text{Na}^+$ . E. Application of tetrodotoxin (TTX), a specific blocker of voltage-gated  $\text{Na}^+$  ( $\text{Na}_v$ ) channels, did not abolish spontaneous or (F) CRH-induced firing of APs, but reduced the amplitude of spiking.

that corticotrophs show comparable expression profiles of *Pomc* in both sexes, with the highest expression occurring during the infantile period. Collaborative experiments with Greti Aguilera, using cultured pituitary cells, hypothalamic-derived 4B cells, and AtT-20 cells, revealed that the nongenomic/membrane effects of the classical glucocorticoid receptor mediate rapid and reversible glucocorticoid feedback inhibition at the pituitary corticotrophs downstream of calcium influx. The sensitivity and kinetics of these effects is consistent with the hypothesis that pituitary glucocorticoid feedback is part of the mechanism for adrenocortical ultradian pulse generation.

In contrast to gonadotrophs, lactotrophs, and somatotrophs, the ion channels and mechanisms controlling corticotroph excitability are still not well understood. Development of transgenic mice expressing the tdimer2(12) form of *Discosoma* red fluorescent protein under control of the *POMC* gene's regulatory elements are a useful model for studying excitability of corticotrophs and melanotrophs. During the initial stage of investigation, done in collaboration with Greti Aguilera, we established a protocol to distinguish between these two cell types. Next, we characterized the resting membrane potential, spontaneous electrical activity, and calcium signaling in corticotrophs. The cells were either quiescent or electrically active, with a 22-mV difference. In quiescent cells, CRH depolarized the membrane, leading to initial single spiking and sustained bursting; in spontaneously firing cells, CRH further facilitated or inhibited electrical activity and calcium spiking, depending on the initial activity pattern and CRH concentration. The stimulatory action of CRH was mimicked by the cAMP activator forskolin and a cell-permeable cAMP analog. Removal of bath sodium silenced spiking and hyperpolarized the majority of cells (Figure 1); in contrast, the removal of bath calcium did not affect resting membrane potential (RMP) but reduced CRH-induced depolarization, which abolished bursting



**FIGURE 2.** Basal and GnRH-regulated rat pituitary *Gnrhr* transcriptions are age and sex dependent.

A and B. Time-course studies of 10 nM GnRH-induced *Gnrhr* expression in embryonal pituitaries (E21), neonatal (PN2), and infant to adult pituitary cells derived from 7 to 20 animals per age group were conducted 48 h after dispersion. The age of animals in panel B is indicated on the top of gray panels. Adult female groups were composed of animals in different stages of estrous cycle.

C–E. The relationship between basal and regulated *Gnrhr* expression in males (closed circles), females (open circles). Data are derived from panel B; the 0 time points were used for basal (C) and the peak responses were used as values for GnRH-stimulated gene expression (D). Asterisks indicate significant differences between pairs, determined by ANOVA.

E. Correlation of basal and regulated rat pituitary *Gnrhr* expression. R, coefficient of correlation.

electrical activity and reduced the spiking frequency but not the amplitude of single spikes. Corticotrophs with inhibited voltage-gated sodium channels fired calcium-dependent action potentials, whereas cells with inhibited L-type calcium channels fired sodium-dependent spikes; blockade of both channels abolished spiking without affecting the RMP. These results indicate that the background voltage-insensitive sodium conductance influences resting membrane potential, the CRH-depolarization current is driven by a cationic conductance, and the interplay between voltage-gated sodium and calcium channels plays a critical role in determining the status and pattern of electrical activity and calcium signaling (Reference 1).

## Signature gene expression in pituitary gonadotrophs

The most obvious functional differences between mammalian males and females are related to the control of reproductive physiology and include patterns of gonadotropin-releasing hormone (GnRH) and gonadotropin release, the timing of puberty, sexual and social behavior, and the regulation of food intake and body weight. Using the rat as the best studied mammalian model for maturation, we recently examined the expression of the gonadotroph signature genes GnRH receptor gene (*Gnrhr*), follicle-stimulating hormone beta subunit gene (*Fshb*), luteinizing hormone beta subunit gene (*Lhb*), and alpha subunit gene

(*Cga*) in developing males and females, using qRT-PCR and predesigned Taq-Man Gene Expression assays. Gonadotrophs exhibit highly synchronized *Lhb*, *Fshb*, *Cga*, and *Gnrhr* gene expression in both sexes, but the peak of expression occurs during the infantile period in females and at the end of the juvenile period in males. The results indicate a time shift in the peak expression during postnatal development, most likely reflecting the perinatal sex-specific brain differentiation.

In further work on this topic, we focused on basal and regulated expression of *Gnrhr* transcription. It is well established that hypothalamic GnRH, together with gonadal steroids and activins/inhibin, regulate the receptor's gene expression *in vivo*, which leads to crucial changes in GnRHR numbers on the plasma membrane. This is accompanied by alterations in gonadotroph sensitivity and responsiveness during physiologically relevant situations. However, the signaling pathways accounting for basal and regulated *Gnrhr* expression have not been systematically investigated. Our *in vitro* investigations revealed that *Gnrhr* expression was progressively reduced but not completely abolished in pituitary cells from adult animals cultured in the absence of GnRH and steroid hormones. The basal *Gnrhr* expression was also operative in LbetaT2 immortalized gonadotrophs never exposed to GnRH. In both cell types, basal transcription was sufficient for the expression of functional GnRHRs. Continuous application of GnRH transiently elevated *Gnrhr* expression in cultured pituitary cells followed by a sustained fall without affecting basal transcription. Both basal and regulated *Gnrhr* transcription was dependent on the protein kinase C signaling pathway. The GnRH-regulated *Gnrhr* expression was not operative in embryonal pituitary and LbetaT2 cells but was established neonatally, the sex-specific response patterns were formed at the juvenile-peripubertal stage, and there was a strong correlation between basal and regulated gene expression during development (Figure 2). Thus, age-dependent basal and regulated *Gnrhr* transcription could account for initial blockade and subsequent activation of the reproductive system during development (Reference 2).

## Dependence of P2X2R functions on its phosphorylation status and expression pattern

The purinergic P2X2 receptor (P2X2R) is an ATP-gated ion channel widely expressed in the nervous and neuroendocrine systems. Recently, we identified a putative Cdk5 (cyclin-dependent-like kinase 5, a crucial regulator of neuronal migration in the developing central nervous system) phosphorylation site in the full-size variant P2X2aR (372TPKH375), which is absent from the splice variant P2X2bR. We therefore investigated the effects of Cdk5 and its neuronal activator, p35, on P2X2aR functions. Using co-immunofluorescence and co-immunoprecipitation in HEK293 cells expressing those constructs, we found an interaction between P2X2aR and Cdk5/p35. We also found that threonine phosphorylation was significantly increased in P2X2aR. Moreover, P2X2aR-derived peptides, including the Cdk5 consensus motif, were phosphorylated *in vitro* by Cdk5/p35. Whole-cell patch-clamp current recordings indicated a delay in the development of use-dependent desensitization of P2X2aR but not of P2X2bR in HEK293 cells co-expressing those receptors with p35. In addition, P2X2aRs expressed in *Xenopus* oocytes desensitized more slowly than in HEK293 cells, and Cdk5 activation prevented this effect. The P2X2aR-T372A mutant was also resistant to use-dependent desensitization. In endogenous systems, we observed an interaction culture of nociceptive neurons. Moreover, using co-immunoprecipitation we observed interaction between Cdk5 and P2X2R in mouse trigeminal ganglia. Also, given that inhibition with roscovitine accelerated the desensitization kinetics of the currents, endogenous P2X2aR-mediated currents in PC12 cells were dependent on Cdk5 activity. The results suggest that the P2X2aR is a novel target for Cdk5-mediated phosphorylation, which might play an important role in relevant physiological processes, including pain signaling (manuscript submitted for publication).

Synaptic refinement and strengthening are activity-dependent processes, which establish orderly arranged cochleotopic maps throughout the central auditory system. The maturation of auditory brainstem circuits is guided by action potentials (APs) arising from the inner hair cells in the developing cochlea. The goal of our collaborative study with Ivan Milenkovic was to describe the tonotopic pattern of purinergic modulation during early postnatal development of the cochlear nucleus. In addition, the temporal properties of APs in neurons affected by ATP were investigated in detail using *in vivo* juxtacellular recordings and whole-cell recordings in acute slices. Also, we used pharmacological and molecular biological approaches to identify the P2XR subtypes accounting for effects. Using slice recordings before hearing onset and *in vivo* recordings with iontophoretic drug applications after hearing onset, we showed that cell-specific purinergic modulation follows a precise tonotopic pattern in the ventral cochlear nucleus of developing gerbils. In high-frequency regions, ATP responsiveness diminished before hearing onset. In low-to-mid frequency regions, ATP modulation persisted after hearing onset in a subset of low-frequency bushy cells [characteristic frequency (CF) less than 10 kHz]. Down-regulation of P2X2/3R currents along the tonotopic axis occurs simultaneously with an increase in AMPAR (glutamate receptor) currents, thus suggesting a high-to-low frequency maturation pattern. Facilitated AP generation, measured as higher firing frequency, shorter EPSP-AP (excitatory postsynaptic potential/action potential) delay *in vivo*, and shorter AP latency in slice experiments, is consistent with increased synaptic efficacy caused by ATP. Also, by combining electrophysiological recordings and pharmacology *in vivo*, in slices, and in HEK cells, we showed that the long-lasting change in intrinsic neuronal excitability is mediated by the P2X2/3R (Reference 3).

## Publications

1. Zemkova H, Tomić M, Kucka M, Aguilera G, Stojilkovic SS. Spontaneous and CRH-induced excitability and calcium signaling in mice corticotrophs involves sodium, calcium, and cation-conducting channels. *Endocrinology* 2016 157:1576-1580.
2. Bjelobaba I, Janjic MM, Tavcar JS, Kucka M, Tomić M, Stojilkovic SS. The relationship between basal and regulated Gnrhr expression in rodent pituitary gonadotrophs. *Mol Cell Endocrinol* 2016 437:302-311.
3. Jovanovic S, Radulovic T, Coddou C, Dietz B, Nerlich J, Stojilkovic SS, Rubsamen R, Milenkovic I. Tonotopic action potential tuning of maturing auditory neurons through endogenous ATP. *J Physiol* 2016; in press.
4. Trivellin G, Bjelobaba I, Daly AF, Larco DO, Palmeira L, Faucez FR, Thiry A, Leal LF, Rostomyan L, Quezado M, Scherthaner-Reiter MH, Janjic MM, Villa C, Wu TJ, Stojilkovic SS, Beckers A, Feldman B, Stratakis CA. Characterization of GRP101 transcript structure and expression patterns. *J Mol Endocrinol* 2016 57:97-111.
5. Bertram R, Tabak J, Stojilkovic SS. Ion channels and electrical activity in pituitary cells: a modeling perspective. In: MacGregor DJ, Leng G, eds. *Computational Neuroendocrinology, First Edition*. John Wiley & Sons. 2016 80-110.

## Collaborators

- Claudio Coddou, PhD, *Faculty of Medicine, Universidad Católica del Norte, Coquimbo, Chile*
- Ivan Milenkovic, PhD, *Universität Leipzig, Leipzig, Germany*
- Hana Zemková, PhD, *Institute of Physiology, Czech Academy of Sciences, Prague, Czech Republic*

## Contact

For more information, email [stankos@helix.nih.gov](mailto:stankos@helix.nih.gov) or visit <https://irp.nih.gov/pi/stanko-stojilkovic> or <https://neuroscience.nih.gov/Faculty/Profile/stanko-stojilkovic.aspx>.

## Olfactory Coding and Decoding by Ensembles of Neurons

All animals need to know what is going on in the world around them. Brain mechanisms have thus evolved to gather and organize sensory information in order to build transient and sometimes enduring internal representations of the environment. Using relatively simple animals and focusing primarily on olfaction and gustation, we combine electrophysiological, anatomical, behavioral, computational, genetic, and other techniques to examine the ways in which intact neural circuits, driven by sensory stimuli, process information. Our work reveals basic mechanisms by which sensory information is transformed, stabilized, and compared, as it makes its way through the nervous system.

### Neural encoding of odors during active sampling and in turbulent plumes

An important feature of sensory modalities is that natural sensory stimuli can be distorted by environmental or active events leading, for example, to stimulus intermittency. Passive causes of olfactory intermittency include air or water turbulence, breaking up, for example, an odor plume into concentrated packets, or filaments of odor separated by pockets of very low odor concentration. The second cause is self-generated or active and results from the animal's own sampling behaviors, including sniffing in mammals and olfactory appendage flicking in crustaceans and insects. Little is known about how neural circuits encode the resulting stimuli or about the behaviors animals use to interact with them.

To evaluate the effects of stimulus variability caused by odor plume turbulence and active sampling, we developed two novel experimental paradigms with locusts to isolate and characterize the two causes of intermittency. With a fixed-antenna wind-tunnel preparation, we could investigate neural coding features elicited by chaotic, natural odor plumes. Despite their irregularity, chaotic odor plumes still drove dynamic neural response features including the synchronization, temporal patterning, and short-term plasticity of spiking in projection neurons, enabling classifier-based stimulus identification and activating downstream decoders (Kenyon cells). With an active-sampling preparation, in which locusts were free to flick their antenna through a linear odor filament and walk freely



**Mark Stopfer, PhD**, *Head, Section on Sensory Coding and Neural Ensembles*

Zane Aldworth, PhD, *Staff Scientist*

Yu-Shan Hung, PhD, *Postdoctoral Fellow*

Subhasis Ray, PhD, *Postdoctoral Fellow*

Kazumichi Shimizu, PhD, *Postdoctoral Fellow*

Kui Sun, MD, *Technician*

on a substrate, we could combine behavioral analyses with electrophysiology to address the functional significance of self-induced stimulus intermittency for olfactory coding. Odors triggered immediate, spatially targeted antennal scanning that, paradoxically, weakened individual neural responses. However, these frequent but weaker responses were highly informative about stimulus location.

Our results show that spatio-temporally structured neural responses efficiently encode naturally chaotic and intermittent olfactory stimuli and that active sampling behaviors take advantage of this ability by increasing intermittency to gain more information about an odor's location.

## Identified gustatory second-order neuron in the *Drosophila* brain

Little is known, in any species, about neural circuitry immediately following gustatory sensory neurons, which makes it difficult to know how gustatory information is processed by the brain. By genetically labeling and manipulating specific parts of the nervous system, we identified and characterized a bilateral pair of gustatory second-order neurons in *Drosophila*. Previous studies had already identified gustatory sensory neurons that relay information to distinct parts of the gnathal (sub-esophageal) ganglia. To identify candidate gustatory second-order neurons, we took an anatomical approach. We screened about 5,000 GAL4 driver strains for lines that label neural fibers innervating the gnathal ganglia. We then combined GRASP (GFP reconstitution across synaptic partners) with presynaptic labeling to visualize potential synaptic contacts between the dendrites of the candidate gustatory second-order neurons and the axonal terminals of Gr5a-expressing sensory neurons, which have been shown to respond to sucrose. Results of the GRASP analysis, followed by a single-cell analysis by FLP-out recombination, identified a specific pair of neurons that contact Gr5a axon terminals in both brain hemispheres and send axonal arborizations to a distinct region within the gnathal ganglia. To characterize the input and output branches, respectively, we expressed the fluorescence-tagged acetylcholine receptor subunit (Da7) and active-zone marker (Brp) in the gustatory second-order neurons.

We found that input sites of the gustatory second-order neurons overlaid GRASP-labeled synaptic contacts to Gr5a neurons, while presynaptic sites were broadly distributed throughout the neurons' arborizations. GRASP analysis and further tests with a new version of GRASP that labels active synapses suggested that the identified second-order neurons receive synaptic inputs from Gr5a-expressing sensory neurons, but not from Gr66a-expressing sensory neurons, which respond to caffeine. The identified second-order neurons relay information from Gr5a-expressing sensory neurons to stereotypical regions in the gnathal ganglia. Our findings suggest an unexpected complexity for taste-information processing in the first relay of the gustatory system. We are presently following up on this work to identify additional second-order neurons and, with optical imaging and intracellular electrophysiology experiments, to characterize their functions and information-coding strategies.

## Spatiotemporal coding of individual chemicals by the gustatory system

Four of the five major sensory systems (vision, olfaction, somatosensation, and audition) are thought to be encoded by spatio-temporal patterns of neural activity. The only exception is gustation. Gustatory coding by the nervous system is thought to be relatively simple: every chemical ('tastant') is associated with one of a small number of basic tastes, and the presence of a basic taste, rather than the specific tastant, is represented by the brain. In mammals as well as insects, five basic tastes are usually recognized: sweet, salty, sour, bitter, and umami. The neural mechanism for representing basic tastes is unclear. The most

widely accepted proposal is that, in both mammals and insects, gustatory information is carried through labelled lines: separate channels, from the periphery to sites deep in the brain, of cells sensitive to a single basic taste. An alternate proposal is that the basic tastes are represented by populations of cells, with each cell sensitive to multiple basic tastes.

Testing these ideas requires determining, point-to-point, how tastes are initially represented within the population of receptor cells and how this representation is transformed as it moves to higher-order neurons. However, it has been highly challenging to deliver precisely timed tastants while recording cellular activity from directly connected cells at successive layers of the gustatory system. Using a new moth preparation, we designed a stimulus and recording system that allowed us to fully characterize the timing of tastant delivery and the dynamics of the tastant-elicited responses of gustatory receptor neurons and their mono-synaptically connected second-order gustatory neurons, before, during, and after tastant delivery.

Surprisingly, we found no evidence consistent with a basic taste model of gustation. Instead, we found that the moth's gustatory system represents individual tastant chemicals as spatio-temporal patterns of activity distributed across the population of gustatory receptor neurons. Further, we found that the representations are transformed substantially as many types of gustatory receptor neurons converge broadly upon follower neurons. The results of our physiological and behavioral experiments suggest that the gustatory system encodes information not about basic taste categories but rather about the identities of individual tastants. Further, the information is carried not by labelled lines but rather by distributed, spatio-temporal activity, which is a fast and accurate code. The results provide a dramatically new view of taste processing.

## Tradeoff between information format and capacity in the olfactory system

How does the nervous system 'decide' what format to use to encode information? The brain's internal representation of the environment is built from patterns of neural activity bearing information about sensory stimuli. As this activity travels through the brain, a succession of neural circuits manipulates it into a series of coding formats, each thought to provide specific advantages for processing information. Each coding format has, however, advantages and disadvantages. How the benefits of a given format are balanced against its costs is largely unknown.

One common coding format uses periodic inhibition to coordinate neural spiking into synchronous oscillations. It has been proposed that oscillatory synchrony offers several benefits, including enhancing the discriminability of sensory representations and 'binding' diverse stimulus features into coherent percepts. We examined how neural oscillatory synchronization affects another measure of coding quality: the rate at which information is transmitted. We evaluated this potential tradeoff between coding format and information rate in the olfactory system of the locust. To test the possible tradeoffs imposed by synchrony, we needed a richly structured olfactory stimulus appropriate for the measurement of information properties. We decided to focus on stimulus timing because we could provide, with a synthetic odor plume, a broad sample of an environmentally meaningful stimulus space. Using artificial plumes based on the statistical structures of temporal variability measured outdoors in real odor plumes allowed us to calculate lower bound estimates of information in the temporal structure of an ethologically relevant stimulus. Thus, we delivered odorants as controlled, repeatable plumes while recording responses from populations of projection neurons as they transmitted information about the plume's temporal structure. We evaluated the



information content of neurons in terms of the mutual information rate between the temporal dynamics of the odorant stimulus and the neuronal response by finding the difference between the unconditional and stimulus-conditioned response entropies.

Surprisingly, our results showed that pharmacologically blocking synchronization by locally injecting picrotoxin led to a significant increase in information rate. Thus, the use of a synchronous coding scheme introduces a tradeoff: synchrony allows correlation coding and fine olfactory discrimination; however, by reducing the number of spikes and spike positions available for encoding information, synchrony also reduces the ability of the system to rapidly transmit information about the stimulus. The inhibition-induced reduction in transmission capacity that we observed in the olfactory system likely occurs in any neural circuit using periodic inhibition. Our results suggest that reformatting to an oscillatory structure comes at a cost and thus represents a fundamental tradeoff between coding capacity and other aspects of format utility.

## Additional Funding

- NICHD Director's Award for a collaborative grant written by Mark Stopfer and Chi-Hon Lee.

## Publications

1. Reiter S, Campillo Rodriguez C, Sun K, Stopfer M. Spatiotemporal coding of individual chemicals by the gustatory system. *J Neurosci* 2015 35:12309-12321.
2. Huston SJ, Stopfer M, Cassenaer S, Aldworth ZN, Laurent G. Neural encoding of odors during active sampling and in turbulent plumes. *Neuron* 2015 88:1-16.
3. Aldworth Z, Stopfer M. Tradeoff between information format and capacity in the olfactory system. *J Neurosci* 2015 35:1521-1529.
4. Miyazaki T, Lin TY, Ito K, Lee CH, Stopfer M. A gustatory second-order neuron that connects sucrose-sensitive primary neurons and a distinct region of the gnathal ganglion in the *Drosophila* brain. *J Neurogenet* 2015 29(2-3):144-155.
5. Kee T, Sanda P, Gupta N, Stopfer M, Bazhenov M. Feed-forward versus feedback inhibition in a basic olfactory circuit. *PLoS Comput Biol* 2015 11:e1004531.

## Collaborators

- Maxim Bazhenov, PhD, *Howard Hughes Medical Institute, The Salk Institute for Biological Studies, La Jolla, CA*
- Kei Ito, PhD, *University of Tokyo, Tokyo, Japan*
- Gilles Laurent, DVM, PhD, *Director, Max Planck Institute for Brain Research, Frankfurt/Main Germany*
- Chi-Hon Lee, MD PhD, *Section on Neuronal Connectivity, NICHD, Bethesda, MD*

## Contact

For more information, email [stopferm@mail.nih.gov](mailto:stopferm@mail.nih.gov) or visit <https://neuroscience.nih.gov/Faculty/Profile/mark-stopfer.aspx> or <https://irp.nih.gov/pi/mark-stopfer>.

## Regulatory Small RNAs and Small Proteins

Currently, we have two main interests: identification and characterization of small noncoding RNAs and identification and characterization of small proteins of less than 50 amino acids. Both small RNAs and small proteins have been overlooked because they are not detected in biochemical assays and the corresponding genes are poorly annotated and missed in genetic screens. However, mounting evidence suggests that both classes of small molecules play important regulatory roles.

### Identification and characterization of small regulatory RNAs

During the past 15 years, we have carried out several different systematic screens for small regulatory RNA (sRNA) genes in *Escherichia coli*. The screens included computational searches for conservation of intergenic regions and direct detection after size selection or co-immunoprecipitation with the RNA-binding protein Hfq. We recently examined sRNA expression using deep sequencing to extend our identification of sRNAs, particularly antisense RNAs (Thomason MK *et al.* *J Bacteriol* 2015;197:18).

A major focus for the group has been to elucidate the functions of the sRNAs we and others identified. Early on, we showed that the OxyS RNA, whose expression is induced in response to oxidative stress, acts to repress translation through limited base pairing with target mRNAs. We discovered that OxyS action is dependent on the Sm-like Hfq protein, which acts as a chaperone to facilitate OxyS RNA base pairing with its target mRNAs (Gottesman S, Storz G. *RNA* 2015;21;511). Recently, we carried out extensive mutational studies of Hfq (Shu DJ *et al.* *EMBO J* 2015;34:2557). The analysis revealed that amino acids on three different RNA-interaction surfaces—the proximal face, the distal face, and the rim of the doughnut-shaped protein—differentially impact Hfq association with sRNAs and their mRNA targets (Reference 1) (Figure 1).

It is now clear that Hfq-binding sRNAs, which act through limited base pairing, are integral to many different stress responses in *E. coli* and other bacteria (Reference 2). For example, we showed that the Spot 42 RNA, whose levels are highest when glucose is



**Gisela Storz, PhD, Head, Section on Environmental Gene Regulation**

Aixia Zhang, PhD, Staff Scientist

Tamira K. Butler-Lively, PhD, Postdoctoral Fellow

Michael D. Dambach, PhD, Postdoctoral Fellow

Andrew B. Kouse, PhD, Postdoctoral Fellow

Sahar S. Melamed, PhD, Postdoctoral Fellow

Mona Wu Orr, PhD, Postdoctoral Fellow

Medha V. Raina, PhD, Postdoctoral Fellow

Taylor B. Updegrove, PhD, Postdoctoral Fellow

Jeremy S. Weaver, PhD, Postdoctoral Fellow

Joshua M. Mills, BS, Postbaccalaureate Fellow

Aracely A. Romero, BS, Postbaccalaureate Fellow

Hira Shabbir, BS, Postbaccalaureate Fellow

Hanbo Wang, BS, Graduate Student

**FIGURE 1. Model of Hfq-facilitated base pairing between sRNAs and mRNAs**

*E. coli* Hfq (teal for the proximal face and rim views and green for the distal face view) employs four solvent-exposed surfaces to interact with RNA; sRNAs (red) have been found to contact the proximal and distal faces, rim, and C-terminus, and mRNAs (blue) have been shown to contact the distal face, rim, and C-terminus. Red and blue arrows denote sRNA and mRNA binding to Hfq, respectively. Hfq binding to mRNAs and sRNAs is thought to occur in random order. Initial binding is likely to involve only a subset of subunits, allowing for rapid displacement by other RNAs. Many RNAs bind to multiple surfaces, resulting in changes in RNA secondary structure and protection against RNase degradation, particularly for sRNAs. The free surface(s) of Hfq not already bound to RNA interacts with the cognate RNA partner, positioning the unbound seed region of the sRNA in close proximity to the unbound complementary region of the mRNA, facilitating base pairing. The lower affinity of duplex RNA for Hfq causes free RNAs to compete off sRNA–mRNA pairs, allowing Hfq to serve as a matchmaker for another pair of RNAs.

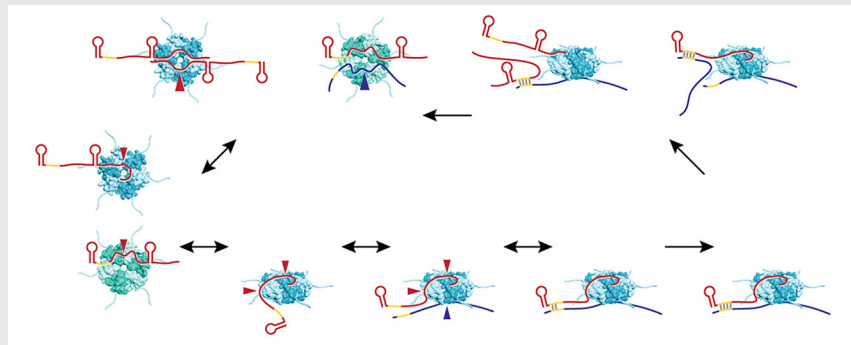

present, plays a broad role in catabolite repression by directly repressing genes involved in central and secondary metabolism, redox balancing, and the consumption of diverse nonpreferred carbon sources. Similarly, we discovered that a Sigma(E)-dependent sRNA, MicL, transcribed from a promoter located within the coding sequence of the *cutC* gene, represses synthesis of the lipoprotein Lpp, the most abundant protein in the cell, to oppose membrane stress. We found that the copper-sensitivity phenotype previously ascribed to inactivation of the *cutC* gene is actually derived from the loss of MicL and elevated Lpp levels. The observation raises the possibility that other phenotypes currently attributed to protein defects are attributable to deficiencies in unappreciated regulatory RNAs (Reference 3). Most recently, we characterized a set of sRNAs expressed from a locus we denoted *sdsN* (Reference 4). Two longer sRNAs, SdsN137 and SdsN178, are transcribed from two Sigma(S)-dependent promoters but share the same terminator. Whole-genome expression analysis after pulse overexpression of SdsN137 and assays of lacZ fusions revealed that the SdsN137 directly represses the synthesis of the nitroreductase NfsA, which catalyzes the reduction of the nitrogroup (NO<sub>2</sub>) in nitroaromatic compounds and the flavohemoglobin HmpA, which has aerobic nitric oxide (NO) dioxygenase activity. Consistent with this regulation, SdsN137 confers resistance to nitrofurans. Interestingly, SdsN178 is defective in regulating the above targets owing to unusual binding to the Hfq protein, but cleavage leads to a shorter form, SdsN124, which is able to repress *nfsA* and *hmpA*.

In addition to sRNAs that act via limited base pairing, we have been interested regulatory RNAs that act by other mechanisms. For example, early work showed that the 6S RNA binds to and modulates RNA polymerase by mimicking the structure of an open promoter. In a more recent study, we discovered that a broadly conserved RNA structure motif, the *yybP-ykoY* motif, found in the 5'-UTR of the *mntP* gene encoding a manganese exporter, directly binds to manganese, resulting in a conformation that liberates the ribosome-binding site (Reference 5). Remarkably, we were able to recapitulate the effect of manganese-dependent activation of translation *in vitro*. We also found that the *yybP-ykoY* motif responds directly to manganese ions

in *Bacillus subtilis*. The identification of the *yybP-ykoY* motif as a manganese ion sensor points to the genes that are preceded by this motif, encode a diverse set of poorly characterized membrane proteins, and play roles in metal homeostasis.

Studies are ongoing to further characterize other Hfq-binding RNAs and their evolution as well as antisense RNAs and sRNAs that act in ways other than base pairing.

## Identification and characterization of small proteins

In our genome-wide screens for sRNAs, we found that several short RNAs do encode small proteins. The correct annotation of the smallest proteins is one of the biggest challenges of genome annotation, and perhaps more importantly, few annotated short open reading frames (ORFs) have been documented to correspond to synthesized proteins. Although these proteins have largely been missed, the few small proteins that have been studied in detail in bacterial and mammalian cells were shown to have important functions in signaling and in cellular defenses (Reference 6). We thus established a project to identify and characterize proteins of less than 50 amino acids.

We used sequence conservation and ribosome binding-site models to predict genes encoding small proteins, defined as having 16–50 amino acids, in the intergenic regions of the model *E. coli* genome. We tested expression of the predicted as well as previously annotated small proteins by integrating the sequential peptide affinity tag directly upstream of the stop codon on the chromosome and assaying for synthesis using immunoblot assays. The approach confirmed that 20 previously annotated and 18 newly discovered proteins of 16–50 amino acids are synthesized. We are now establishing complementary biochemical approaches to identify additional small proteins.

Remarkably more than half the newly discovered proteins are predicted to be single transmembrane proteins, an observation that prompted us to examine the localization, topology, and membrane insertion of the small proteins. Biochemical fractionation showed that, consistent with the predicted transmembrane helix, the small proteins are generally most abundant in the inner membrane fraction. Examples of both  $N_{in}$ - $C_{out}$  and  $N_{out}$ - $C_{in}$  orientations as well as dual topology were found in assays of topology-reporter fusions to representative small transmembrane proteins. In addition, fractionation analysis of small-protein localization in mutant strains uncovered differential requirements for these membrane-insertion pathways. Thus, despite their diminutive size, small proteins display considerable diversity in topology, biochemical features, and insertion pathways.

We now are employing many of the approaches the group has used to characterize the functions of sRNAs to elucidate the functions of the small proteins. Systematic assays for the accumulation of tagged versions of the proteins showed that many small proteins accumulate under specific growth conditions or after exposure to stress. We also generated and screened bar-coded null mutants and identified small proteins required for resistance to cell envelope stress and acid shock. In addition, various tagged derivatives are being exploited to identify co-purifying complexes. The combination of these approaches is giving insights into when, where, and how the small proteins are acting.

For example, we found that synthesis of the 42-amino acid protein MntS is repressed by high levels of manganese through the manganese transporter regulator MntR. We showed that MntS helps manganese

activate a variety of enzymes under manganese-poor conditions, while overproduction of MntS leads to very high intracellular manganese and bacteriostasis under manganese-rich conditions (Reference 7). These and other phenotypes led us to propose that MntS modulates intracellular manganese levels, possibly by inhibiting the manganese exporter MntP.

We also discovered that the 49-amino acid protein AcrZ associates with the AcrAB-TolC multidrug efflux pump, which confers resistance to a wide variety of antibiotics and other compounds. Co-purification of AcrZ with AcrB, in the absence of both AcrA and TolC, two-hybrid assays, and suppressor mutations indicate that this interaction occurs through the inner membrane protein AcrB. Mutants lacking AcrZ are sensitive to many, but not all, antibiotics transported by AcrAB-TolC. The differential antibiotic sensitivity suggests that AcrZ may enhance the ability of the AcrAB-TolC pump to export certain classes of substrate. This work, together with our ongoing studies on other small proteins, suggests that many are acting as regulators of larger membrane proteins.

## Publications

1. Updegrave TB, Zhang A, Storz G. Hfq: the flexible RNA matchmaker. *Curr Opin Microbiol* 2016 30:133-138.
2. Machner MP, Storz G. Infection biology: small RNA with a large impact. *Nature* 2016 529:472-473.
3. Updegrave TB, Shabalina SA, Storz G. How do base-pairing small RNAs evolve?. *FEMS Microbiol Rev* 2015 39:379-391.
4. Hao Y, Updegrave TB, Livingston NN, Storz G. Protection against deleterious nitrogen compounds: role of sigmaS-dependent small RNAs encoded adjacent to sdiA. *Nucleic Acids Res* 2016 44:6935-6948.
5. Dambach M, Sandoval M, Updegrave TB, Anantharaman V, Aravind L, Waters LS, Storz G. The ubiquitous yybP-ykoY riboswitch is a manganese-responsive regulatory element. *Mol Cell* 2015 57:1099-1109.
6. Storz G. New perspectives: insights into oxidative stress from bacterial studies. *Arch Biochem Biophys* 2016 595:25-27.
7. Martin JE, Waters LS, Storz G, Imlay JA. The Escherichia coli small protein MntS and exporter MntP optimize the intracellular concentration of manganese. *PLoS Genet* 2015 11:e1004977.

## Collaborators

- Susan Gottesman, PhD, *Laboratory of Molecular Biology, NCI, Bethesda, MD*
- James A. Imlay, PhD, *University of Illinois, Urbana, IL*
- Aravind L. Iyer, PhD, *National Center for Biotechnology Information, NIH, Bethesda, MD*
- Kay Nieselt, PhD, *Universität Tübingen, Tübingen, Germany*
- Svetlana A. Shabalina, PhD, *National Center for Biotechnology Information, NIH, Bethesda, MD*
- Cynthia M. Sharma, PhD, *Research Centre for Infectious Diseases, Universität Würzburg, Germany*
- Lauren S. Waters, PhD, *University of Wisconsin, Oshkosh, WI*

## Contact

For more information, email [storz@helix.nih.gov](mailto:storz@helix.nih.gov) or visit <http://storz.nichd.nih.gov>.

## Molecular Genetics of Endocrine Tumors and Related Disorders

The project “Molecular Genetics of Endocrine Tumors and Related Disorders” was started in the late 1990s. The goal has always been to identify molecular pathways involved in the first steps of tumor formation. Our approach was to study patients with rare endocrine conditions, mostly inherited, identify the causative genes, and then study the involved signaling pathways in the hope of translating the derived knowledge into new therapies for such patients. The derived knowledge could also be generalized to conditions that are not necessarily inherited, e.g., to more common tumors and diseases caused by defects in the same molecular pathways. The approach has indeed led to fruitful research over the last two decades.

Our first studies led to the identification of the main regulator of the cAMP signaling pathway, the regulatory subunit-type 1A (R1a) of protein kinase A (PKA, encoded by the *PRKAR1A* gene on chromosome 17q22-24), as responsible for primary pigmented nodular adrenocortical disease (PPNAD) and the Carney complex, a multiple endocrine neoplasia (MEN), whose main endocrine manifestation is PPNAD. We then focused on clinically delineating the various types of primary bilateral adrenal hyperplasias (BAH). We described isolated micronodular adrenocortical disease (iMAD), a disorder likely to be inherited in an autosomal dominant manner and unrelated to the Carney complex or to other MENs. The identification of *PRKAR1A* mutations in PPNAD led to the recognition that non-pigmented forms of BAHs existed, and a new nomenclature was proposed, which we first suggested in 2008 and has since become used worldwide.

In 2006, a genome-wide association (GWA) study led to the identification of mutations in the phosphodiesterases (PDE) *PDE11A*, a dual specificity PDE, and *PDE8B*, a cAMP-specific PDE (encoded by the *PDE11A* and *PDE8B* genes, respectively) in iMAD. Following the establishment of cAMP/PKA involvement in PPNAD and iMAD, we and others found that elevated cAMP levels and/or PKA activity and abnormal PDE activity may be found in most benign adrenal tumors (ADTs), including the common adrenocortical adenoma (ADA). We then found *PDE11A* and *PDE8B* mutations or functional variants in adrenocortical cancer (ACA) and in other forms of adrenal hyperplasia such as massive macronodular adrenocortical disease (MMAD), also known as ACTH-independent adrenocortical hyperplasia (MMAD/AIMAH). Germline



**Constantine Stratakis, MD, D(med)Sci, Head, Section on Endocrinology and Genetics**

Maya Lodish, MD, *Staff Clinician*

Fabio Faucz, PhD, *Visiting Scientist*

Eva Szarek, BS, *Visiting Scientist*

Edra London, PhD, *Research Fellow*

Charalampos Lyssikatos, MD, *Research Associate*

Annabel Berthon, PhD, *Visiting Fellow*

Angela Dimopoulou, MD, *Visiting Fellow (DIPHR)*

Paraskevi Salpea, PhD, *Visiting Fellow*

Giampaolo Trivellin, PhD, *Visiting Fellow*

Margarita Raygada, PhD, *Genetic Counselor NICHD-NHGRI*

Elena Belyavskaya, MD, PhD, *Physician Assistant*

Mihail Zilbermint, MD, *Clinician Associate (Johns Hopkins University)*

Madelauz (Lucy) Sierra, MSc, *Research Assistant*

Jenna Shapiro, BS, *Graduate Student*

Smita Abraham (Baid), MD, *Volunteer (FDA)*

(continued)

*PDE11A* sequence variants may also predispose to testicular cancer (testicular germ cell tumors or TGCTs) and prostate cancer, indicating a wider role of this pathway in tumor formation on cAMP-responsive, steroidogenic, or related tissues. Ongoing work with collaborating NCI laboratories aims to clarify the role of PDE in predisposition to these tumors. It is clear from these data, however, that there is significant pleiotropy of *PDE11A* and *PDE8B* defects. The histo-morphological studies that we performed on human adrenocortical tissues from patients with these mutations showed that iMAD is highly heterogeneous and thus likely to be caused by defects in various genes of the cAMP/PKA signaling pathway or its regulators and/or downstream effectors.

Similarly, the G protein-coupled receptor (GPCR)-linked MMAD/AIMAH disease includes a range of adrenal phenotypes from very similar to iMAD to the *GNAS*-caused primary bimorphic adrenocortical disease (PBAD) and McCune-Albright syndrome, caused by somatic mutations of the *GNAS* gene (encoding the G protein-stimulatory subunit alpha or Gsa). Although a few of the patients with MMAD/AIMAH have germline *PDE11A*, *PDE8B*, or somatic *GNAS* mutations, others have germline fumarate hydratase (*FH*), menin (*MEN1*), and adenomatous polyposis coli (*APC*) mutations, pointing to the range of possibilities and the pathways that may be involved. Particularly interesting among these are *FH* mutations associated with mitochondrial oxidation defects that have been linked to adrenomedullary tumors. This led us to investigate a disorder known as the Carney Triad, the only known disease that has among its clinical manifestations both adrenocortical (ADA, MMAD/AIMAH) and medullary tumors (pheochromocytomas [PHEOs] and paragangliomas [PGLs]), in addition to hamartomatous lesions in various organs (pulmonary chondromas and pigmented and other skin lesions) and a predisposition to gastrointestinal stromal tumors or sarcomas (GISTs). A subgroup of patients with PHEOs, PGLs, and GISTs were identified as harboring mutations in succinate dehydrogenase (SDH) subunits B, C, and D (encoded by the *SDHB*, *SDHC*, and *SDHD* genes, respectively); the patients also rarely have adrenocortical lesions, ADAs, and/or hyperplasia, and their disease is known as the dyad or syndrome of PGLs and GISTs or, as named by a group of pathologists and now in wide use, the Carney-Stratakis syndrome (CSS).

In 2013, MMAD/AIMAH was renamed primary macronodular adrenocortical hyperplasia (PMAH) after it was discovered that it depends on adrenoglandular ACTH production, at least occasionally. As part of this work, a new gene was identified (*ARMC5*) that, when mutated, causes more than a third of the known PMAH cases. The function of the gene is unknown, and we have embarked on a project to characterize it further, including studying mouse, fruit fly, and fish models. The *ARMC5* gene has a beta-catenin-like motif.

Leticia Ferro Leal, BSc, *Graduate Student*  
Aaron Hodes, BSc, *Adjunct Researcher*  
Paola Chrysostomou, *Adjunct Researcher*  
Andreas Giannakou, MD, *Adjunct Researcher*  
Ludivine Drougat, PhD, *Visiting Fellow*  
Andrea Maria Gutierrez, BS, *Visiting Student (Brazil)*  
Fady Hannah-Shmouni, MD, *Clinical Associate (Endocrinology Fellow)*  
Laura Hernandez-Ramirez, MD, PhD, *Visiting Fellow*  
Nickolas Settas, PhD, *Visiting Fellow*  
Amit Tirosh, MD, *Contractor - Clinical Scientist (Israel)*  
Christina Tatsi, MD, *Clinical Associate (Pediatric Endocrinology Fellow)*  
Jennifer Gourgaris, MD, *Guest Researcher (Georgetown University faculty)*  
Flora Bacopoulou, MD, *Clinical Researcher on Sabbatical (Greece)*  
Pablo Beckers, MD, *Clinical Researcher on Rotation (Belgium)*  
Stephanie Espiard, MD, *Visiting Fellow on Grant (France)*  
Nuria Valdes Gallego, MD, *Clinical Researcher on Sabbatical (Spain)*  
Lloyd Tack, MD, *Visiting Clinician on Grant (Belgium)*  
Marianna Athanassiou, *Summer Student*  
Hailey Blain, *Summer Student*  
Rebecca Boden, *Summer Student*  
Christine Dedoulis, *Summer Student*  
Maria Faidas, *Summer Student*  
Mia Faulkner, *Summer Student*  
Eleanor Kimmelman, *Summer Student*  
Gregory Papaioannou, *Summer Student*  
Paulina Pedas, *Summer Student*



**SEGEN Laboratory Staff and Dr. Stratakis**

Our staff and Dr. Constantine Stratakis in March 2016 at our laboratory at the NIH CRC (1-East-3216)

PPNAD appears to be less heterogeneous and is mostly caused by *PRKAR1A* mutations, but up to one third of patients with the classic features of PPNAD do not have *PRKAR1A* mutations, deletions, or 17q22-24 copy-number variant (CNV) abnormalities. A subset of these patients may have defects in other molecules of the PKA holoenzyme, and their study is important for understanding how PKA works and the tissue specificity of each defect. For patients with disorders that are yet to be elucidated on a molecular level, we continue to delineate the phenotypes and identify the responsible genetic defects through a combination of genomic and transcriptomic analyses.

Recently, we identified genes encoding two other subunits of PKA as involved in endocrine tumors: *PRKACA* in BAH and *PRKACB* in a form of Carney complex that is not associated with *PRKAR1A* mutations. Our laboratory is now investigating these two genes.

Animal model studies are essential for the investigation and confirmation of each of the identified new genes in disease pathogenesis. Furthermore, such studies provide insight into function that can be tested quickly in human samples for confirmation of its relevance to human disease. One excellent example of such a bench-to-bedside (and back) process in the last review cycle was the identification, from a variety of animal experiments, of Wingless/int (Wnt) signaling as one of the downstream effectors of tumor formation in the context of increased cAMP/PKA activity. Both our laboratory and our collaborators found somatic beta-catenin (*CTNNB1*) mutations in large ADAs that formed in the background of PPNAD caused by germline *PRKAR1A* mutations. Our transcriptomic studies had previously identified the WNT1-inducible signaling pathway protein 2 (WISP2) as the main molecule overexpressed in food-dependent Cushing's syndrome caused by MMAD/AIMAH, and our recent micro-RNA studies showed that genes that regulate WNT



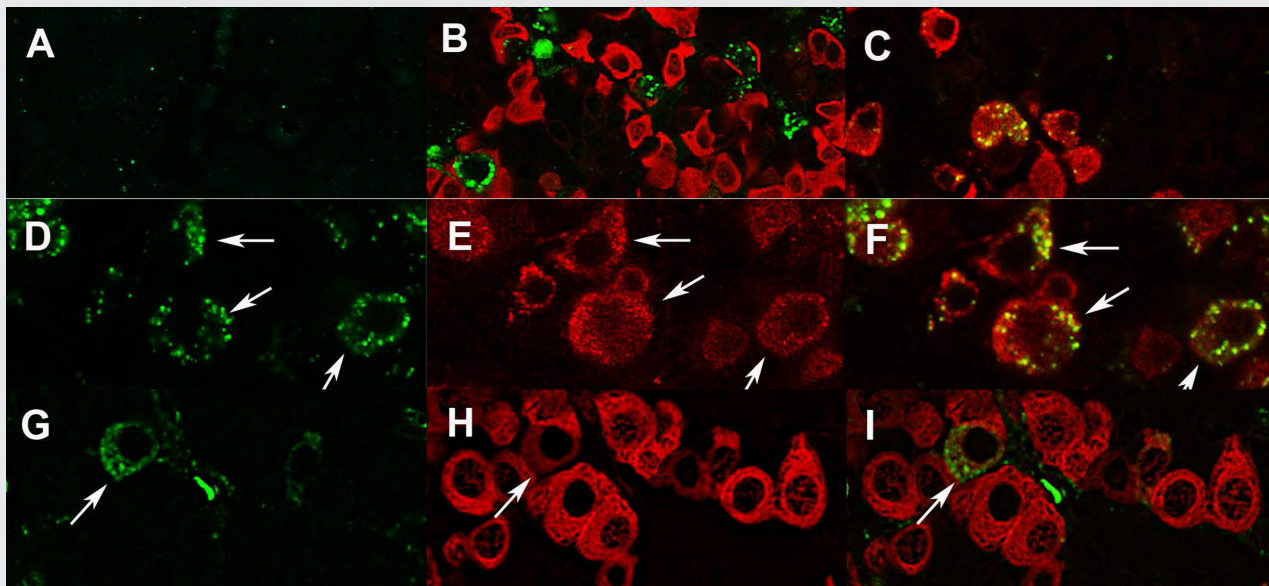

GPR101 expression in the pituitary and hypothalamus (Trivellini G *et al. J Mol Endocrinol* 2016;57:97–111)

Labeling of GPR101 in the anterior pituitary gland of female rhesus monkey (A–F) and rat (G–I).

(A) Preincubation of GPR101 antibody with blocking peptide, resulted in no staining.

(B) Punctuate GPR101 (*green*) labeling could not be attributed to somatotrophs (*red*).

(C) GPR101 (*green*) is expressed by LH $\beta$ -positive cells (*red*).

(D–F) High magnification images showing membranous and cytoplasmic distribution of GPR101 in monkey gonadotrophs, excluding nucleus.

(G–I) GPR101 (*green*) is expressed by subpopulation of rat somatotrophs (*red*), as indicated by arrows.

Scale bars: A–D: 20  $\mu$ m; E: 10  $\mu$ m

signaling were major targets of micro-RNAs, which were found dysregulated in both PPNAD and MMAD/AIMAH. Cells from tumors or other lesions from animals with R1a deficiency showed elevated beta-catenin expression and/or aberrant WNT signaling and similarities to adult stem cells or cancer stem cells in other models of dysregulated WNT signaling. However, it appears that beta-catenin activation in R1a-deficient cells is preceded by yet unknown molecular abnormalities that take place within the still benign and R1a-haploinsufficient tissues in the early stages of tumor formation.

We continue to investigate the pathways involved in early events in tumor formation in the adrenal cortex and/or the tissues affected by germline or somatic defects of the cAMP/PKA and related endocrine signaling defects, employing animal models and transcriptomic and systems-biology analyses. Understanding the role of the other PKA subunits in this process is essential. An example of the combined use of whole genomic tools, transcriptomic analysis, and mouse and zebrafish models to investigate the function of a gene or a pathway is the ongoing work on the Carney Triad.

An important discovery in the last 3–4 years was that mice with neural crest-, heart-, and adrenal-specific knockouts (KO) of R1a or mice with other R1a defects develop lesions caused by proliferation of stem cell-like, tissue-specific pluripotent cells (TSPCs) in adult tissues such as the adult skeleton. We studied bone and the

adrenal cortex. Given that various models of R1a deficiency appear to feature the growth of lesions derived from TSPCs, we are characterizing these cells in the adrenal and bone and creating laboratory conditions (i.e., culture systems) to propagate them *in vitro*, study their growth and proliferation, exploit their therapeutic potential, and/or identify molecules that affect the cells for targeting the related tumors in humans.

We continue to accrue patients under several clinical protocols, identify unique patients and families with rare phenotypes, and/or explore (mostly on a collaborative basis) various aspects of endocrine and related diseases. Paramount to these investigations is the availability of modern genetic tools such as copy number variation (CNV) analysis, comparative genomic hybridization (CGH), whole-exome sequencing (WES), and DNA sequencing (DSeq). As part of these clinical protocols, much clinical research is also being done, consisting mostly of observations of new associations, description of novel applications or modifications, and improvements in older diagnostic methods, tests, or imaging tools. This is a particularly fruitful area of research, especially for our clinical fellows who matriculate at our laboratory during their two-year research time. The approach also leads to important new discoveries that may steer us into new directions.

One such discovery was the recent identification by our laboratory of the defect that explains the vast majority of cases of early pediatric overgrowth or gigantism. What regulates growth, puberty, and appetite in children and adults is poorly understood. We identified the gene *GPR101*, encoding a G protein-coupled receptor, which was overexpressed in patients with elevated growth hormone (GH). Patients with *GPR101* defects have a condition that we called X-LAG for X-linked acrogigantism caused by Xq26.3 genomic duplication and characterized by early-onset gigantism resulting from excess GPR101 function and consequently elevated GH.

## Carney complex (CNC) genetics

We have collected families with CNC and related syndromes from several collaborating institutions worldwide. Through genetic linkage analysis, we identified loci harboring genes for CNC on chromosomes 2 (2p16) and 17 (17q22–24) and are currently searching for other possible loci for this genetically heterogeneous condition. With the application of state-of-the-art molecular cytogenetic techniques, we are investigating the participation of these currently identified genomic loci in the expression of the disease and have constructed a comprehensive genetic and physical map of the 2p16 chromosomal region for cloning the CNC-associated sequences from this region. Studies in cultured primary tumor cell lines (established from our patients) identified a region of genomic amplification in CNC tumors in the center of the map. The *PRKAR1A* gene on 17q22–24, the gene responsible for CNC in most cases of the disease, appears to undergo loss of heterozygosity in at least some CNC tumors. *PRKAR1A* is also the main regulatory subunit (subunit type 1-a) of PKA, a central signaling pathway for many cellular functions and hormonal responses. We have increased the number of CNC patients in genotype-phenotype correlation studies, which are expected to provide insight into the complex biochemical and molecular pathways regulated by *PRKAR1A* and PKA. We expect to identify new genes by ongoing genome-wide searches for patients and families who do not carry *PRKAR1A* mutations.

## *PRKAR1A*, protein kinase A activity, and endocrine and other tumor development

We are investigating the functional and genetic consequences of *PRKAR1A* mutations in cell lines established from CNC patients and their tumors. We measure both cAMP and PKA activity in the cell lines, along with the

expression of the other subunits of the PKA tetramer. In addition, we are seeking mutations of the *PRKAR1A* gene in sporadic endocrine and non-endocrine tumors (thyroid adenomas and carcinomas, adrenocortical adenomas and carcinomas, ovarian carcinomas, melanomas and other benign and malignant pigmented lesions, and myxomas in the heart and other sites)—mutations that would further establish the gene's role as a general tumor suppressor. Many investigators within the NIH and around the world provide specimens on a collaborative basis.

### *Prkar1a*<sup>+/-</sup> and related animal models

Several years ago we developed a *Prkar1a* knockout mouse floxed by a lox-P system for the purpose of generating, first, a novel *Prkar1a*<sup>+/-</sup> and, second, knockouts of the *Prkar1a* gene in a tissue-specific manner after crossing the new mouse model with mice expressing the cre protein in the adrenal cortex, anterior lobe of the pituitary, and thyroid gland (Kirschner *et al. Cancer Res* 2005;65:4506). The heterozygote mouse develops several tumors reminiscent of the equivalent human disease. We have now developed new crosses that show protein kinase A subunit involvement in additional phenotypes.

### PRKAR1A, the cell cycle, and other signaling pathways

We work to identify *PRKAR1A*-interacting mitogenic and other growth-signaling pathways in cell lines expressing *PRKAR1A* constructs and/or mutations. Several genes that regulate PKA function and increase cAMP-dependent proliferation and related signals may be altered in the process of endocrine tumorigenesis initiated by a mutant *PRKAR1A*, a gene with important functions in the cell cycle and in chromosomal stability. Recently, we found an interaction with the mTOR pathway in both human and mouse cells with altered PKA function.

### Phosphodiesterase (PDE) genes in endocrine and other tumors

In patients who did not exhibit CNC or have *PRKAR1A* mutations but presented with bilateral adrenal tumors similar to those in CNC, we found inactivating mutations of the *PDE11A* gene, which encodes phosphodiesterase-11A, an enzyme that regulates PKA in the normal physiologic state. Phosphodiesterase 11A is a member of a 22 gene-encoded family of proteins that break down cyclic nucleotides controlling PKA. *PDE11A* appears to act as a tumor suppressor such that tumors develop when its action is abolished. In what proved to be the first cases in which mutated PDE was observed in a genetic disorder predisposing to tumors, we found pediatric and adult patients with bilateral adrenal tumors. Recent data indicate that *PDE11A* sequence polymorphisms may be present in the general population. The finding that genetic alterations of such a major biochemical pathway may be associated with tumors in humans raises the reasonable hope that drugs that modify PKA and/or PDE activity may eventually be developed for use in both CNC patients and those with other, non-genetic, adrenal tumors—and perhaps other endocrine tumors.

After the identification of a patient with a *PDE8B* mutation and Cushing's syndrome, additional evidence emerged for yet another cAMP-specific PDE to be involved in endocrine conditions.

We also studied both *Pde11a* and *Pde8b* animal models.

### Genetic investigations into other adrenocortical diseases and related tumors

Through collaborations, we (1) apply general and pathway-specific microarrays to a variety of adrenocortical tumors, including single adenomas and MMAD, to identify genes with important functions in adrenal

oncogenetics; (2) examine candidate genes for their roles in adrenocortical tumors and development; and (3) identify additional genes that play a role in inherited pituitary, adrenocortical, and related diseases.

## Genetic investigations into pituitary tumors, X-LAG, other endocrine neoplasias, and related syndromes

In collaboration with several other investigators at the NIH and elsewhere, we are investigating the genetics of CNC- and adrenal-related endocrine tumors, including childhood pituitary tumors, related or unrelated to *PRKAR1A* mutations. As part of this work, we have identified novel genetic abnormalities.

We identified the gene *GPR101* encoding an orphan G protein-coupled receptor (GPCR), which was overexpressed in patients with elevated growth hormone (GH) or gigantism. Patients with *GPR101* defects have a condition that we called X-LAG, for X-linked acrogigantism, caused by Xq26.3 genomic duplication and characterized by early-onset gigantism resulting from excessive *GPR101* function and consequent GH excess. To find additional patients with this disorder, we collaborated with a group at the University of Liège headed by Albert Beckers, but all the molecular work for the gene identification was carried out here at the NIH. We have found that the gene is expressed in areas of the brain that regulate growth and we identified a few small-molecule compounds that bind to *GPR101* (unpublished). The data are now being used to identify more specific compounds that bind to *GPR101*.

## Genetic investigations into the Carney Triad, other endocrine neoplasias, and related syndromes and into hereditary paragangliomas and related conditions

As part of a collaboration with other investigators at the NIH and elsewhere (including an international consortium organized by our laboratory), we are studying the genetics of a rare syndrome that predisposes to adrenal and other tumors, the Carney Triad, and related conditions (associated with gastrointestinal stromal tumors, or GIST). In the course of our work, we identified a patient with a new syndrome, known as the paraganglioma and gastrointestinal stromal tumor syndrome (or the Carney-Stratakis syndrome), for which we found mutations in the genes encoding succinate dehydrogenase (SDH) subunits A, B, C, and D. In another patient, we found a novel germline mutation in the *PDGFRA* gene. Most recently, in collaboration with a group in Germany, we identified an epigenetic defect (methylation of the *SDHC* gene) that may be used diagnostically to identify patients with the Carney Triad.

## Clinical investigations into the diagnosis and treatment of adrenal and pituitary tumors

Patients with adrenal tumors and other types of Cushing's syndrome (and occasionally other pituitary tumors) come to the NIH Clinical Center for diagnosis and treatment. Ongoing investigations focus on (1) the prevalence of ectopic hormone receptor expression in adrenal adenomas and PMAH/MMAD; (2) the diagnostic use of high-sensitivity magnetic resonance imaging for earlier detection of pituitary tumors; and (3) the diagnosis, management, and post-operative care of children with Cushing's syndrome and other pituitary tumors.

## Clinical and molecular investigations into other pediatric genetic syndromes

Mostly in collaboration with several other investigators at the NIH and elsewhere, we are conducting work on pediatric genetic syndromes seen in our clinics and wards.

## Additional Funding

- INSERM, Paris, France (Co-Principal Investigator): “Clinical and molecular genetics of Carney complex,” 06/2003-present
- Several small grants supporting staff members from France, Brazil, Greece, Spain, and elsewhere

## Publications

1. Drelon C, Berthon A, Sahut-Barnola I, Mathieu M, Dumontet T, Rodriguez S, Batisse-Lignier M, Tabbal H, Tauveron I, Lefrançois-Martinez AM, Pointud JC, Gomez-Sanchez CE, Vainio S, Shan J, Sacco S, Schedl A, Stratakis CA, Martinez A, Val P. PKA inhibits WNT signalling in adrenal cortex zonation and prevents malignant tumour development. *Nat Commun* 2016 7:12751.
2. Bandettini WP, Karageorgiadis AS, Sinaii N, Rosing DR, Sachdev V, Schernthaner-Reiter MH, Gourgari E, Papadakis GZ, Keil MF, Lyssikatos C, Carney JA, Arai AE, Lodish M, Stratakis CA. Growth hormone and risk for cardiac tumors in Carney complex. *Endocr Relat Cancer* 2016 23:739-746.
3. Saloustros E, Liu S, Mertz EL, Bhattacharyya N, Starost MF, Salpea P, Nesterova M, Collins M, Leikin S, Stratakis CA. Celecoxib treatment of fibrous dysplasia (FD) in a human FD cell line and FD-like lesions in mice with protein kinase A (PKA) defects. *Mol Cell Endocrinol* 2016 439:165-174.
4. Gourgari E, Lodish M, Keil M, Sinaii N, Turkbey E, Lyssikatos C, Nesterova M, de la Luz Sierra M, Xekouki P, Khurana D, Ten S, Dobs A, Stratakis CA. Bilateral adrenal hyperplasia as a possible mechanism for hyperandrogenism in women with polycystic ovary syndrome. *J Clin Endocrinol Metab* 2016 101:3353-3360.
5. Trivellin G, Bjelobaba I, Daly AF, Larco DO, Palmeira L, Faucz FR, Thiry A, Leal LF, Rostomyan L, Quezado M, Schernthaner-Reiter MH, Janjic MM, Villa C, Wu TJ, Stojilkovic SS, Beckers A, Feldman B, Stratakis CA. Characterization of GPR101 transcript structure and expression patterns. *J Mol Endocrinol* 2016 57:97-111.

## Collaborators

- Albert Beckers, MD, *Université de Liège, Liège, Belgium*
- Jerome Bertherat, MD, PhD, *Service des Maladies Endocriniennes et Métaboliques, Hôpital Cochin, Paris, France*
- Stephan Bornstein, MD, PhD, *Universität Dresden, Dresden, Germany*
- Isabelle Bourdeau, MD, *Université de Montréal, Montreal, Canada*
- J. Aidan Carney, MD, PhD, *Mayo Clinic, Rochester, MN*
- Nickolas Courkoutsakis, MD, PhD, *University of Thrace, Alexandroupolis, Greece*
- Jennifer Gourgari, MD, *Georgetown University, Washington, DC*
- Margaret F. Keil, PhD, RN, CRNP, *Office of the Clinical Director, NICHD, Bethesda, MD*
- Lawrence Kirschner, MD, PhD, *James Cancer Hospital, Ohio State University, Columbus, OH*
- Andre Lacroix, MD, PhD, *Centre Hospitalier de l'Université de Montréal, Montreal, Canada*
- Giorgios Papadakis, MD, MPH, *Nuclear Medicine, Clinical Center, NIH, Bethesda, MD*
- Nickolas Patronas, MD, *Diagnostic Radiology, Clinical Center, NIH, Bethesda, MD*
- Margarita Rayada, PhD, *Office of the Clinical Director, NICHD, Bethesda, MD*

## Contact

For more information, email [stratak@mail.nih.gov](mailto:stratak@mail.nih.gov) or visit <http://segen.nichd.nih.gov>.

## Genetic and Environmental Determinants of Primate Biobehavioral Development

We investigate primate behavioral and biological development through comparative longitudinal studies of rhesus monkeys (*Macaca mulatta*) and other primates. Our primary goals are to characterize different distinctive bio-behavioral phenotypes in our rhesus monkey colony, determine how genetic and environmental factors interact to shape the developmental trajectories of each phenotype, and assess the long-term behavioral, biological, epigenetic, and health consequences for monkeys from various genetic backgrounds when they are reared in different physical and social environments. Another major program investigates how rhesus monkeys and other nonhuman primate species, born and raised under different laboratory conditions, adapt to placement in environments that contain specific physical and social features of their species' natural habitat. Adaptation is assessed by examining behavioral repertoires and by monitoring a variety of physiological systems in the subjects, yielding broad-based indices of relative physical and psychological health and well-being. The responses of subjects to experimental manipulation of selected features of their respective environments are also assessed in similar fashion. Whenever possible, we collect field data for appropriate comparisons. A major current focus is to investigate face-to-face interactions between mothers and infants during their initial days and weeks of life and to characterize the imitative capabilities of newborn infants and patterns of brain activity associated with imitative behavior. A second major focus is the study of cognitive and social behavioral development in capuchin monkeys (*Cebus apella*).

As in previous years, a major focus of this project was detailed longitudinal studies of the behavioral and biological consequences of differential early social rearing, most notably comparing rhesus monkey infants reared by their biological mothers in pens containing adult males and other mothers with same-age infants for their first 6–7 months of life (MR) with monkeys separated from their mothers at birth, hand-reared in the lab's neonatal nursery for their first month, and then raised in small groups of same-age peers for the next six months (PR), or housed in individual cages containing an inanimate surrogate mother and given two hours of daily interaction with similarly reared peers (SPR). At 7–8 months of age, MR, PR, and SPR infants are all moved into one large pen, where they live together



**Stephen J. Suomi, PhD, Head,**  
*Comparative Behavior Genetics  
Section*

Annika Paukner, PhD, *Senior  
Visiting Fellow*

Amanda M. Dettmer Erard, PhD,  
*Postdoctoral Fellow*

Angela M. Ruggiero, BS,  
*BioScience Laboratory Technician*

Kristen L. Byers, BS, *Contract  
Employee*

Michelle Miller, BS, *Contract  
Employee*

Ryan McNeil, BS,  
*Postbaccalaureate Fellow*

Ashley M. Murphy, BA,  
*Postbaccalaureate Fellow*

Lindsay P. Schwartz, BS,  
*Postbaccalaureate Fellow*

Emily Stonecker, BS,  
*Postbaccalaureate Fellow*

Lauren J. Wooddell, BS,  
*Postbaccalaureate Fellow*

until puberty. Thus, the differential social rearing occurs only for the first 7–8 months; thereafter MR, PR, and SPR share the same physical and social environment. We previously demonstrated that PR monkeys cling more, play less, tend to be more impulsive and aggressive, and exhibit much greater behavioral and biological disruption during and immediately following short-term social separation at six months of age than do MR monkeys. They also exhibit deficits in serotonin metabolism (as indexed by chronically low values of cerebrospinal fluid [CSF] 5-HIAA, the major serotonin metabolite), as do SPR monkeys. Additionally, they have significantly lower levels of 5-HTT (serotonin transporter) binding throughout many brain regions than do MR subjects. Many of these differences between MR and PR monkeys persist throughout the childhood years in the absence of experimental interventions. More recently, we published data extending these rearing condition differences to include patterns of brain lateralization, cortisol concentration in hair (a measure of chronic hypothalamic-pituitary-adrenal [HPA] activity), and measures of brain structure and function as assessed by structural MRI and positron emission tomography (PET), respectively. Additional differences in measures of social dominance status, maternal competence, telomere length, and physical health during childhood, adolescence, and adulthood were also documented. However, more recent studies indicated that many of these rearing condition differences in behavioral, biological, and health outcomes appear to be largely reversible following specific social interventions.

Another major focus of recent research for this project was to characterize interactions between differential early social rearing and polymorphisms in several candidate genes (G X E interactions), most notably the 5-HTTLPR polymorphic region of the *5-HTT* gene. During the past two years, we expanded the range of outcomes for which G x E interactions involving the 5-HTTLPR polymorphism and early rearing condition differences appear, including social play and behavioral reactions to a variety of social stressors, and in epigenetic regulation of brain activity. In addition, we recently reported significant G x E interactions between early MR vs. PR rearing and polymorphisms for several other candidate genes including: *DRD1*, which encodes the dopamine receptor D1; *NPY*, which encodes neuropeptide Y; *OPRM1*, which encodes the mu opioid receptor 1; *BDNF*, which encodes brain-derived neurotrophic factor; *NOS-1*, which encodes nitric oxide synthase 1 neuronal; and a single-nucleotide polymorphism (SNP) in the glucocorticoid gene, with outcome measures including play behavior, social buffering, behavioral and HPA reaction to an unfamiliar conspecific, naloxone treatment, alcohol consumption, and plasma BDNF concentrations. In virtually every case a similar pattern was observed, i.e., the less efficient (from a transcriptional point of view) allele was associated with a negative outcome among PR-reared monkeys but a neutral or, in some cases, even an optimal outcome for MR-reared subjects carrying that same less efficient allele, suggesting an overall buffering effect of MR rearing for individuals carrying these so-called risk alleles.

Additionally, we recently published the results of two sets of studies investigating the effects of differences in early social rearing (MR vs. SPR) on genome-wide patterns of mRNA expression in leukocytes and on methylation patterns in the prefrontal cortex (PFC) and in T cell lymphocytes. Our research involving mRNA expression, carried out in collaboration with Steven Cole and James Heckman, examined expression patterns in differentially reared 4-month-old infants. In all, 521 different genes were significantly more expressed in MR infants than in SPR infants, whereas the reverse was the case for another 717 genes. In general, SPR-reared infants showed enhanced expression of genes involved in inflammation, T lymphocyte activation and cell proliferation, and suppression of antiviral and antibacterial responses, a pattern curiously also seen in leukocyte expression in adult humans who perceive themselves as socially isolated. Since that initial study, we completed a prospective longitudinal study in which differentially reared subjects were

sampled at 14 days, 30 days, 6–7 months, and every three months thereafter until they reached puberty. Data analyzed to date revealed that the above rearing-condition differences in genome-wide patterns of mRNA expression in leukocytes persist throughout development in the absence of any changes in the social environment but change dramatically whenever the social environment is altered during the juvenile years.

The other set of studies, carried out in collaboration with Moshe Szyf and his lab, involved genome-wide analyses of methylation patterns in differentially reared monkeys when they were adults. The initial study compared such patterns in PFC tissue and T cell lymphocytes obtained from 8-year-old monkeys differentially reared for the first 6–7 weeks of life and thereafter maintained under identical conditions until adulthood. The analyses revealed that 1) more than 4,400 genes were differentially methylated in both the PFC and lymphocytes; 2) although there was considerable tissue specificity, approximately 25% of the affected genes were identical in both PFC and lymphocytes; and 3) in both PFC and lymphocytes, methylated promoters tended to cluster both by chromosomal region and gene function. This past year, we completed a prospective longitudinal study of genome-wide methylation patterns in lymphocytes, collecting samples from exactly the same MR and SPR monkeys at exactly the same time points as in the aforementioned longitudinal study of mRNA expression. Preliminary findings suggest that, at least in lymphocytes, extensive effects of rearing conditions are present within the first month of life but can subsequently be, at least in part, significantly minimized and/or re-directed following a social environmental intervention utilizing “foster” grandparents.

In another collaboration with the Szyf lab, we examined the epigenetic consequences of high vs. low ranking in established social groups of adult female monkeys and in offspring whose relative social dominance status matched that of their mothers. It appeared that the cross-generational transmission of social status was mediated, at least in part, by the placenta, in that the genome-wide pattern of methylation in tissues collected from placentas immediately after birth differed dramatically between offspring of high- and low-ranking females; not only did the order of magnitude of these differences match that of the above-mentioned early social rearing condition differences, but many of the same genes were involved, suggesting the existence of a subset of “early adversity” genes, i.e., genes sensitive to a range of different early life adversities.

Mothers interact emotionally with their newborns through exaggerated facial expressions and mutual gaze, a capacity that has long been considered uniquely human. We previously began a research program on early face-to-face interactions in rhesus monkeys after we made the serendipitous discovery that very young rhesus monkey infants did, in fact, engage in extensive face-to-face interactions with their mothers, but only during the first month of life. This past year, we further characterized face-to-face interactions between mothers and their newborn infants in a naturalistic setting. We found large individual variability in rates of maternal/infant face-to-face interactions, in that mothers who had only one or two infants engaged in mutual gazing/lip-smacking in the first 30 days of life significantly more than mothers who had had three or more infants, whereas the more experienced mothers let their infants out of arms’ reach significantly more in the first 30 days of life than newer mothers. Overall, mothers tended to engage in more face-to-face interactions with their male infants.

We also discovered that, during their first week, some (but not all) infants could accurately match certain facial gestures produced by a human experimenter, even after a delay. For those infants who could imitate



in this fashion, the capability was evident on the first postnatal day. We since investigated brain activity during periods of imitation using scalp electrodes to record EEG activity and found a distinctive EEG signature involving significant suppression of mu rhythm activity at low frequencies in frontal and parietal brain regions exclusively during periods of imitation. We reported that this pattern of EEG activity intensified through that first week and was significantly stronger in mother-reared than in nursery-reared neonates. The findings demonstrate similarities between infant human and infant monkey EEG during periods of imitation.

We also demonstrated, using eye-tracking technology, that week-old infants readily respond to a computer-generated dynamic monkey avatar, and that those infants who imitate tend to focus on different aspects of the avatar's face (eyes and mouth) compared with those that do not imitate (mouth only). We also compared neonatal imitation abilities in mother-reared and nursery-reared monkeys, focusing on day 3 performance only. We reported that, even though nursery-reared (NR) infants show an imitation effect when tested over the first week, they do not exhibit imitation specifically on day 3. In contrast, MR monkeys responded to facial gestures with more gestures themselves, consistent with our previous EEG findings that MR infants show larger mu suppression than NR infants when viewing facial gestures.

Given the potential impact of neonatal imitation on infants' social, cognitive, and emotional development, we devised one intervention whereby NR infants either received additional facial gesturing from a human caretaker, received additional handling (but did not see facial gestures), or remained in standard nursery rearing. We found that only the group that had received facial gesturing showed improved performance on the standard neonatal imitation task on day 7 as well as greater sensitivity to facial identity of others in a standardized stranger task. Infants from the facial gesturing group also showed increased preference for a social video at day 30 and again at day 40, had better memory for social stimuli when tested at day 60, and had higher levels of social contact with peers from day 40 to day 60 than did infants in the handling and standard rearing groups.

A second intervention designed to increase infants' social perception and social sensitivity looked at the effects of oxytocin on infants' social interactions. NR infants were nebulized with either oxytocin or saline and then tested in an imitation recognition task. We reported increased time spent looking at faces following oxytocin, but not saline, treatment. Salivary assays confirmed increased levels of oxytocin, and infants also showed more affiliative gesturing towards a human experimenter following oxytocin administration.

We further explored infants' facial processing strategies by presenting them with various faces and facial configurations on a remote eye tracker. Rhesus macaque infants generally prefer faces with normally arranged features over faces with linearly arranged features, suggesting a special sensitivity to faces and face-like stimuli. The preferences are particularly strong for faces of conspecifics, which suggests a genetic predisposition towards rhesus faces in particular. We also reported that neonatal imitators, but not non-imitators, exhibit particular sensitivities towards the eye region, which may indicate that neonatal imitation and differential social sensitivity are intricately linked.

A project begun last year involved the analysis of mothers' milk in rhesus monkeys with respect to parity and early life history (i.e., rearing condition). In collaboration with Katie Hinde, we collected milk samples from mothers over the first 30 days of their infant's life and analyzed the samples for cortisol content and

nutrient composition. Similar to Hinde's studies on human mothers' milk in older infants, we found that parity predicted milk yield volume (MYE) in the first month of life. Our findings also indicated that mothers with higher hair cortisol during pregnancy had a higher MYE in the first 30 days of life. Additionally, we found that cortisol levels in mothers' milk predicted infant cognitive functioning and social behavior later in life. Infants who ingested milk with higher cortisol content were less impulsive in a cognitive task but also initiated social behaviors with peers less frequently.

We used hair cortisol as a measure of chronic HPA activity in three additional studies completed this past year. First, hair cortisol levels measured shortly after birth, which presumably reflect prenatal HPA activity from mid-gestation onward, predicted cognitive performance capabilities and infant temperament in the first postnatal months. Second, changes in hair cortisol concentrations during the juvenile years predicted differences in social dominance status among adult female monkeys.

A third project centered on the incidence of alopecia and related physiological processes. We had previously observed that many females undergo severe hair loss during pregnancy, only to regain full hair growth in the two months postpartum. In collaboration with Melinda Novak and Jerrold Meyer, we examined the role of chronic HPA axis activity, as assessed by hair cortisol concentrations in alopecia. Our early results indicate that overall concentrations change across pregnancy and that monkeys that exhibit the greatest amount of hair loss have higher hair cortisol concentrations than those that do not.

We continued our research program on personality and facial characteristics with our capuchin monkeys, focusing on five personality dimensions (assertiveness, openness, neuroticism, sociability, and attentiveness), and found that the monkeys' facial width-to-height ratio, as well as their face width/lower face height, are positively and significantly associated with assertiveness. A lower face width/face height ratio was also associated with neuroticism. This past year, we also provided some of our capuchins with stone tools and observed for the first time in our colony spontaneous use of those tools to crack open walnuts. Nut-cracking has been observed in a few isolated wild populations of this species but is clearly far from universal. We plan to study its pattern of propagation in our captive colony, especially among juvenile and adolescent group members.

## Publications

1. Dettmer, AM, Rosenberg KL, Suomi SJ, Meyer JS, Novak MA. Associations between parity, hair hormone profiles during pregnancy and lactation, and infant development in rhesus monkeys (*Macaca mulatta*). *PLoS One* 2015 10:e0131692.
2. Paukner A, Simpson EA, Ferrari PF, Mrozek T, Suomi SJ. Neonatal imitation predicts how infants engage with faces. *Dev Sci* 2015 17:833-840.
3. Sclafani V, Paukner A, Suomi SJ, Ferrari PF. Imitation promotes affiliation in infant macaques at risk for impaired social behaviors. *Dev Sci* 2015 18:614-621.
4. Vanderwert RE, Simpson EA, Paukner A, Suomi SJ, Fox NA, Ferrari PF. Early social experience affects neural activity to affiliative facial gestures in newborn nonhuman primates. *Dev Neurosci* 2015 37:243-252.
5. Massert R, Nemoda Z, Sunderman MJ, Sutti S, Ruggiero AM, Dettmer AM, Suomi SJ, Szyf M. Early life adversity alters normal sex-dependent developmental dynamics of DNA methylation. *Dev Psychopathol* 2016 28(4pt2):1259-1272.

## Collaborators

- Enrico Alleva, MD, *Istituto Superiore di Sanità, Rome, Italy*
- Christina Barr, PhD, DVM, *Laboratory of Clinical Sciences, NIAAA, Bethesda, MD*
- Allyson J. Bennett, PhD, *University of Wisconsin-Madison, Madison, WI*
- Igor Brachi, PhD, *Istituto Superiore di Sanità, Rome, Italy*
- Sarah Brosnan, PhD, *Georgia State University, Atlanta, GA*
- Hannah Buchanan-Smith, PhD, *University of Stirling, Stirling, UK*
- Francesca Cirulli, PhD, *Istituto Superiore di Sanità, Rome, Italy*
- Steven W. Cole, PhD, *University of California Los Angeles, Los Angeles, CA*
- Jennifer Essler, MS, *Bucknell University, Lewisburg, PA*
- Pier F. Ferrari, PhD, *Università di Parma, Parma, Italy*
- Nathan A. Fox, PhD, *University of Maryland, College Park, MD*
- David Goldman, MD, *Laboratory of Neurogenetics, NIAAA, Bethesda, MD*
- James J. Heckman, PhD, *University of Chicago, Chicago, IL*
- Markus Heilig, MD, *Laboratory of Clinical Studies, NIAAA, Bethesda, MD*
- J.D. Higley, PhD, *Brigham Young University, Provo, UT*
- Katie Hinde, PhD, *Harvard University, Cambridge, MA*
- Stafano Kaburu, PhD, *University of California Davis, Davis, CA*
- Phyllis Lee, PhD, *University of Stirling, Stirling, UK*
- K. Peter Lesch, MD, *Universität Würzburg, Würzburg, Germany*
- Linda Mayes, MD, *Yale University, New Haven, CT*
- Jerrold S. Meyer, PhD, *University of Massachusetts, Amherst, MA*
- Eric Nelson, PhD, *Section on Development and Affective Neuroscience, NIMH, Bethesda, MD*
- Melinda A. Novak, PhD, *University of Massachusetts, Amherst, MA*
- Daniel A. Notterman, MD, PhD, *Princeton University, Princeton, NJ*
- Andreas Reif, PhD, *Universität Würzburg, Würzburg, Germany*
- David X. Reiss, MD, *Yale University, New Haven, CT*
- Helena Rutherford, PhD, *Yale University, New Haven, CT*
- Lisa M. Schneper, PhD, *Princeton University, Princeton, NJ*
- Melanie L. Schwandt, PhD, *Laboratory of Clinical and Translational Studies, NIAAA, Bethesda, MD*
- Valentina Sclafani, PhD, *Reading University, Reading UK*
- Alan Silberberg, PhD, *American University, Washington, DC*
- Elizabeth A. Simpson, PhD, *University of Miami, Miami, FL*
- Moshe Szyf, PhD, *McGill University, Montreal, Canada*
- Bernard Thierry, PhD, *Centre d'Écologie, Physiologie et Éthologie, CNRS, Strasbourg, France*
- Angelika Timme, PhD, *Freie Universität Berlin, Berlin, Germany*
- Ross E. Vanderwert, PhD, *Cardiff University, Cardiff, UK*
- Elisabetta Visalberghi, PhD, *Istituto de Scienze e Tecnologia della Cognizione, CNR, Rome, Italy*
- Alexander Weiss, PhD, *University of Edinburgh, Edinburgh, UK*
- Jane Widness, PhD, *Yale University, New Haven, CT*

## Contact

For more information, email [suomis@mail.nih.gov](mailto:suomis@mail.nih.gov) or visit [http://udn.nichd.nih.gov/brainatlas\\_home.html](http://udn.nichd.nih.gov/brainatlas_home.html).

## Development of the Vertebrate Circulatory System

The overall objective of this project is to understand how the elaborate networks of blood and lymphatic vessels arise during vertebrate embryogenesis. Blood vessels supply every tissue and organ with oxygen, nutrients, and cellular and humoral factors. Lymphatic vessels drain fluids and macromolecules from the interstitial spaces of tissues, returning them to the blood circulation, and play an important role in immune responses. Our studies on the formation of blood and lymphatic vessels are engendering intense clinical interest because of the roles both types of vessel play in cancer and ischemia. The zebrafish (*Danio rerio*) is a small tropical freshwater fish that possesses a unique combination of features that make it particularly suitable for studying vessel formation. Zebrafish are genetically tractable vertebrates with externally developing, optically clear embryos, which are readily available for observation and experimental manipulation. Such features make the fish highly advantageous for studying vascular development, permitting observation of every vessel in the living animal and simple, rapid screening for even subtle vascular-specific defects.

Current studies use genetic screening, experimental analysis, and imaging to examine cues directing vascular patterning and morphogenesis, regulation of vascular integrity, assembly of the lymphatic system, and hematopoietic stem cell formation.

### Tools for experimental analysis of vascular development in the zebrafish

The development of new tools to facilitate vascular studies in the zebrafish is an important ongoing aim of our work. Previously, we (1) established a micro-angiographic method for imaging patent blood vessels in the zebrafish and used the method to compile a comprehensive staged atlas of the vascular anatomy of the developing fish (<http://zfish.nichd.nih.gov>); (2) generated a variety of transgenic zebrafish lines expressing various fluorescent proteins within vascular or lymphatic endothelial cells, making it possible for us to visualize vessel formation in intact, living embryos; and (3) developed methodologies for long-term multiphoton confocal time-lapse imaging of vascular development in transgenic fish. Recent technical advances have greatly facilitated the generation



**Brant M. Weinstein, PhD,**  
*Head, Section on Vertebrate  
Organogenesis*

Aniket Gore, PhD, *Staff Scientist*

Matthew Butler, PhD, *Postdoctoral  
Fellow*

Marina Venero Galanternik, PhD,  
*Postdoctoral Fellow*

Hyun Min Jung, PhD, *Postdoctoral  
Fellow*

Shlomo Krispin, PhD, *Postdoctoral  
Fellow*

Mayumi Miller, PhD, *Postdoctoral  
Fellow*

Amber Stratman, PhD,  
*Postdoctoral Fellow*

Margaret Burns, BS,  
*Postbaccalaureate Fellow*

Olivia Farrelly, BS,  
*Postbaccalaureate Fellow*

Chase Melick, BS,  
*Postbaccalaureate Fellow*

Van Pham, BS, *Scientific Technician*

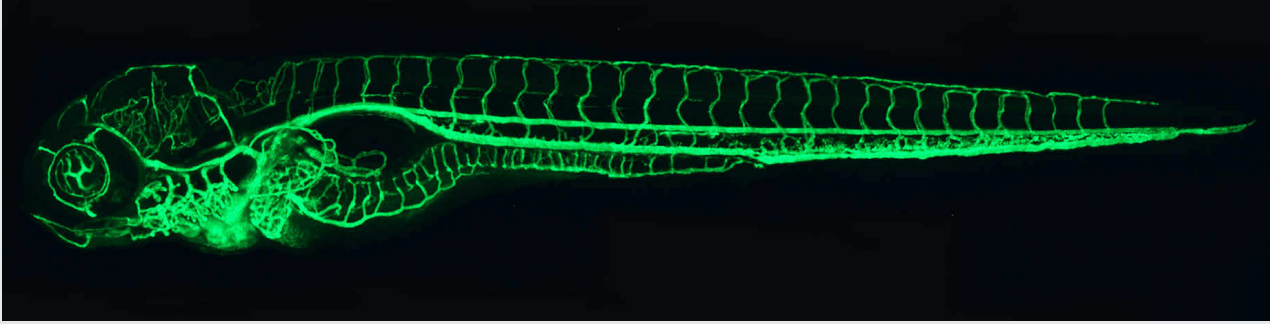

**FIGURE 1. The zebrafish vascular system**

Confocal micro-angiogram of the vascular system of a 4½-day-old zebrafish larva labeled by injecting fluorescent microspheres. The transparency of zebrafish larvae makes it possible to use high-resolution optical imaging methods to visualize the entire vasculature in exquisite detail.

of new transgenic lines, and we are currently developing many new lines useful for *in vivo* vascular imaging as well as for *in vivo* endothelial-specific profiling and functional manipulation of signaling pathways involved in vascular specification, patterning, and morphogenesis. Furthermore, we are taking advantage of recently developed CRISPR (clustered regularly interspaced short palindromic repeats) gene-editing technology to easily generate germline mutations in any zebrafish gene of interest. We are also in the process of generating a detailed staged anatomical atlas of the developing lymphatic system in the zebrafish comparable to the atlas of the circulatory system that we had published previously.

## Genetic analysis of vascular development

We use forward-genetic approaches to identify and characterize new zebrafish mutants that affect the formation of the developing vasculature. Using transgenic zebrafish expressing green fluorescent protein (GFP) in blood vessels (Figure 1) or lymphatic vessels, we are carrying out ongoing large-scale genetic screens for mutants induced by *N*-ethyl-*N*-nitrosourea (ENU). We have already identified hundreds of new vascular mutants with phenotypes that include loss of most vessels or subsets of vessels, increased sprouting/branching, and vessel mis-patterning. We recently carried out a new genetic screen to identify hemorrhagic stroke-susceptibility genes. We are currently using lymphatic-specific transgenic lines to perform screens for mutants specifically affecting the development of lymphatic vessels. We are pursuing the molecular cloning of the defective genes from all our new mutants, using next-generation whole-exome sequencing. To facilitate identification of the causative mutations (as opposed to naturally occurring polymorphisms) in our next-generation sequencing (NGS) data, we generated a large database of naturally occurring SNP (single nucleotide polymorphism) variants in three commonly used laboratory zebrafish strains. We also developed a web-based tool (“SNPfisher”) to facilitate querying and manipulating the database. Whole-exome sequencing combined with our SNP identification tools has already made it possible to rapidly identify the causative mutations in some of our more recently identified mutants. The identification of additional defective genes from our mutants should result in further new insights into the molecular mechanisms underlying vascular development and vascular integrity. Together, our ongoing mutant screens continue to yield a rich harvest of novel vascular mutants and genes, bringing to light new pathways that are critical during vascular development and vascular disease.

## Analysis of vascular morphogenesis and integrity

Proper morphogenesis of vascular tubes and the maintenance of their integrity is of critical importance to human health. Malformation or rupture of vessels is the basis for stroke, the third leading cause of death and the most common cause of disability in developed nations. Intracerebral hemorrhage (ICH) accounts for 10 percent of stroke and is a particularly severe form of the disease, with disproportionately high rates of death and long-term disability. Therapeutic tools are still very limited, and prevention remains the most important way to reduce morbidity and mortality. In previous studies, we used high-resolution time-lapse two-photon imaging to examine vessel morphogenesis in

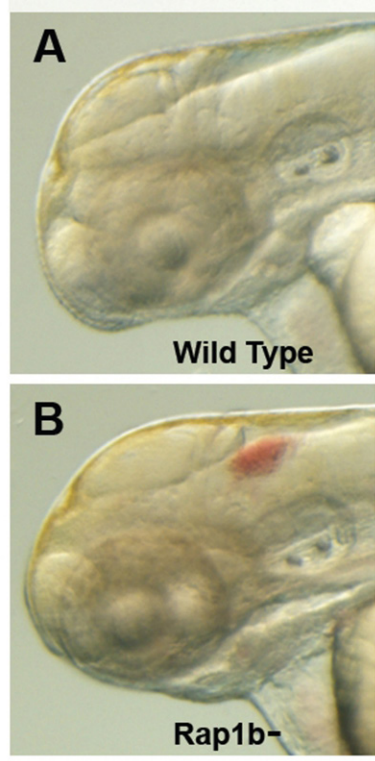

**FIGURE 2. Intracranial hemorrhage (ICH) in the developing zebrafish**

The clarity of zebrafish larvae also makes it straightforward to screen for animals with intracranial hemorrhage, as is evident in comparing lateral views of a 2-day-old wild-type larva (A) with a hemorrhage-prone larva deficient in *rap1b* (B).

living zebrafish, showing that the formation and intra- and intercellular fusion of endothelial vacuoles drive vascular lumen formation *in vivo*. We are currently examining the formation and maintenance of vascular endothelial cell-cell junctions, which are particularly important in stroke. To begin dissecting the molecular-regulatory mechanisms controlling endothelial junction formation, we examined a variety of genes required for vascular morphogenesis and vascular integrity, including the *ccm*, *pak2a*, and *rap1b* genes (see Figure 2 for the effects of *rap1b* disruption). We are also developing transgenic lines that permit us to visualize the dynamics of endothelial cell-cell junctions and intracellular cytoskeletal structures in order to examine their role in the cellular rearrangements that occur during vascular sprouting and growth and vascular tube formation. As noted above, we also carried out a genetic screen for genes that increase susceptibility to ICH. The screen identified many new mutants that elevate the propensity for ICH. Whole-exome NGS of the mutants is leading to the identification of novel genetic modifiers of the onset and severity of hemorrhagic stroke and, potentially, to the development of new therapeutic targets for the treatment and prevention of human ICH.

## Analysis of vascular patterning

We used multiphoton time-lapse imaging to characterize patterns of vessel assembly throughout the developing zebrafish. Our ongoing studies aim to understand how the patterns arise and what cues guide vascular network assembly during development. We previously demonstrated that known neuronal guidance factors play an important, previously unknown role in vascular guidance and vascular patterning, showing that semaphorin signaling is an essential determinant of trunk blood-vessel patterning (Figure 3). More recently, we also showed that chemokine signaling orchestrates the assembly and patterning of the

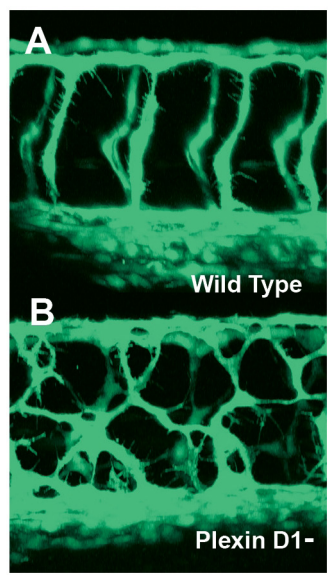

**FIGURE 3. Mis-patterned trunk vessels in larvae lacking the vascular semaphorin receptor plexin D1**

Confocal imaging of trunk vessels in a 2½-day-old wild-type (A) and a plexin D1-deficient (B) larva, showing loss of proper patterning of the trunk vessels caused by inability to receive semaphorin repulsive guidance signals.

developing lymphatic vasculature of the trunk. Current studies are elucidating the role of additional factors that guide the patterning of developing blood and lymphatic vascular networks *in vivo*, both in the trunk and in vascular beds in the eye, aortic arches, hindbrain, and other anatomical locales.

### Analysis of lymphatic development

The lymphatic system has become the subject of great interest in recent years because of the recognition of its important role in normal and pathological processes, but progress in understanding the

origins and early development of the system has been hampered by difficulties in observing lymphatic cells *in vivo* and performing defined genetic and experimental manipulation of the lymphatic system in currently available model organisms. We recently demonstrated that the zebrafish possesses a lymphatic system that shares many of the morphological, molecular, and functional characteristics of lymphatic vessels found in other vertebrates, thus providing a powerful new model for imaging and studying lymphatic development. As we continue to examine the origins and assembly of the lymphatic system of the zebrafish, we are developing new transgenic tools for imaging the development of the lymphatic system and for forward-genetic screening for lymphatic mutants. Our genetic analysis has already identified several novel genes involved in lymphatic development and patterning. We are also studying the roles of numerous different genes required for specification, assembly, or patterning of the lymphatic endothelium, including a role for chemokine signaling in guidance and patterning of lymphatic vessel assembly in the developing larval trunk. We have also been studying a novel lymphatic-related perivascular cell population that plays a supportive role in the brain. Our ongoing studies will thus provide new insights into the molecular regulation of lymphatic development.

### Epigenetic regulation of hematopoietic stem and progenitor cell emergence

We recently discovered a novel mechanism for epigenetic regulation of hematopoietic stem and progenitor cell (HSPC) specification. HSPCs emerge from the ventral wall of the dorsal aorta in all vertebrates. We found that a gene encoding DNA methyltransferase 3bb.1 (*dnmt3bb.1*) is expressed specifically in the ventral aortic endothelium, which gives rise to HSPCs. The gene functions downstream from a previously described genetic pathway for specification of HSPCs to promote the long-term maintenance of hematopoietic cell fate. Loss of the *dnmt3bb.1* gene *in vivo* results in loss of HSPCs, while early ectopic overexpression of the *dnmt* gene is sufficient to induce ectopic hematopoietic gene expression. We are currently continuing to study the role of *dnmt3bb.1* and DNA methylation in development and disease.

## Publications

1. Castranova D, Davis AE, Lo BD, Miller MF, Paukstelis PJ, Swift MR, Pham VN, Torres-Vázquez J, Bell K, Shaw KM, Kamei M, Weinstein BM. Aminoacyl tRNA synthetase deficiency up-regulates angiogenesis via the unfolded protein response pathway. *Arterioscler Thromb Vasc Biol* 2016 36:655-662.
2. Gore AV, Athans B, Iben JR, Johnson K, Russanova V, Castranova D, Pham VN, Butler MG, Williams-Simons L, Nichols JT, Bresciani E, Feldman B, Kimmel C, Liu PP, Weinstein BM. Epigenetic regulation of hematopoiesis by DNA methylation. *eLife* 2016 5:e11813.
3. Moore JC, Mulligan T, Yordán NT, Castranova D, Pham VN, Tang Q, Lobbardi R, Anselmo A, Liwski RS, Berman JN, Sadreyev RI, Weinstein BM, Langenau DM. T-cell immune deficiency in zap70 mutant zebrafish. *Mol Cell Biol* 2016; Epub ahead of print.
4. Nohata N, Uchida Y, Stratman A, Adam RH, Zheng Y, Weinstein BM, Mukoyama Y, Gutkind JS. Temporal-specific roles of Rac1 during vascular development and retinal angiogenesis. *Dev Biol* 2016 411:183-194.
5. Ulrich F, Carretero-Ortega J, Menéndez J, Sun B, Lancaster E, Pershad V, Trzaska S, Véliz E, Narvaez C, Kamei M, Prendergast A, Kidd KR, Shaw KM, Castranova DA, Pham VN, Lo BD, Martin BL, Raible DW, Weinstein BM, Torres-Vázquez J. Reck enables cerebral vascular development by promoting Wnt/beta-catenin and VEGF signaling. *Development* 2016 143:147-159.

## Collaborators

- George Davis, PhD, *University of Missouri-Columbia, Columbia, MO*
- Elisabetta Dejana, PhD, *The FIRC Institute of Molecular Oncology Foundation, Milan, Italy*
- Louis Dye, BS, *Microscopy and Imaging Core, NICHD, Bethesda, MD*
- Michael Granato, PhD, *University of Pennsylvania, Philadelphia, PA*
- Silvio Gutkind, PhD, *Oral and Pharyngeal Cancer Branch, NIDCR, Bethesda, MD*
- Jiro Hitomi, MD, *Iwate Medical University, Morioka, Japan*
- James Iben, PhD, *Molecular Genomics Laboratory, NICHD, Bethesda, MD*
- Sumio Isogai, PhD, *Iwate Medical University, Morioka, Japan*
- Paul Liu, MD, PhD, *Genetics and Molecular Biology Branch, NHGRI, Bethesda, MD*
- Joan Marini, MD, PhD, *Section on Heritable Disorders of Bone and Extracellular Matrix, NICHD, Bethesda, MD*
- Yoh-suke Mukoyama, PhD, *Laboratory of Stem Cell and Neuro-Vascular Biology, NHLBI, Bethesda, MD*
- Xuetao Pei, MD, PhD, *Beijing Institute of Transfusion Medicine, Beijing, China*
- Valya R. Russanova, PhD, *Section on Chromatin and Gene Expression, NICHD, Bethesda, MD*
- Zhaoxia Sun, PhD, *Yale University School of Medicine, New Haven, CT*
- Elizabeth Tournier-Lasserre, PhD, *INSERM (Hôpital Lariboisière), Paris, France*

## Contact

For more information, email [weinsteb@mail.nih.gov](mailto:weinsteb@mail.nih.gov) or visit <http://uvo.nichd.nih.gov>.



## Studies on DNA Replication, Repair, and Mutagenesis in Eukaryotic and Prokaryotic Cells

Under optimal conditions, the fidelity of DNA replication is extremely high. Indeed, it is estimated that, on average, only one error occurs for every 10 billion bases replicated. However, given that living organisms are continually subjected to a variety of endogenous and exogenous DNA-damaging agents, optimal conditions rarely prevail *in vivo*. While all organisms have evolved elaborate repair pathways to deal with such damage, the pathways rarely operate with 100% efficiency. Thus, persisting DNA lesions are replicated, but with much lower fidelity than in undamaged DNA. Our aim is to understand the molecular mechanisms by which mutations are introduced into damaged DNA. The process, commonly referred to as translesion DNA synthesis (TLS), is facilitated by one or more members of the Y-family of DNA polymerases, which are conserved from bacteria to humans. Based on phylogenetic relationships, Y-family polymerases may be broadly classified into five subfamilies: DinB-like (polIV/ pol kappa-like) proteins are ubiquitous and found in all domains of life; in contrast, the Rev1-like, Rad30A (pol eta)-like, and Rad30B (pol iota)-like polymerases are found only in eukaryotes; and the UmuC (polV)-like polymerases only in prokaryotes. We continue to investigate TLS in all three domains of life: bacteria, archaea, and eukaryotes.

### Prokaryotic DNA repair and mutagenesis

Most damage-induced mutagenesis in *Escherichia coli* is dependent upon the Umu<sub>2</sub>C protein complex, which comprises DNA polymerase V (polV). The polymerase lacks 3' to 5' exonucleolytic proofreading activity and is inherently error-prone when replicating both undamaged and damage DNA. So as to limit any "gratuitous" mutagenesis, the activity of polV is strictly regulated in the cell at multiple levels (Reference 1, 2). The first is transcriptional control. Like all genes expressed as part of the damage-inducible "SOS response," the *umuDC* locus is negatively regulated by the LexA transcriptional repressor, which binds to a near-consensus binding site immediately upstream of the operon. As a consequence, the UmuDC proteins are induced late in the SOS response. Indeed, they are not fully derepressed until about 15 minutes after cells have been exposed to DNA damage, and significant levels of the Umu proteins do not accumulate until approximately 45 minutes after DNA damage. Levels



**Roger Woodgate, PhD, Chief,**  
*Section on DNA Replication,  
Repair, and Mutagenesis*

Ekaterina Chumakov, PhD, *Staff  
Scientist*

Alexandra Vaisman, PhD,  
*Interdisciplinary Scientist*

John McDonald, PhD, *Biologist*

Mary McLenigan, BS, *Chemist*

Ewa Grabowska, PhD,  
*Postdoctoral Visiting Fellow*

In Soo Jung, PhD, *Postdoctoral  
Visiting Fellow*

Ashley Swanson, PhD,  
*Postdoctoral Intramural  
Research Training Award Fellow*

Erin Walsh, PhD, *Postdoctoral  
Intramural Research Training  
Award Fellow*

Donald Huston, BS, *Technical  
Intramural Research Training  
Award Trainee*

David Wilson, BS,  
*Postbaccalaureate Intramural  
Research Training Award Fellow*

of UmuD and UmuC are further kept to a minimum through their targeted proteolysis by the ATP-dependent protease Lon. Even when expressed, the homodimeric UmuD protein is considered to be mutagenically inactive and has to undergo a RecA-mediated self-cleavage reaction that removes its N-terminal 24 amino acids, thereby converting UmuD into the mutagenically active UmuD' protein. The cleavage reaction is inefficient and results in the formation of heterodimeric UmuD/UmuD'. Within the context of the heterodimer, UmuD' is subject to rapid proteolysis by the ClpXP protease, such that homodimeric UmuD' only accumulates in the presence of continued DNA damage. As a result, formation of UmuD'<sub>2</sub>C (polV) only occurs in the presence of persistent cellular DNA damage. Biochemical studies revealed that polV has intrinsically weak catalytic activity, but this activity is dramatically stimulated by interactions with ATP and RecA to form a higher-order complex termed polV Mut. The activity of polV Mut is further enhanced through protein-protein interactions with the beta-sliding clamp and Single-Stranded Binding (SSB) protein. It is evident that numerous and complex levels of regulation have therefore been imposed on polV, so as to apparently limit its highly mutagenic functions within the cell. However, a low level of mutagenesis is beneficial, because it provides genetic diversity and may contribute to overall evolutionary fitness. Indeed, *E.coli* appears to utilize the various polV regulatory pathways to provide “just the right amount” of polV in times of stress, so as to help the organism overcome environmentally challenging adversity.

## Eukaryotic DNA repair and mutagenesis

Our studies on the eukaryotic TLS polymerases focused on human DNA polymerases (pols) eta and iota. Both are Y-family DNA polymerase paralogs that facilitate translesion synthesis (TLS) past damaged DNA. Like *E. coli* polV, the activity of pols eta and iota can be modulated through post-translational modifications. Indeed, both pol eta and pol iota can be monoubiquitinated *in vivo*. Pol eta has previously been shown to be ubiquitinated at one primary site. When this site is unavailable, three nearby lysines may become ubiquitinated. In contrast, mass-spectrometry analysis of monoubiquitinated pol iota revealed that it is ubiquitinated at over 27 unique sites (Reference 3). Many of these sites are located in different functional domains of the protein, including the catalytic polymerase domain, the PCNA-interacting region, the Rev1-interacting region, as well as its Ubiquitin Binding Motifs, UBM1 and UBM2. Pol iota monoubiquitination remained unchanged after cells were exposed to DNA-damaging agents such as UV light (generating UV photoproducts), ethyl methanesulfonate (generating alkylation damage), mitomycin C (generating interstrand crosslinks), or potassium bromate (generating direct oxidative DNA damage). However, when exposed to naphthoquinones, such as menadione and plumbagin, which cause indirect oxidative damage through mitochondrial dysfunction, pol iota becomes transiently polyubiquitinated via K11- and K48-linked chains of ubiquitin and subsequently targeted for degradation. Polyubiquitination does not occur as a direct result of the perturbation of the redox cycle, given that no polyubiquitination was observed after treatment with rotenone or antimycin A, which inhibit mitochondrial electron transport. Interestingly, polyubiquitination was observed after the inhibition of the lysine acetyltransferase KAT5/p300. We hypothesized that the formation of polyubiquitination chains attached to pol iota occurs via the interplay between lysine acetylation and ubiquitination of ubiquitin itself at K11 and K48 rather than oxidative damage *per se*.

As part of a collaborative study with Patricia Gearhart, we also investigated the role that pol iota plays in the somatic hypermutation of antibody genes (Reference 4). Pol iota is an attractive candidate for somatic hypermutation in antibody genes because of its low fidelity. To identify a role for pol iota, we analyzed mutations in two strains of mice with deficiencies in the enzyme: 129X1/SvJ mice with negligible expression of truncated pol iota; and knock-in mice that express full-length pol iota that is catalytically inactive. Both

strains had normal frequencies and spectra of mutations in the variable region, indicating that loss of pol iota did not change overall mutagenesis. We next examined whether pol iota affected tandem mutations generated by another error-prone polymerase, pol zeta. We analyzed the frequency of contiguous mutations using a novel computational model to determine whether they occur during a single DNA transaction or during two independent events. Analyses of 2,000 mutations from both strains indicated that pol iota-compromised mice lost the tandem signature, whereas C57BL/6 mice accumulated significant amounts of double mutations. The results therefore support a model in which pol iota occasionally accesses the replication fork to generate a first mutation, and pol zeta extends the mismatch with a second mutation.

## Additional Funding

- Collaborative extramural U01 grant (U01HD085531-01) with Prof. Digby Warner, University of Cape Town, South Africa: Replisome dynamics in *M. tuberculosis*: linking persistence to genetic resistance

## Publications

1. Goodman MF, McDonald JP, Jaszczur MM, Woodgate R. Insights into the complex levels of regulation imposed on *Escherichia coli* DNA polymerase V. *DNA Repair* 2016 44:42-50.
2. Jaszczur M, Bertram JG, Robinson A, van Oijen AM, Woodgate R, Cox MM, Goodman MF. Mutations for worse or better: low-fidelity DNA synthesis by SOS DNA polymerase V is a tightly regulated double-edged sword. *Biochemistry* 2016 55:2309-2318.
3. McIntyre J, McLenigan MP, Frank EG, Dai X, Yang W, Wang Y, Woodgate R. Posttranslational regulation of human DNA polymerase iota. *J Biol Chem* 2015 290:27332-27344.
4. Maul RW, MacCarthy T, Frank EG, Donigan KA, McLenigan MP, Yang W, Saribasak H, Huston DE, Lange SS, Woodgate R, Gearhart PJ. DNA polymerase iota functions in the generation of tandem mutations during somatic hypermutation of antibody genes. *J Exp Med* 2016 213:1675-1683.

## Collaborators

- Michael Cox, PhD, *University of Wisconsin, Madison, WI*
- Patricia J. Gearhart, PhD, *Laboratory of Molecular Biology and Immunology, NIA, Baltimore, MD*
- Myron F. Goodman, PhD, *University of Southern California, Los Angeles, CA*
- Andrew Robinson, PhD, *University of Wollongong, Wollongong, Australia*
- Anton Simeonov, PhD, *Scientific Director, NCATS, Bethesda, MD*
- Antoine Van Oijen, PhD, *University of Wollongong, Wollongong, Australia*
- Yinsheng Wang, PhD, *University of California, Riverside, CA*
- Digby Warner, PhD, *University of Cape Town, Cape Town, South Africa*
- Wei Yang, PhD, *Laboratory of Molecular Biology, NIDDK, Bethesda, MD*

## Contact

For more information, email [woodgate@nih.gov](mailto:woodgate@nih.gov) or visit <http://sdrmm.nichd.nih.gov>.

## Physiology, Psychology, and Genetics of Obesity

The prevalence of overweight and obesity in children and adults has tripled during the past 40 years. The alarming rise in body weight has likely occurred because the current environment affords easy access to calorie-dense foods and requires less voluntary energy expenditure. However, such an environment leads to obesity only in those individuals whose body weight-regulatory systems are not able to control body adiposity with sufficient precision in our high calorie/low activity environment, which suggests there are subgroups in the U.S. with a uniquely high susceptibility to weight gain under the prevailing environmental conditions. Our primary goal is to elucidate the genetic underpinnings of the metabolic and behavioral endophenotypes that contribute to the development of obesity in children. Using our unique longitudinal cohorts of children at risk for adult obesity, who have undergone intensive metabolic and behavioral phenotyping, we examine genetic and phenotypic factors predictive of progression to adult obesity in children who are in the 'pre-obese' state, allowing characterization of phenotypes unconfounded by the impact of obesity itself. Once they are identified as linked to obesity, we study intensively genetic variants that impair gene function. We expect that these approaches will improve our ability to predict which children are at greatest risk for obesity and its comorbid conditions and will lead to more targeted, etiology-based prevention and treatment strategies for pediatric obesity.

### Genetic factors important for childhood body weight regulation

To identify gene variants affecting body composition, we have been examining polymorphisms in genes involved in the leptin signaling pathway. Genes include the leptin receptor (*LEPR*), *FTO* (fat mass and obesity-associated gene), and those encoding pro-opiomelanocortin (*POMC*), the melanocortin 3 receptor (*MC3R*), the melanocortin 4 receptor (*MC4R*), and brain-derived neurotrophic factor (*BDNF*). We are currently studying a variant *MC3R* that is associated with adiposity in children and appears to have functional significance for *MC3R* signal transduction. Children who are homozygous variant for both C17A and G241A polymorphisms have significantly greater fat mass and higher plasma levels of insulin and leptin than unaffected or heterozygous children and appear to eat more at



**Jack A. Yanovski, MD, PhD, Head,**  
*Section on Growth and Obesity*

Joo Yun Jun, PhD, *Postdoctoral Fellow*

Miranda Broadney, MD, MPH,  
*Pediatric Endocrine Training Program Fellow*

Ovidiu Galescu, MD, *Pediatric Endocrine Training Program Fellow*

Britni R. Belcher, PhD, *Special Volunteer*

Nichole Kelly, PhD, *Special Volunteer*

Rachel Miller-Radin, MA, *Special Volunteer*

Natasha A. Schvey, PhD, *Special Volunteer*

Lisa Shank, MA, *Special Volunteer*

Sheila M. Brady, RN, FNP, *Nurse Practitioner*

Robin Roberson, MS, *Technician*

Ira S. Tigner, MS, *Technical Intramural Research Training Award Fellow*

Dezmond Taylor-Douglas, BS, *Graduate Student*

*(continued)*

laboratory test meals (Figure 1). *In vitro* studies subsequently found that signal transduction and protein expression were significantly lower for the double-mutant *MC3R*. Our ongoing studies attempt to understand the mechanisms by which these sequence alterations may affect body weight. We therefore developed transgenic 'knock-in' mice expressing the human wild-type and human double-mutant *MC3R*. Using homozygous knock-in mouse models replacing murine *Mc3r* with wild-type human (*MC3R<sup>hWT/hWT</sup>*) and double-mutant (C17A+G241A) human (*MC3R<sup>hDM/hDM</sup>*) *MC3R*, we found that *MC3R<sup>hDM/hDM</sup>* have greater weight and fat mass (Figure 2), elevated energy intake and feeding efficiency, but lower length and fat-free mass than *MC3R<sup>hWT/hWT</sup>* (Reference 1). *MC3R<sup>hDM/hDM</sup>* mice do not exhibit increased adipose tissue inflammatory cell infiltration or greater expression of inflammatory markers despite their greater fat mass. Serum adiponectin is elevated in *MC3R<sup>hDM/hDM</sup>* mice and *MC3R<sup>hDM/hDM</sup>* human subjects (Figure 2). *MC3R<sup>hDM/hDM</sup>* bone- and adipose tissue-derived mesenchymal stem cells (MSCs) differentiate into adipocytes that accumulate more triglyceride than *MC3R<sup>hWT/hWT</sup>* MSCs. *MC3R<sup>hDM/hDM</sup>* thus impacts nutrient partitioning to generate increased adipose tissue that appears metabolically healthy. The data confirm the importance of MC3R signaling in human metabolism and suggest a previously unrecognized role for the MC3R in adipose tissue development. Ongoing studies continue to improve our understanding of the phenotype of these mice.

Nicket Dedhia, BA,  
*Postbaccalaureate Intramural  
 Research Training Award Fellow*

Daniel Gehle, BS,  
*Postbaccalaureate Intramural  
 Research Training Award Fellow*

Shannon Marwitz, BS,  
*Postbaccalaureate Intramural  
 Research Training Award Fellow*

Rim D. Mehari, BS,  
*Postbaccalaureate Intramural  
 Research Training Award Fellow*

Katherine Thompson, BA,  
*Postbaccalaureate Intramural  
 Research Training Award Fellow*

We also investigated the BDNF-TrkB pathway in relation to body mass in children. In a cohort of 328 children, aged 3–19 years, we found that obese children had significantly reduced BDNF; BMI, BMI-Z, and body fat were all negatively associated with BDNF. The data suggest that some obese individuals with low serum BDNF for age have mutations that alter BDNF function. We therefore assessed the role of BDNF haplo-insufficiency as a cause of obesity in patients with syndromes attributable to deletions in the vicinity of 11p14.1, where the human *BDNF* gene is located. Of 33 subjects with the WAGR (Wilms tumor, aniridia, genitourinary, and renal abnormalities) syndrome who had heterozygous 11p deletions, ranging in size from 1.0–26.5 Mb, 19 had regions of deletion that involved the *BDNF* gene (*BDNF<sup>+/-</sup>*). Compared with

**FIGURE 1. Energy intake studied by using free-access buffet meals of palatable foods**

Children homozygous for two polymorphisms in the *MC3R* gene (Hom/Hom) consumed more at the buffet than heterozygotes (Het/Het) or those with wild-type *MC3R* (Wt/Wt).

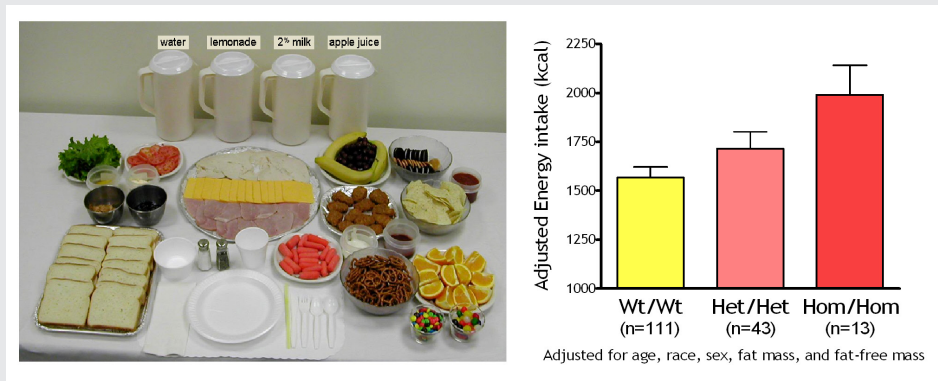

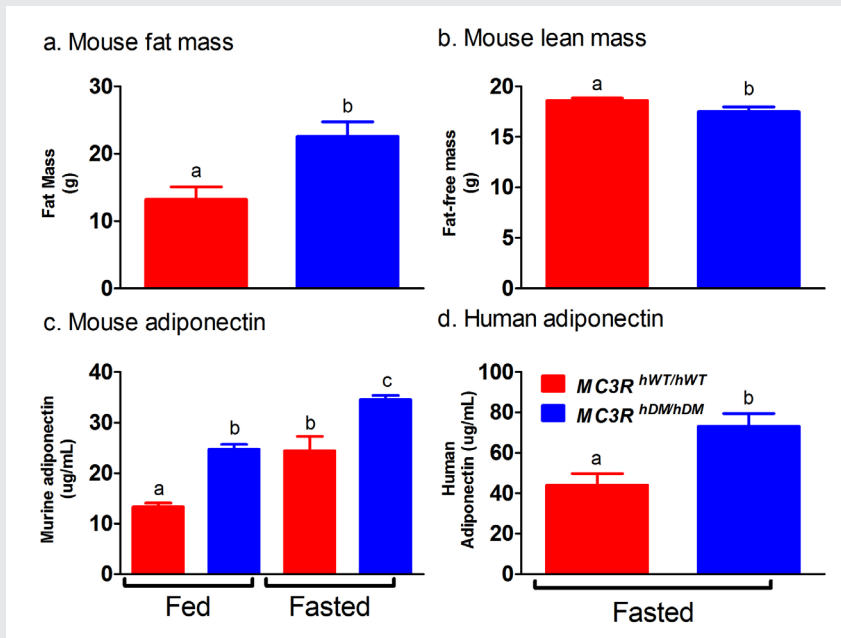

**FIGURE 2. Studies of a human *MC3R* variant containing two naturally occurring polymorphisms**

The variant is associated with pediatric-onset obesity. We found that mice whose *Mc3r* was replaced by human versions of the gene were obese when they expressed the double-mutant gene (*MC3R*<sup>hDM/hDM</sup>)—with greater fat mass (panel a) and lower fat-free mass (panel b), but surprisingly greater adiponectin concentrations (panel c) than mice with the normal human *MC3R* (*MC3R*<sup>hWT/hWT</sup>). Humans with the double-mutant receptor also showed greater adiponectin (panel d).

those with intact BDNF (*BDNF*<sup>+/+</sup>), *BDNF*<sup>+/-</sup> individuals had significantly greater body mass during childhood, starting at age two (Figure 3). A recent investigation examined common polymorphisms in the *BDNF* gene region. We examined human hypothalamic *BDNF* expression in association with 44 *BDNF* single-nucleotide polymorphisms (SNPs). We found that the minor C allele of rs12291063 is associated with significantly lowered human ventro-medial hypothalamic *BDNF* expression and greater adiposity in both adult and pediatric cohorts. We also demonstrated that the major T allele for rs12291063 binds to heterogeneous nuclear ribonucleoprotein D0B, a transcriptional regulator, knockdown of which disrupts transactivation by the T allele (Reference 2). Binding and transactivation functions are both disrupted by substitution of T with the minor C allele. The findings provide a rationale to pursue augmentation of *BDNF* expression and BDNF receptor signaling as targeted obesity treatments for individuals with the rs12291063 CC genotype.

## Physiology, metabolism, and psychology of childhood body weight regulation

Our studies are directed at understanding the physiological, psychological, and metabolic factors that place children at risk for undue weight gain. As part of these studies, we examined how best to measure eating-related psychopathology, insulin sensitivity, changes in body composition, energy intake, and energy expenditure in children and we studied the short- and long-term stability of the components of the metabolic syndrome. We found that leptin is an important predictor of weight gain in children: those with high leptin levels gain more weight than children with normal leptin levels when followed longitudinally. We also documented that hyperinsulinemia is positively related to energy intake in non-diabetic, obese children, leading to treatment studies to reduce hyperinsulinemia (see below). We also examined the relationship between depressive symptomatology and insulin resistance in children and adolescents, finding strong associations both cross-sectionally and prospectively between depressive symptoms and insulin resistance independent of body weight. These associations suggest mechanisms whereby insulin resistance may

**FIGURE 3. WAGR syndrome and deletions of brain-derived neurotrophic factor**

Patients with WAGR syndrome who have haplo-insufficiency for the brain-derived neurotrophic factor gene (*BDNF*) had a higher BMI standard deviation score (BMI z-score) than children and adults with WAGR syndrome who retained two copies of the *BDNF* gene (left panel). Deletions that extended into exon 1 of *BDNF* were associated with 100% risk of childhood-onset obesity (right panel).

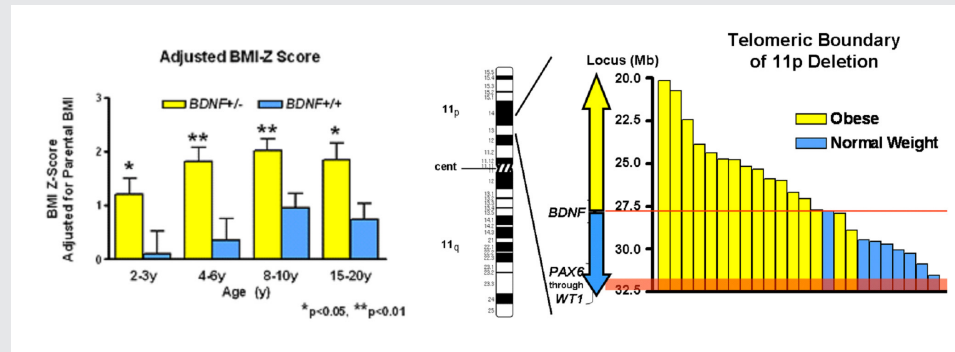

contribute to excessive weight gain in children and have informed some of our treatment approaches to pediatric obesity (described below).

Our evaluations concentrating on binge-eating behaviors in children suggest that such behaviors also are associated with adiposity in children and abnormalities in metabolism. We found that binge-eating behaviors may predict future weight gain in children at risk for obesity. Children reporting binge-eating behaviors such as loss of control (LOC) over eating gained, on average, an additional 2.4 kg of weight per year compared with non-binge-eating children. Our data also suggest that children endorsing binge eating consume more energy during meals. Actual intake during buffet meals averaged 400 kcal more in children with binge eating, but, despite their greater intake, such children reported shorter-lived satiety than children without binge-eating episodes. The ability to consume large quantities of palatable foods, especially when coupled with reduced subsequent satiety, may play a role in the greater weight gain found in binge-eating children. We demonstrated that, among a cohort of 506 lean and obese youth, youth with LOC eating had significantly higher serum leptin than those without LOC episodes, even after adjusting for adiposity and other relevant covariates. The data also suggest that interventions targeting disordered eating behaviors may be useful in preventing excessive fat gain in children prone to obesity and have led to ongoing trials of preventative strategies related to binge eating. Given that binge eating appears to be a heritable trait, we also initiated studies to investigate potential genetic factors linked to LOC eating. For example, we previously reported that, among 229 youth aged 6-19 y who were genotyped for the *FTO* gene SNP rs9939609, subjects with at least one A allele (67.7%) had significantly greater BMI, BMI z-scores, and fat mass. We also found preliminary evidence for link between *FTO* SNP rs9939609 and eating in the absence of hunger.

In order to determine the factors that are most important for development of the complications of obesity in youth, we study normal-weight children and adolescents, children who are already obese, and the non-obese children of obese parents. We examine body composition, leptin concentration, metabolic rate, insulin sensitivity, glucose disposal, energy intake at buffet meals, and genetic factors believed to regulate metabolic rate and body composition. Psychological and behavioral factors, such as propensity to engage in binge-eating behavior (Figure 4), are also studied. We follow children longitudinally into adulthood. In two protocols, we study actual food consumption of children during meals, to elucidate differences in the

### LOC overeating (binge eating) predicts central adiposity and triglycerides > 5y later

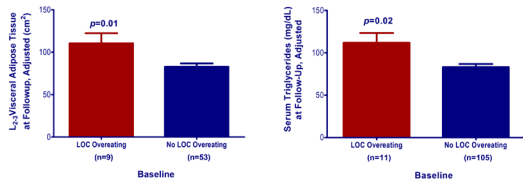

Adjusted for sex; race; baseline age and visceral adipose tissue/triglycerides; time in study

Int J Obes, 2012; 36, 956-62

FIGURE 4. Loss of control (LOC) eating and metabolic complications in a longitudinal study

On average ( $\pm$ SE), children who engaged in binge eating at baseline had more visceral adipose tissue at L<sub>2-3</sub> at follow-up than children who did not engage in binge eating at baseline, adjusting for sex, race, baseline age, baseline visceral adipose tissue at L<sub>2-3</sub>, and time in study ( $P = 0.01$ ). On average ( $\pm$ SE), children who engaged in binge eating at baseline had higher follow-up triglycerides than children who did not engage in binge eating at baseline, adjusting for sex, race, baseline age, body mass index ( $\text{kg}/\text{m}^2$ ), baseline triglycerides, and time in study ( $P = 0.02$ ).

calorie and macro-nutrient content of meals and the circulating hormones related to hunger and satiety in those who either endorse binge-eating behaviors or report no such behaviors. We found that eating in the absence of physiological hunger is a replicable trait that appears linked to obesity. We also investigated the role of sedentary behaviors, such as television watching, as a factor that alters metabolism. In a randomized, controlled, crossover trial (Figure 5), we found that glucose tolerance was markedly improved in children who engaged in moderate activity for just three minutes every half hour, versus remaining sedentary (Reference 3). We hypothesize that differences in these factors predict the development of obesity in the populations studied and may be of great importance in developing rational approaches for the prevention and treatment of obesity in the diverse US population.

## Treatment of obesity and the co-morbid conditions associated with obesity

Given the rapid increase in the prevalence of obesity, the development of treatments for obesity in children and adults is urgently needed, yet current pharmacologic approaches are extremely limited for both children and adults. Thus, in several clinical protocols, we examined approaches for the prevention and treatment of excessive body weight. We completed a pilot study demonstrating that severely obese adolescents can lose weight when enrolled in a comprehensive weight management program that includes the gastrointestinal lipase inhibitor orlistat as an adjunct to a behavioral modification program. We also completed a placebo-controlled randomized trial, studying whether the weight loss of African American and Caucasian children and adolescents who have obesity-related comorbidities was improved by the use of orlistat 120 mg TID. 200 adolescents, 65% female, 61% African American, mean age 14.6 years, BMI  $41.7 \pm 0.6 \text{ kg}/\text{m}^2$  (range 27–87  $\text{kg}/\text{m}^2$ ) were studied, with 85.5% of subjects completing the trial. Adolescents treated with orlistat lost significantly more weight, BMI units, and fat mass than controls. Although pulse and blood pressure fell significantly during the trial, orlistat treatment did not significantly alter these variables. Similarly, HOMA-IR (homeostasis model assessment–insulin resistance), SI (insulin sensitivity index) by FSIGT (frequently sampled intravenous glucose tolerance test), apolipoprotein B, total and LDL-cholesterol, and triglycerides fell significantly in proportion to weight loss, but orlistat use was not associated with significant reductions in any of these obesity-related laboratory comorbidities. Both liver function indicators aspartate aminotransferase (AST) and alanine



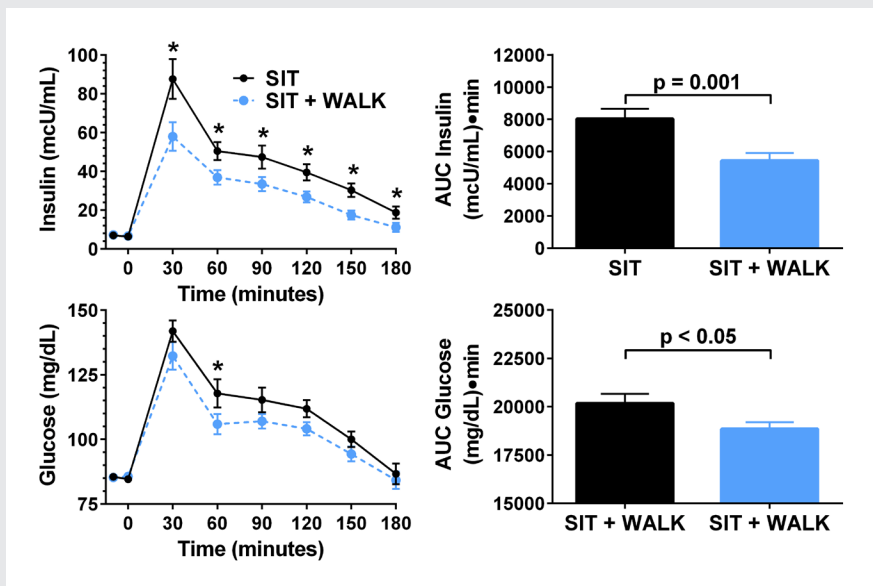

FIGURE 4. Effect of short, moderate intensity walking breaks on children's glucose tolerance

Children who walked for three minutes every 30 minutes (in blue) had lower glucose and insulin concentrations during an oral glucose tolerance test than when they sat uninterrupted for three hours (in black).

aminotransferase (ALT) unexpectedly increased significantly with orlistat treatment. We concluded that orlistat added to a behavioral program significantly improved weight loss over a 6-month interval, but had little impact on obesity-related co-morbid conditions in obese adolescents.

A second obesity treatment study examined the mechanism by which metformin may affect the body weight of younger children who have hyperinsulinemia and are therefore at risk for later development of type 2 diabetes. We conducted a single-center, 6-month, randomized, double-blind, placebo-controlled trial of the effects of metformin, 1000 mg BID administered with meals, in severely obese children (6–12y) who manifested hyperinsulinemia and insulin resistance. 100 obese children (60% female, 11% Hispanic, 3% Asian, 40% African American), mean age  $10.2 \pm 1.5$ y, with mean BMI  $34.6 \pm 6.6$  kg/m<sup>2</sup> (range 23–58 kg/m<sup>2</sup>) were enrolled. 85% of subjects (84% given metformin and 86% given placebo) completed the trial. Compared with placebo-treated children, those randomized to metformin had significantly lower BMI, BMI z-scores, and body fat mass. Serum glucose and HOMA-IR also declined more in metformin-treated than in placebo-treated children. Compared with placebo, metformin treatment also elicited significant reductions from baseline in adjusted mean (+/- standard error) energy intake (metformin:  $-104.7 \pm 83.8$  kcal vs. placebo:  $+144.2 \pm 96.9$  kcal) independently of changes in body composition. Metformin also significantly lowered ratings of hunger and increased ratings of fullness after the pre-meal load (Reference 4). The data suggest that lower perceived hunger resulting in diminished food intake are among the mechanisms by which metformin treatment reduces body weight in overweight children with hyperinsulinemia.

A third clinical trial examined efficacy of two diets among Hispanic children and adolescents, for whom the prevalence of obesity and insulin resistance is considerably greater than in non-Hispanic white children. A low glycemic-load diet (LGD) has been proposed as an effective dietary intervention for pediatric obesity, but no published study had compared the effects of an LGD with those of a low fat diet (LFD) in obese Hispanic children. In the 113 children who were randomly assigned, the glycemic load per kilocalories of reported

food intakes in participants of the LGD group was significantly lower at three months than in the LFD group. However, both groups had a significantly lower BMI z-score, which was expressed as a standard z-score relative to CDC age- and sex-specific norms, and significantly improved waist circumference and systolic blood pressure at 3, 12, and 24 months after intervention. We found no evidence that an LGD and an LFD differ in efficacy for the reduction of BMI or aspects of metabolic syndrome in obese Hispanic youth. Both diets lowered the BMI z-score when prescribed in the context of a culturally adapted, comprehensive weight-reduction program.

A fourth completed study examined prevention of weight gain using interpersonal therapy in adolescents reporting LOC eating behaviors (Reference 5). An additional study tested methods to reduce insulin resistance in adolescents at risk for type 2 diabetes. We also participated in a multi-site randomized-controlled trial of beloranib, a methionyl aminopeptidase 2 inhibitor, to treat the hyperphagia of patients with the Prader Willi syndrome. In the near future, we expect to initiate additional translational trials related to modulation of the leptin signaling pathway. Also, a novel intervention, a trial that is actively enrolling, is a randomized-controlled study of colchicine to ameliorate the inflammation that accompanies obesity and thus improve its complications.

## Additional Funding

- NIH Clinical Center “Bench to Bedside” Award: Attention Bias Retraining in Adolescents with Loss of Control Eating. ORWH 2016–2017
- Office of Disease Prevention, NIH: Grant supplement to support the clinical protocol “Effects of Interrupting Sedentary Behavior on Metabolic and Cognitive Outcomes in Children.” 2016–2017
- NICHD Director's Award: “Suppression of NLRP3 Inflammasome Activation with Colchicine to Ameliorate Obesity-Associated Metabolic Abnormalities.” 2014–2016
- Zafgen Inc: “Randomized, Double-Blind, Placebo Controlled, Phase 3 Trial of ZGN-440 (Subcutaneous Beloranib in Suspension, Zafgen, Inc.) in Obese Subjects with Prader-Willi Syndrome to Evaluate Total Body Weight, Food-Related Behavior, and Safety over 6 Months.” Funds an RCT testing a new methionine aminopeptidase inhibitor in patients with Prader-Willi syndrome and obesity. 2014–2016

## Publications

1. Lee B, Koo J, Yun Jun J, Gavrilova O, Lee Y, Seo AY, Taylor-Douglas DC, Adler-Wailes DC, Chen F, Gardner R, Koutzoumis D, Sherafat Kazemzadeh R, Roberson RB, Yanovski JA. A mouse model for a partially inactive obesity-associated human MC3R variant. *Nat Commun* 2016 7:10522.
2. Mou Z, Hyde TM, Lipska BK, Martinowich K, Wei P, Ong C, Hunter LA, Palaguachi GI, Morgun E, Teng R, Lai CF, Condarco TA, Demidowich AP, Krause AJ, Marshall LJ, Haack K, Voguganti S, Cole SA, Butte NF, Comuzzie AG, Nalls MA, Zonderman AB, Singleton AB, Evans MK, Martin B, Maudsley S, Tsao JW, Kleinman JE, Yanovski JA, Han JC. Human obesity associated with an intronic SNP in the brain-derived neurotrophic factor locus. *Cell Rep* 2015 13:1073-1080.
3. Belcher BR, Berrigan D, Papachristopoulou A, Brady SM, Bernstein SB, Brychta RJ, Hattenbach JD, Tigner IL, Courville AB, Drinkard BE, Smith KP, Rosing DR, Wolters PL, Chen KY, Yanovski JA. Effects of interrupting children's sedentary behaviors with activity on metabolic function: a randomized trial. *J Clin Endocrinol Metab* 2015 100:3735-3743.

4. Adeyemo MA, McDuffie JR, Kozlosky M, Krakoff J, Calis KA, Brady SM, Yanovski JA. Effects of metformin on energy intake and satiety in obese children. *Diabetes Obes Metab* 2015 17:363-370.
5. Tanofsky-Kraff M, Crosby RD, Vannucci A, Kozlosky M, Shomaker LB, Brady SM, Sbrocco T, Pickworth CK, Stephens M, Young JF, Olsen C, Kelly NR, Radin R, Cassidy O, Wilfley DE, Reynolds JC, Yanovski JA. Effect of adapted interpersonal psychotherapy versus health education on mood and eating in the laboratory among adolescent girls with loss of control eating. *Int J Eat Disord* 2016 49:490-498.

## Collaborators

- Silva Arslanian, MD, *Children's Hospital of Pittsburgh, Pittsburgh, PA*
- Jeffrey Baron, MD, *Section on Growth and Development, NICHD, Bethesda, MD*
- Andrew Butler, PhD, *The Scripps Research Institute, La Jolla, CA*
- Nancy Butte, PhD, *Baylor College of Medicine, Houston, TX*
- Kong Chen, PhD, *Clinical Endocrinology Branch, NIDDK, Bethesda, MD*
- Anthony Comuzzie, PhD, *Southwest National Primate Research Center, San Antonio, Texas*
- I. Sadaf Farooqi, MD, *Cambridge Institute for Medical Research, Cambridge, UK*
- Oksana Gavrilova, PhD, *Mouse Metabolism Core Laboratory, NIDDK, Bethesda, MD*
- Joan C. Han, MD, *Le Bonheur Children's Hospital, Memphis, TN*
- Steven B. Heymsfield, MD, *Pennington Biomedical Research Center, Baton Rouge, LA*
- Michael Jensen, MD, *Mayo Clinic, Rochester, MN*
- Rudolph L. Leibel, MD, *Columbia University College of Physicians and Surgeons, New York, NY*
- Sergey Leikin, PhD, *Section on Physical Biochemistry, NICHD, Bethesda, MD*
- David S. Ludwig, MD, PhD, *Children's Hospital, Boston, Boston MA*
- Cara Olsen, PhD, *Uniformed Services University of the Health Sciences, Bethesda, MD*
- Stephen O'Rahilly, MD, *Cambridge Institute for Medical Research, Cambridge, UK*
- Daniel Pine, MD, *Section on Development and Affective Neuroscience, NIMH, Bethesda, MD*
- Lauren B. Shomaker, PhD, *University of Colorado, Boulder, CO*
- Eric Stice, PhD, *Oregon Research Institute, Eugene, OR*
- Marian Tanofsky-Kraff, PhD, *Uniformed Services University of the Health Sciences, Bethesda, MD*
- B. Timothy Walsh, PhD, *Columbia University College of Physicians and Surgeons, New York, NY*
- Denise E. Wilfley, PhD, *Washington University School of Medicine, St. Louis, MO*
- Joshua Zimmerberg, MD, PhD, *Section on Cellular and Membrane Biophysics, NICHD, Bethesda, MD*

## Contact

For more information, email [jy15i@nih.gov](mailto:jy15i@nih.gov) or visit <http://sgo.nichd.nih.gov>.

## The Regulation or Disturbance of Protein/Lipid Interactions in Influenza, Malaria, Diabetes, Muscular Dystrophy, Brain Trauma, and Obesity

Eukaryotic life must create the many shapes and sizes of the system of internal membranes and organelles that inhabit the variety of cells in nature. The membranes must remodel so that cells can secrete signaling macromolecules, express surface transporters, import macromolecular cargo, store energy, repair a damaged plasmalemma, and deal with infectious agents such as viruses and parasites. Such basic membrane mechanisms must be highly regulated and highly organized in various hierarchies in space and time to allow the organism to thrive despite environmental challenges, genetic instability, an unpredictable food supply, and physical trauma. We are using our expertise and techniques that we have perfected over the years to address several different biological problems that nevertheless share the underlying regulation or disturbance of protein/lipid interactions. Our overall goal is to determine the physico-chemical mechanisms of membrane remodeling in cells and to understand the mechanisms of cellular secretion and endocytosis at physical, biophysical, and chemical levels, including the concentration and diffusion of key vesicular components prior to and after fusion or fission.

This past year, we focused on four topics: (1) elucidation of the intermediates of membrane fusion using Volta phase plate cryoelectron tomography, and the effects of cholesterol on these intermediates; (2) elucidation of the cell type that responds to the fundamental forces that emerge upon blast-like stimuli; (3) development of a new tool (resin-embedded multicycle imaging, REMI) for determining co-localized proteins using cycles of immune-staining, imaging, and stripping of the antibodies; and (4) determination of the calcium content of the endoplasmic reticulum, the first compartment that secreted proteins occupy in the secretory pathway.

### Cryo-electron microscope tomography using a novel phase plate reveals intermediates of the influenza infection

The virus that causes influenza is coated with spike proteins known as hemagglutinin (HA), which play a major role in determining its immunogenicity and thus the vaccine to influenza. The HA



**Joshua Zimmerberg, MD, PhD,**  
*Head, Section on Cellular and Membrane Biophysics*

Paul S. Blank, PhD, *Staff Scientist*

Svetlana Glushakova, MD, PhD,  
*Staff Scientist*

Vladimir A. Lizunov, MS, *Research Fellow*

Petr Chlanda, PhD, *Visiting Fellow*

Matthias Garten, PhD, *Visiting Fellow*

Sourav Haldar, PhD, *Visiting Fellow*

Brad Busse, PhD, *Postdoctoral Intramural Research Training Award Fellow*

Chad McCormick, PhD,  
*Postdoctoral Intramural Research Training Award Fellow*

Ludmila Bezrukov, MS, *Chemist*

Hang Waters, MS, *Biologist*

Michael J. Curran, PhD, *Contractor*

Jane E. Farrington, MS, *Contractor*

Elena Mekhedov, MA, *Contractor*

Tatyana I. Tenkova-Heuser, PhD,  
*Contractor*

Glen Humphrey, PhD, *Guest Researcher*

**HA spikes in close proximity to lipidic junctions and ruptured membranes.**

a,c, Tomogram slices (3 nm thick), calculated by the weighted back projection method, from a tilt series acquired at a defocus of  $-1\ \mu\text{m}$  with VPP and after NAD and Gaussian filtering, capturing a liposome containing 16 mol% cholesterol in proximity to G1S VLPs at low pH. In the left panel of a and in c, the ruptured liposome membrane is in close proximity to glycoproteins. In the central and right panels of a, the lipidic junction of the membrane sheet is inserted into the VLP membrane (red arrowhead in the magnified view below) and glycoproteins are shown inside the HD (right panel). Bottom (a,c): corresponding magnified views. Red arrows mark glycoproteins in the proximity of HD or the

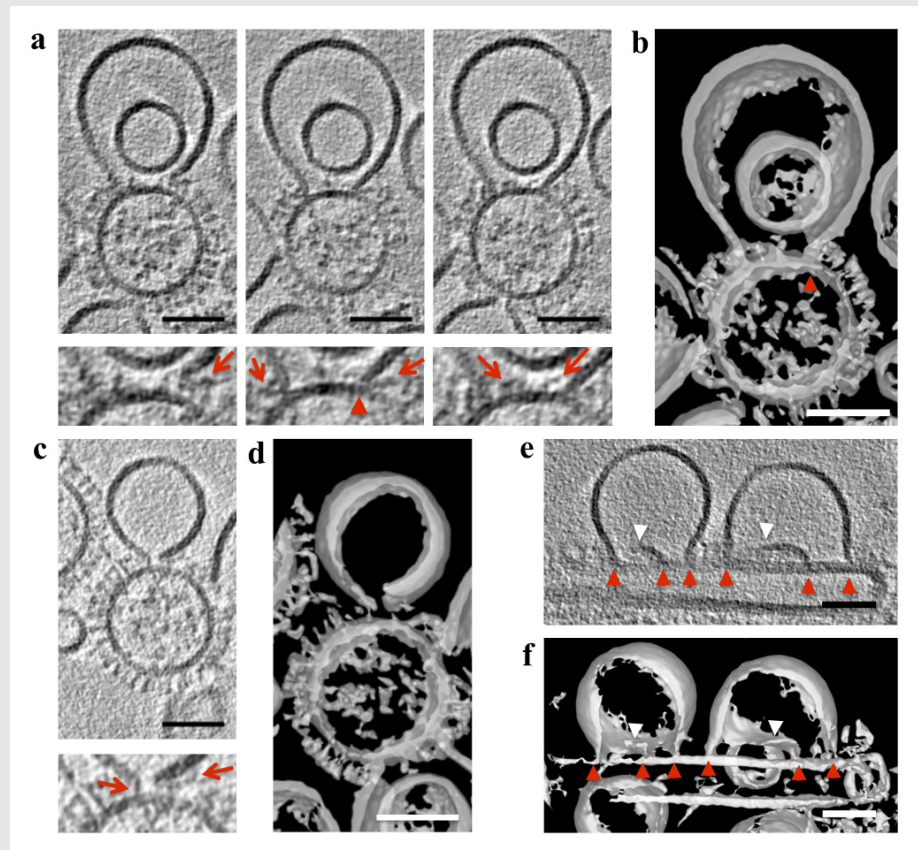

open liposomal membrane. b,d, Isosurfaces of the NAD-filtered tomographic volume calculated by the weighted simultaneous iterative reconstruction technique shown in a and c, respectively, also show material within the lipidic junctions and a lack of HD completion. e, A tomogram slice (3 nm thick), calculated by the weighted back-projection method, from a tilt series acquired at a defocus of  $-1\ \mu\text{m}$  with VPP showing fusion intermediates between liposomes and filamentous G1S VLPs. Red arrowheads indicate lipidic junctions and white arrowheads indicate free membrane edges. f, Isosurface of the NAD-filtered tomographic volume calculated by the weighted simultaneous iterative reconstruction technique shown in e, further illustrating the lipidic junctions and free membrane edges. Scale bars, 50 nm. The tomographic slices are representative of 40 and 16 VLP-liposome interactions found in 12 and 10 tomograms collected with and without VPP on two independent grids of two independent samples, respectively.

protein plays a crucial role during infection after viral endocytosis, undergoing a conformational change that drives membrane fusion of the viral and endosomal membranes at the low pH of the endosome. Although membrane fusion is widely thought to proceed through an intermediate called hemifusion, the hemifusion structure had never been determined. In this project, we studied influenza virus-like particles carrying wild-type HA or an HA hemifusion mutant (G1S) and liposome mixtures at low pH using cryo-electron tomography. For the first time in virology, the Volta phase plate was used, a phase plate that improves the signal-to-noise ratio close to focus. We determined two distinct hemifusion structures: a hemifusion diaphragm and a novel structure termed a lipidic junction. Liposomes with lipidic junctions were ruptured with membrane edges stabilized by HA. The rupture frequency and hemifusion diaphragm diameter were not affected by the G1S mutation, but declined when the cholesterol level in the liposomes

was close to physiological concentrations. We propose that HA induces a merger between the viral and target membranes by one of two independent pathways: a rupture-insertion pathway leading to the lipidic junction or a hemifusion-stalk pathway leading to a fusion pore. The latter is relevant under the conditions of influenza virus infection of cells. The cholesterol concentration functions as a pathway switch because of cholesterol's negative spontaneous curvature in the target bilayer, as determined by continuum analysis.

## Blast-induced traumatic brain injury results from shear forces acting on astrocytes.

Blast-induced traumatic brain injury (bTBI) continues to be a worldwide health problem. bTBI can be complex, resulting from one or more physical phases of the blast phenomenon. Even those experiencing low-level blast explosions, such as those produced by explosives used to breach fortifications, can develop neurocognitive symptoms without evidence of neurotrauma. The cellular mechanisms of the phenomenon are unknown. The primary phase of bTBI, characterized by organ-shockwave interaction, is unique to blast exposure. Understanding the mechanisms and pathology arising from the primary phase of bTBI is limited, in part because of the limited availability of *in vitro* models simulating the blast shockwave. It is therefore critical to develop experimental methods to study the primary phase of bTBI. To better study this phase, we developed a pneumatic device that simulates an explosive blast by producing pressure transients similar to those observed in a free-field explosion and which is compatible with real-time fluorescence microscopy of cultured cells; the device can produce blast-like pressure transients with and without accompanying shear forces. Using  $\text{Ca}^{2+}$  ion-selective fluorescent indicators, we could detect changes in intracellular free calcium following simulated blast. We previously showed that: (1) cultured human brain cells are indifferent to transient shockwave pressures known to cause mild bTBI; (2) when sufficient shear forces are simultaneously induced with the shockwave pressure, central nervous system (CNS) cells respond with increased intracellular  $\text{Ca}^{2+}$  that propagates from cell to cell; and (3) cell survival is unaffected 20 hours after shockwave exposure. We determined the cell type responsible for the waves of increased intracellular free  $\text{Ca}^{2+}$  in dissociated human CNS cultures, and we found that the calcium waves primarily propagate through astrocyte-dependent, purinergic signaling pathways that are blocked by P2 receptor antagonists. Human astrocytes exhibited a greater increase in calcium response than did rat astrocytes and longer calcium wave propagation kinetics, suggesting that, in our model system, rat CNS cells are less responsive to a simulated blast. Furthermore, in response to a simulated blast, expression of a reactive astrocyte marker, glial fibrillary acidic protein (GFAP), and a protease, matrix metalloproteinase 9 (MMP-9) in human CNS cells increases. The conjoint increased expression of GFAP and MMP-9 and the reduction in calcium response after application of a purinergic ATP (P2) receptor antagonist identify both potential mechanisms for sustained changes in brain function following primary bTBI and therapeutic strategies targeting abnormal astrocyte activity.

## REMI: a new cell and membrane histochemical proteomic method for molecular anatomy

Protein complexes associated with cellular processes comprise a significant fraction of all biology, but our understanding of their heterogeneous organization remains inadequate, particularly for physiological densities of multiple protein species. Recent advances in microscopy allow us to localize within cells both individual proteins and some of the interactions between proteins predicted by immunoprecipitation and genetic complementation, but the sheer number of protein species involved in any one biological structure is becoming an ever more limiting factor. Many-color immuno-histochemistry, while flexible and selective, requires primary antibodies that are either directly coupled to fluorophores or from many diverse species,

often forcing a shift to suboptimally affine primary antibodies. Although available immuno-histochemical labels can be supplemented with expressed markers and other methods, their potential permutations still present an overwhelming hurdle for current microscopy methods. Alternatives, such as the expression of tags for subsequent labeling, positively impact the rate at which different molecules can be imaged, but protein colocalization remains speculative with these techniques. Additionally, techniques exist to permit antibody reuse in unembedded tissue with a variety of elution methods, but the precision of subsequent labeling and tissue damage have not been documented.

Towards resolving this limitation, this year we reported a new technique based on resin-embedded multicycle imaging (REMI) of proteins *in situ*. By stabilizing protein structure and antigenicity in acrylic resins, affinity labels can be repeatedly applied, imaged, removed, and replaced. In principle, an arbitrarily large number of proteins of interest may be imaged on the same specimen with subsequent digital overlay. A series of novel preparative methods were developed to address the problem of imaging several protein species in areas of the plasma membrane or volumes of the cytoplasm of individual cells. For multiplexed examination of antibody staining, we used straightforward computational techniques to align sequential images and super-resolution microscopy to further define membrane protein colocalization. In one example of a fibroblast membrane with eight multiplexed proteins, a simple statistical analysis of this limited membrane proteomic dataset is sufficient to demonstrate the analytical power contributed by additional imaged proteins when studying membrane-protein domains.

## Detecting intracellular calcium stores within the endoplasmic reticulum in cell models of osteogenesis imperfecta

Recessive osteogenesis imperfecta (OI) is caused by defects in proteins involved in post-translational interactions with type I collagen. Recently, a novel form of moderately severe OI caused by null mutations in TMEM38B was identified. TMEM38B encodes the endoplasmic reticulum (ER) membrane monovalent cation channel TRIC-B, which is thought to counterbalance inositol trisphosphate receptor (IP3R)-mediated  $\text{Ca}^{2+}$  release from intracellular stores. The molecular mechanisms by which TMEM38B mutations cause OI are unknown. We identified three probands with recessive defects in TMEM38B. TRIC-B protein is undetectable in proband fibroblasts and osteoblasts, although reduced TMEM38B transcripts are present. TRIC-B deficiency causes impaired release of ER-luminal  $\text{Ca}^{2+}$ , associated with deficient store-operated calcium entry, although sarco/endoplasmic reticulum  $\text{Ca}^{2+}$ -ATPase (SERCA) and IP3R have normal stability. To determine whether the lower  $\text{Ca}^{2+}$  flux in TRIC-B-deficient cells was associated with abnormal  $\text{Ca}^{2+}$  steady-state levels within the ER, we measured free ER  $\text{Ca}^{2+}$  using the targeted ratiometric calcium sensor D1ER. Interestingly, there was no measurable change in ER-luminal free  $\text{Ca}^{2+}$  in proband or normal control cells following ATP treatment, suggesting that the amount of stored  $\text{Ca}^{2+}$  required to elevate cytoplasmic  $\text{Ca}^{2+}$  is minor compared with total  $\text{Ca}^{2+}$  available in the ER. Furthermore, we observed no significant differences in the baseline (before ATP treatment) and depleted (after ionomycin treatment) ER  $\text{Ca}^{2+}$  signals between normal control and proband cells. This indicates that TRIC-B deficiency does not result in altered steady-state luminal ER free  $\text{Ca}^{2+}$  as, for example, a result of the abnormal  $\text{Ca}^{2+}$  flux. Luminal ER free  $\text{Ca}^{2+}$  is neither decreased nor increased.

The disturbed  $\text{Ca}^{2+}$  flux causes ER stress and increased BiP (binding immunoglobulin protein, involved in ER stress), and dysregulates synthesis of proband type I collagen at several steps. Collagen helical lysine hydroxylation is reduced, while telopeptide hydroxylation is increased, despite increased lysyl hydroxylase 1

(LH1) and decreased Ca<sup>2+</sup>-dependent FKBP65 (required for lysyl hydroxylase activity/access to type I collagen telopeptide lysines), respectively. Although the levels of the ER-resident protein disulfide isomerase PDI, a component of prolyl-4-hydroxylase, which is involved in collagen formation) are maintained, procollagen chain assembly is delayed in proband cells. The resulting misfolded collagen is substantially retained in TRIC-B null cells, consistent with a 50–70% reduction in secreted collagen. Lower-stability forms of collagen that elude proteasomal degradation are not incorporated into extracellular matrix, which contains only collagen with normal stability, resulting in matrix insufficiency. These data support a role for TRIC-B in intracellular Ca<sup>2+</sup> homeostasis and demonstrate that absence of TMEM38B causes OI by dysregulation of calcium flux kinetics in the ER, impacting several collagen-specific chaperones and collagen-modifying enzymes.

## Additional Funding

- Jain Foundation Award
- NICHD Director's Award (Co-Principal Investigator with Jack Yanovski)

## Publications

1. Chlanda P, Mekhedov E, Waters H, Schwartz CL, Fischer ER, Ryham RJ, Cohen FS, Blank PS, Zimmerberg J. The hemifusion structure induced by influenza virus haemagglutinin is determined by physical properties of the target membranes. *Nat Microbiol* 2016 1:16050.
2. Lizunov VA, Stenkula KG, Blank PS, Troy A, Lee J-P, Skarulis MC, Cushman SW, Zimmerberg J. Human adipose cells in vitro are either refractory or responsive to insulin, reflecting host metabolic state. *PLoS One* 2015 10:e0119291.
3. Ravin R, Blank PS, Busse B, Ravin N, Vira S, Bezrukov L, Waters H, Guerrero-Cazares H, Quinones-Hinojosa A, Lee PR, Fields RD, Bezrukov SM, Zimmerberg J. Blast shockwaves propagate Ca(2+) activity via purinergic astrocyte networks in human central nervous system cells. *Sci Rep* 2016 6:25713.
4. Cabral WA, Ishikawa M, Garten M, Makareeva EN, Sargent BM, Weis M, Barnes AM, Webb EA, Shaw NJ, Ala-Kokko L, Lacbawan FL, Högl W, Leikin S, Blank PS, Zimmerberg J, Eyre DR, Yamada Y, Marini JC. Absence of the ER cation channel TMEM38B/TRIC-B disrupts intracellular calcium homeostasis and dysregulates collagen synthesis in recessive osteogenesis imperfecta. *PLoS Genet* 2016 12:e1006156.
5. Busse BL, Bezrukov L, Blank PS, Zimmerberg J. Resin embedded multicycle imaging (REMI): a tool to evaluate protein domains. *Sci Rep* 2016 6:30284.

## Collaborators

- Oleg Batishchev, PhD, A.N. Frumkin Institute of Physical Chemistry and Electrochemistry, Russian Academy of Sciences, Moscow, Russia
- Wayne A. Cabral, PhD, Bone and Extracellular Matrix Branch, NICHD, Bethesda, MD
- Fredrick S. Cohen, PhD, Rush University, Chicago, IL
- Nikki Curthoys, PhD, University of Maine, Orono, ME
- Rick M. Fairhurst, MD, PhD, Laboratory of Malaria and Vector Research, NIAID, Bethesda, MD
- Vadim Frolov, PhD, Universidad del País Vasco, Bilbao, Spain
- Hugo Guerrero-Cazares, MD, The Johns Hopkins University, Baltimore, MD
- Samuel T. Hess, PhD, University of Maine, Orono, ME



- Mary Kraft, PhD, *University of Illinois at Urbana-Champaign, Urbana, IL*
- Joan Marini, MD, PhD, *Section on Heritable Disorders of Bone and Extracellular Matrix, NICHD, Bethesda, MD*
- Jeffery Miller, MD, *Molecular Medicine Branch, NIDDK, Bethesda, MD*
- Alfredo Quinones-Hinojosa, MD, *The Johns Hopkins University, Baltimore, MD*
- Thomas S. Reese, MD, *Laboratory of Neurobiology, NINDS, Bethesda, MD*
- Rolf J. Ryham, PhD, *Fordham University, Bronx, NY*
- Anna Shnyrova, PhD, *Universidad del País Vasco, Bilbao, Spain*
- Peter K. Weber, PhD, *Lawrence Livermore National Laboratory, Livermore, CA*

## Contact

For more information, email [zimmerbj@mail.nih.gov](mailto:zimmerbj@mail.nih.gov) or visit <https://irp.nih.gov/pi/joshua-zimmerberg>.

# Colophon

---

## About the Cover Image

Created by Xiaozhuo “Dalton” Liu and Owen Rennert, in collaboration with the Hoffman Lab.

Immunofluorescence image of autistic patient-specific iPSC-derived neuronal progenitor cells with neural rosette structures as visualized by using PAX6 (Red), NESTIN (Green) and DAPI (Blue) staining.

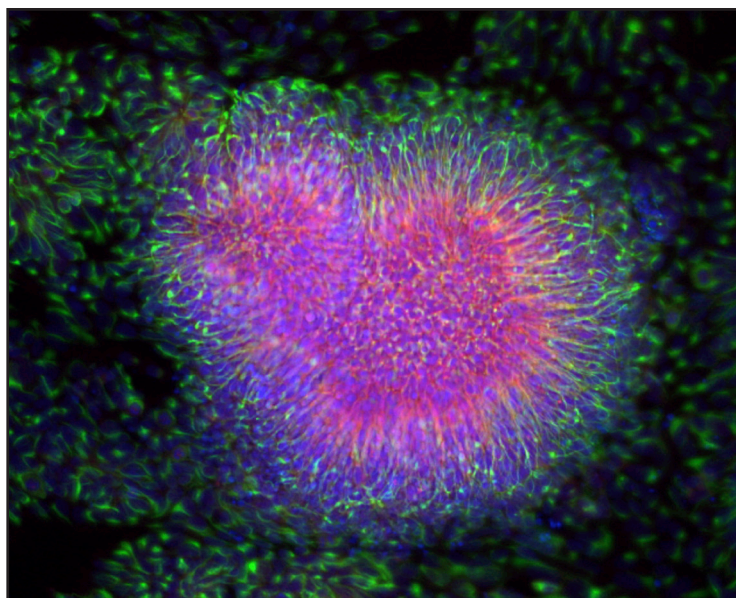

## Production Credits

Managing and Scientific Editor: Birgit An der Lan, Ph.D.

Design and Layout: Nichole Swan

Application Development: Loc Vu

Head, Computer Support Services Core: Dave Songco

## For further information, contact:

Constantine A. Stratakis, M.D., D(med)Sci, Scientific Director

*Eunice Kennedy Shriver* National Institute of Child Health and Human Development

Building 31, Room 2A46

31 Center Drive MSC 2425

Bethesda, MD 20892-2425

Phone: 301-594-5984

Email: [NICHDsd@mail.nih.gov](mailto:NICHDsd@mail.nih.gov)

Fax: 301-402-0105

Website: <http://dir.nichd.nih.gov>

U.S. Department of Health and Human Services

Public Health Service

National Institutes of Health

An online version of this report can be found at <http://annualreport.nichd.nih.gov>.